

UTMS 2011–5

February 24, 2011

**Fractional calculus of Weyl algebra  
and Fuchsian differential equations**

by

Toshio OSHIMA

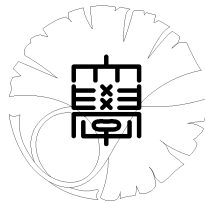

**UNIVERSITY OF TOKYO**

GRADUATE SCHOOL OF MATHEMATICAL SCIENCES

KOMABA, TOKYO, JAPAN

# FRACTIONAL CALCULUS OF WEYL ALGEBRA AND FUCHSIAN DIFFERENTIAL EQUATIONS

TOSHIO OSHIMA

ABSTRACT. We give a unified interpretation of confluences, contiguity relations and Katz's middle convolutions for linear ordinary differential equations with polynomial coefficients and their generalization to partial differential equations. The integral representations and series expansions of their solutions are also within our interpretation. As an application to Fuchsian differential equations on the Riemann sphere, we construct a universal model of Fuchsian differential equations with a given spectral type, in particular, we construct single ordinary differential equations without apparent singularities corresponding to the rigid local systems, whose existence was an open problem presented by Katz. Furthermore we obtain an explicit solution to the connection problem for the rigid Fuchsian differential equations and the necessary and sufficient condition for their irreducibility. We give many examples calculated by our fractional calculus.

## CONTENTS

1. Introduction	2
2. Fractional operations	12
2.1. Weyl algebra	12
2.2. Laplace and gauge transformations and reduced representatives	13
2.3. Examples of ordinary differential operators	15
2.4. Ordinary differential equations	20
2.5. Okubo normal form and Schlesinger canonical form	21
3. Confluences	23
3.1. Regular singularities	23
3.2. A confluence	28
3.3. Versal additions	28
3.4. Versal operators	30
4. Series expansion	32
5. Contiguity relation	35
6. Fuchsian differential equation and generalized Riemann scheme	36
6.1. Generalized characteristic exponents	36
6.2. Tuples of partitions	40
6.3. Conjugacy classes of matrices	42
6.4. Realizable tuples of partitions	43
7. Reduction of Fuchsian differential equations	47
8. Deligne-Simpson problem	57
8.1. Fundamental lemmas	57
8.2. Existence theorem	59
8.3. Divisible spectral types	64

---

*Key words and phrases.* Fuchsian systems, middle convolution, hypergeometric functions, special functions, Weyl algebra.

*2000 Mathematics Subject Classification.* Primary 34M35; Secondary 34M40, 34M15

Supported by Grant-in-Aid for Scientific Researches (A), No. 20244008, Japan Society of Promotion of Science.

8.4. Universal model	66
8.5. Simply reducible spectral type	68
9. A Kac-Moody root system	71
9.1. Correspondence with a Kac-Moody root system	71
9.2. Fundamental tuples	80
10. Expression of local solutions	82
11. Monodromy	86
11.1. Middle convolution of monodromies	86
11.2. Scott's lemma and Katz's rigidity	92
12. Reducibility	95
12.1. Direct decompositions	95
12.2. Reduction of reducibility	100
13. Shift operators	107
13.1. Construction of shift operators and recurrence relations	108
13.2. Relation to reducibility	112
13.3. Polynomial solutions	115
14. Connection problem	116
14.1. Connection formula	116
14.2. An estimate for large exponents	122
14.3. Zeros and poles of connection coefficients	126
15. Examples	134
15.1. Basic tuples	135
15.2. Rigid tuples	138
15.3. Jordan-Pochhammer family	141
15.4. Hypergeometric family	145
15.5. Even/Odd family	150
15.6. Trigonometric identities	156
15.7. Rigid examples of order at most 4	157
15.8. Other rigid examples with a small order	162
15.9. Submaximal series and minimal series	167
15.10. Appell's hypergeometric functions	179
15.11. Okubo and Risa/Asir	185
16. Further problems	186
16.1. Multiplicities of spectral parameters	186
16.2. Schlesinger canonical form	186
16.3. Apparent singularities	186
16.4. Irregular singularities	186
16.5. Special parameters	187
16.6. Shift operators	188
16.7. Several variables	188
16.8. Other problems	188
17. Appendix	189
References	190
Index	192

## 1. INTRODUCTION

Gauss hypergeometric functions and the functions in their family, such as Bessel functions, Whittaker functions, Hermite functions, Legendre polynomials and Jacobi polynomials etc. are the most fundamental and important special functions (cf. [EMO, Wa, WW]). Many formulas related to the family have been studied and

clarified together with the theory of ordinary differential equations, the theory of holomorphic functions and relations with other fields. They have been extensively used in various fields of mathematics, mathematical physics and engineering.

Euler studied the hypergeometric equation

$$(1.1) \quad x(1-x)y'' + (c - (a+b+1)x)y' - aby = 0$$

with constant complex numbers  $a$ ,  $b$  and  $c$  and he got the solution

$$(1.2) \quad F(a, b, c; x) := \sum_{k=0}^{\infty} \frac{a(a+1) \cdots (a+k-1) \cdot b(b+1) \cdots (b+k-1)}{c(c+1) \cdots (c+k-1) \cdot k!} x^k.$$

The series  $F(a, b, c; x)$  is now called Gauss hypergeometric series or function and Gauss proved the Gauss summation formula

$$(1.3) \quad F(a, b, c; 1) = \frac{\Gamma(c)\Gamma(c-a-b)}{\Gamma(c-a)\Gamma(c-b)}$$

when the real part of  $c$  is sufficiently large. Then in the study of this function an important concept was introduced by Riemann. That is the Riemann scheme

$$(1.4) \quad \left\{ \begin{array}{ccc} x=0 & 1 & \infty \\ 0 & 0 & a \\ 1-c & c-a-b & b \end{array} ; x \right\}$$

which describes the property of singularities of the function and Riemann proved that this property characterizes the Gauss hypergeometric function.

The equation (1.1) is a second order Fuchsian differential equation on the Riemann sphere with the three singular points  $\{0, 1, \infty\}$ . One of the main purpose of this paper is to generalize these results to the general Fuchsian differential equation on the Riemann sphere. In fact our study will be applied to the following three kinds of generalizations.

One of the generalizations of the Gauss hypergeometric family is the hypergeometric family containing the generalized hypergeometric function  ${}_nF_{n-1}(\alpha, \beta; x)$  or the solutions of Jordan-Pochhammer equations. Some of their global structures are concretely described as in the case of the Gauss hypergeometric family.

The second generalization is a class of Fuchsian differential equations such as the Heun equation which is of order 2 and has 4 singular points in the Riemann sphere. In this case there appear *accessory parameters*. The global structure of the generic solution is quite transcendental and the Painlevé equation which describes the deformations preserving the monodromies of solutions of the equations with an apparent singular point is interesting and has been quite deeply studied and now it becomes an important field of mathematics.

The third generalization is a class of hypergeometric functions of several variables, such as Appell's hypergeometric functions (cf. [AK]), Gelfand's generalized hypergeometric functions (cf. [Ge]) and Heckman-Opdam's hypergeometric functions (cf. [HO]). The author and Shimeno [OS] studied the ordinary differential equations satisfied by the restrictions of Heckman-Opdam's hypergeometric function on singular lines through the origin and we found that some of the equations belong to the even family classified by Simpson [Si], which is now called a class of *rigid* differential equations and belongs to the first generalization in the above.

The author's original motivation related to the study in this note is a generalization of Gauss summation formula, namely, to calculate a connection coefficient for a solution of this even family, which is solved in §14 as a direct consequence of the general formula (1.21) of certain connection coefficients described in Theorem 14.6. This paper is the author's first step to a unifying approach for these generalizations

and the recent development in general Fuchsian differential equations described below with the aim of getting concrete and computable results. In this paper we will avoid intrinsic arguments and results if possible and hence the most results can be implemented in computer programs. Moreover the arguments in this paper will be understood without referring to other papers.

Rigid differential equations are the differential equations which are uniquely determined by the data describing the local structure of their solutions at the singular points. From the point of view of the monodromy of the solutions, the rigid systems are the local systems which are uniquely determined by local monodromies around the singular points and Katz [Kz] studied rigid local systems by defining and using the operations called *middle convolutions* and *additions*, which enables us to construct and analyze all the rigid local systems. In fact, he proved that any irreducible rigid local system is transformed into a trivial equation  $\frac{du}{dz} = 0$  by successive application of the operations. In another word, any irreducible rigid local system is obtained by successive applications of the operations to the trivial equation because the operations are invertible.

The arguments there are rather intrinsic by using perverse sheaves. Dettweiler-Reiter [DR, DR2] interprets Katz's operations on monodromy generators and those on the systems of Fuchsian differential equations of Schlesinger canonical form

$$(1.5) \quad \frac{du}{dx} = \sum_{j=1}^p \frac{A_j}{x - c_j} u$$

with constant square matrices  $A_1, \dots, A_p$ .

Here  $A_j$  are called the residue matrices of the system at the singular points  $x = c_j$ , which describe the local structure of the solutions. For example, the eigenvalues of the monodromy generator at  $x = c_j$  are  $e^{2\pi\sqrt{-1}\lambda_1}, \dots, e^{2\pi\sqrt{-1}\lambda_n}$ , where  $\lambda_1, \dots, \lambda_n$  are eigenvalues of  $A_j$ . The residue matrix of the system at  $x = \infty$  equals  $A_0 := -(A_1 + \dots + A_p)$ . These operations are useful also for non-rigid Fuchsian systems.

Related to the Riemann-Hilbert problem, there is a natural problem to determine the condition on matrices  $B_0, B_1, \dots, B_p$  of Jordan canonical form such that there exists an irreducible system of Schlesinger canonical form with the residue matrices  $A_j$  conjugate to  $B_j$  for  $j = 0, \dots, p$ . An obvious necessary condition is the equality  $\sum_{j=0}^p \text{Trace } B_j = 0$ . A similar problem for monodromy generators, namely its multiplicative version, is equally formulated. The latter is called *multiplicative* version and the former is called *additive* version. Kostov [Ko, Ko2] called them Deligne-Simpson problems and gave an answer under a certain genericity condition. We note that the addition is a kind of a gauge transformation  $u(x) \mapsto (x - c)^\lambda u(x)$  and the middle convolution is essentially an Euler transformation or a transformation by an Riemann-Liouville integral  $u(x) \mapsto \frac{1}{\Gamma(\mu)} \int_c^x u(t)(x - t)^{\mu-1} dt$  or a fractional derivation.

Crawley-Boevey [CB] found a relation between the Deligne-Simpson problem and representations of certain quivers and gave an explicit answer for the additive Deligne-Simpson problem in terms of a Kac-Moody root system.

Yokoyama [Yo2] defined operations called extensions and restrictions on the systems of Fuchsian ordinary differential equations of Okubo normal form

$$(1.6) \quad (x - T) \frac{du}{dx} = Au.$$

Here  $A$  and  $T$  are constant square matrices such that  $T$  are diagonalizable. He proved that the irreducible rigid system of Okubo normal form is transformed into a trivial equation  $\frac{du}{dz} = 0$  by successive applications of his operations if the characteristic exponents are generic.

The relation between Katz's operations and Yokoyama's operations is clarified by [O7] and it is proved there that their algorithms of reductions of Fuchsian systems are equivalent and so are those of the constructions of the systems.

These operations are quite powerful and in fact if we fix the number of accessory parameters of the systems, they are connected into a finite number of fundamental systems (cf. [O6, Proposition 8.1 and Theorem 10.2] and Proposition 9.13), which is a generalization of the fact that the irreducible rigid Fuchsian system is connected to the trivial equation.

Hence it is quite useful to understand how does the property of the solutions transform under these operations. In this point of view, the system of the equations, the integral representation and the monodromy of the solutions are studied by [DR, DR2, HY] in the case of the Schlesinger canonical form. Moreover the equation describing the deformation preserving the monodromy of the solutions doesn't change, which is proved by [HF]. In the case of the Okubo normal form the corresponding transformation of the systems, that of the integral representations of the solutions and that of their connection coefficients are studied by [Yo2], [Ha] and [Yo3], respectively. These operation are explicit and hence it will be expected to have explicit results in general Fuchsian systems.

To avoid the specific forms of the differential equations, such as Schlesinger canonical form or Okubo normal form and moreover to make the explicit calculations easier under the transformations, we introduce certain operations on differential operators with polynomial coefficients in §2. The operations in §2 enables us to equally handle equations with irregular singularities or systems of equations with several variables.

The ring of differential operators with polynomial coefficients is called a *Weyl algebra* and denoted by  $W[x]$  in this paper. The endomorphisms of  $W[x]$  do not give a wide class of operations and Dixmier [Dix] conjectured that they are the automorphisms of  $W[x]$ . But we localize coordinate  $x$ , namely in the ring  $W(x)$  of differential operators with coefficients in rational functions, we have a wider class of operations.

For example, the transformation of the pair  $(x, \frac{d}{dx})$  into  $(x, \frac{d}{dx} - h(x))$  with any rational function  $h(x)$  induces an automorphism of  $W(x)$ . This operation is called a *gauge transformation*. The addition in [DR, DR2] corresponds to this operation with  $h(x) = \frac{\lambda}{x-c}$  and  $\lambda, c \in \mathbb{C}$ , which is denoted by  $\text{Ad}((x-c)^\lambda)$ .

The transformation of the pair  $(x, \frac{d}{dx})$  into  $(-\frac{d}{dx}, x)$  defines an important automorphism  $L$  of  $W[x]$ , which is called a *Laplace transformation*. In some cases the Fourier transformation is introduced and it is a similar transformation. Hence we may also localize  $\frac{d}{dx}$  and introduce the operators such as  $\lambda(\frac{d}{dx} - c)^{-1}$  and then the transformation of the pair  $(x, \frac{d}{dx})$  into  $(x - \lambda(\frac{d}{dx})^{-1}, \frac{d}{dx})$  defines an endomorphism in this localized ring, which corresponds to the middle convolution or an Euler transformation or a fractional derivation and is denoted by  $\text{Ad}(\partial^{-\lambda})$  or  $mc_\lambda$ . But the simultaneous localizations of  $x$  and  $\frac{d}{dx}$  produce the operator  $(\frac{d}{dx})^{-1} \circ x^{-1} = \sum_{k=0}^{\infty} k! x^{-k-1} (\frac{d}{dx})^{-k-1}$  which is not algebraic in our sense and hence we will not introduce such a microdifferential operator in this paper and we will not allow the simultaneous localizations of the operators.

Since our equation  $Pu = 0$  studied in this paper is defined on the Riemann sphere, we may replace the operator  $P$  in  $W(x)$  by a suitable representative  $\tilde{P} \in \mathbb{C}(x)P \cap W[x]$  with the minimal degree with respect to  $x$  and we put  $\text{R}P = \tilde{P}$ . Combining these operations including this replacement gives a wider class of operations on the Weyl algebra  $W[x]$ . In particular, the operator corresponding to the addition is  $\text{RAd}((x-c)^\lambda)$  and that corresponding to the middle convolution

is  $\text{RAd}(\partial^{-\mu})$  in our notation. The operations introduced in §2 correspond to certain transformations of solutions of the differential equations defined by elements of Weyl algebra and we call the calculation using these operations *fractional calculus of Weyl algebra*.

To understand our operations we show that, in Example 2.8, our operations enables us to construct Gauss hypergeometric equations, the equations satisfied by airy functions and Jordan-Pochhammer equations and to give the integral representations of their solutions.

In this paper we mainly study ordinary differential equations and since any ordinary differential equation is *cyclic*, namely, it is isomorphic to a single differential operator  $Pu = 0$  (cf. §2.4), we study a single ordinary differential equation  $Pu = 0$  with  $P \in W[x]$ . In many cases we are interested in a specific function  $u(x)$  which is characterized by differential equations and if  $u(x)$  is a function with the single variable  $x$ , the differential operators  $P \in W(x)$  satisfying  $Pu(x) = 0$  are generated by a single operator and hence it is naturally a single differential equation. A relation between our fractional calculus and Katz's middle convolution is briefly explained in §2.5.

In §3.1 we review fundamental results on Fuchsian ordinary differential equations. Our Weyl algebra  $W[x]$  is allowed to have some parameters  $\xi_1, \dots$  and in this case the algebra is denoted by  $W[x; \xi]$ . The position of singular points of the equations and the characteristic exponents there are usually the parameters and the analytic continuation of the parameters naturally leads the confluence of additions (cf. §3.3).

Combining this with our construction of equations leads the confluence of the equations. In the case of Jordan-Pochhammer equations, we have versal Jordan-Pochhammer equations. In the case of Gauss hypergeometric equation, we have a unified expression of Gauss hypergeometric equation, Kummer equation and Hermite-Weber equation and get a unified integral representation of their solutions (cf. Example 3.5). After this section in this paper, we mainly study single Fuchsian differential equations on the Riemann sphere. Equations with irregular singularities will be discussed elsewhere.

In §4 and §5 we examine the transformation of series expansions and contiguity relations of the solutions of Fuchsian differential equations under our operations.

The Fuchsian equation satisfied by the generalized hypergeometric series

$$(1.7) \quad {}_nF_{n-1}(\alpha_1, \dots, \alpha_n, \beta_1, \dots, \beta_{n-1}; x) = \sum_{k=0}^{\infty} \frac{(\alpha_1)_k \dots (\alpha_n)_k}{(\beta_1)_k \dots (\beta_{n-1})_{n-1} k!} x^k$$

with  $(\gamma)_k := \gamma(\gamma+1)\dots(\gamma+k-1)$

is characterized by the fact that it has  $(n-1)$ -dimensional local holomorphic solutions at  $x = 1$ , which is more precisely as follows. The set of characteristic exponents of the equation at  $x = 1$  equals  $\{0, 1, \dots, n-1, -\beta_n\}$  with  $\alpha_1 + \dots + \alpha_n = \beta_1 + \dots + \beta_n$  and those at 0 and  $\infty$  are  $\{1 - \beta_1, \dots, 1 - \beta_{n-1}, 0\}$  and  $\{\alpha_1, \dots, \alpha_n\}$ , respectively. Then if  $\alpha_i$  and  $\beta_j$  are generic, the Fuchsian differential equation  $Pu = 0$  is uniquely characterized by the fact that it has the above set of characteristic exponents at each singular point 0 or 1 or  $\infty$  and the monodromy generator around the point is *semisimple*, namely, the local solution around the singular point has no logarithmic term. We express this condition by the (generalized) Riemann scheme

$$(1.8) \quad \left\{ \begin{array}{ccc} x=0 & 1 & \infty \\ 1-\beta_1 & [0]_{(n-1)} & \alpha_1 \\ \vdots & & \vdots \\ 1-\beta_{n-1} & & \alpha_{n-1} \\ 0 & -\beta_n & \alpha_n \end{array} \right\}; x, \quad [\lambda]_{(k)} := \begin{pmatrix} \lambda \\ \lambda+1 \\ \vdots \\ \lambda+k-1 \end{pmatrix}.$$

In particular when  $n = 3$ , the (generalized) Riemann scheme is

$$\left\{ \begin{array}{cccc} x = 0 & 1 & \infty & \\ 1 - \beta_1 & \binom{0}{1} & \alpha_1 & \\ 1 - \beta_2 & & \alpha_2 & ; x \\ 0 & -\beta_3 & \alpha_3 & \end{array} \right\}.$$

The corresponding usual Riemann scheme is obtained from the generalized Riemann scheme by eliminating  $\left( \text{and} \right)$ . Here  $[0]_{(n-1)}$  in the above Riemann scheme means the characteristic exponents  $0, 1, \dots, n-2$  but it also indicates that the corresponding monodromy generator is semisimple in spite of integer differences of the characteristic exponents. Thus the set of (generalized) characteristic exponents  $\{[0]_{(n-1)}, -\beta_n\}$  at  $x = 1$  is defined. Here we remark that the coefficients of the Fuchsian differential operator  $P$  which is uniquely determined by the generalized Riemann scheme for generic  $\alpha_i$  and  $\beta_j$  are polynomial functions of  $\alpha_i$  and  $\beta_j$  and hence  $P$  is naturally defined for any  $\alpha_i$  and  $\beta_j$  as is given by (15.19). Similarly the Riemann scheme of Jordan-Pochhammer equation of order  $p$  is

$$(1.9) \quad \left\{ \begin{array}{cccccc} x = c_0 & c_1 & \cdots & c_{p-1} & \infty & \\ [0]_{(p-1)} & [0]_{(p-1)} & \cdots & [0]_{(p-1)} & [\lambda'_p]_{(p-1)} & ; x \\ \lambda_0 & \lambda_1 & \cdots & \lambda_{p-1} & \lambda_p & \end{array} \right\},$$

$$\lambda_0 + \cdots + \lambda_{p-1} + \lambda_p + (p-1)\lambda'_p = p-1.$$

The last equality in the above is called *Fuchs relation*.

In §6 we define the set of generalized characteristic exponents at a regular singular point of a differential equation  $Pu = 0$ . In fact when the order of  $P$  is  $n$ , it is the set  $\{[\lambda_1]_{(m_1)}, \dots, [\lambda_k]_{(m_k)}\}$  with a partition  $n = m_1 + \cdots + m_k$  and complex numbers  $\lambda_1, \dots, \lambda_k$ . It means that the set of characteristic exponents at the point equals  $\{\lambda_j + \nu; \nu = 0, \dots, m_j - 1 \text{ and } j = 1, \dots, k\}$  and the corresponding monodromy generator is semisimple if  $\lambda_i - \lambda_j \notin \mathbb{Z}$  for  $1 \leq i < j \leq k$ . In §6.1 we define the set of generalized characteristic exponents without the assumption  $\lambda_i - \lambda_j \notin \mathbb{Z}$  for  $1 \leq i < j \leq k$ . Here we only remark that when  $\lambda_i = \lambda_1$  for  $i = 1, \dots, k$ , it is also characterized by the fact that the Jordan normal form of the monodromy generator is defined by the dual partition of  $n = m_1 + \cdots + m_k$  together with the usual characteristic exponents.

Thus for a single Fuchsian differential equation  $Pu = 0$  on the Riemann sphere which has  $p+1$  regular singular points  $c_0, \dots, c_p$ , we define a (generalized) Riemann scheme

$$(1.10) \quad \left\{ \begin{array}{cccccc} x = c_0 & c_1 & \cdots & c_p & & \\ [\lambda_{0,1}]_{(m_{0,1})} & [\lambda_{1,1}]_{(m_{1,1})} & \cdots & [\lambda_{p,1}]_{(m_{p,1})} & & \\ \vdots & \vdots & \vdots & \vdots & & \\ [\lambda_{0,n_0}]_{(m_{0,n_0})} & [\lambda_{1,n_1}]_{(m_{1,n_1})} & \cdots & [\lambda_{p,n_p}]_{(m_{p,n_p})} & & ; x \end{array} \right\}.$$

Here  $n = m_{j,1} + \cdots + m_{j,n_j}$  for  $j = 0, \dots, p$  and  $n$  is the order of  $P$  and  $\lambda_{j,\nu} \in \mathbb{C}$ . The  $(p+1)$ -tuple of partitions of  $n$ , which is denoted by  $\mathbf{m} = (m_{j,\nu})_{\substack{j=0,\dots,p \\ \nu=1,\dots,n_j}}$ , is called the *spectral type* of  $P$  and the Riemann scheme (1.10). Here we note that the Riemann scheme (1.10) should always satisfy the Fuchs relation

$$(1.11) \quad |\{\lambda_{\mathbf{m}}\}| := \sum_{j=0}^p \sum_{\nu=1}^{n_p} m_{j,\nu} \lambda_{j,\nu} - \text{ord } \mathbf{m} + \frac{1}{2} \text{idx } \mathbf{m} = 0,$$

$$(1.12) \quad \text{idx } \mathbf{m} := \sum_{j=0}^p \sum_{\nu=1}^{n_p} m_{j,\nu}^2 - (p-1) \text{ord } \mathbf{m}.$$



Here  $\text{idx } \mathbf{m}$  coincides with the *index of rigidity* introduced by [Kz].

In §6, after introducing certain representatives of conjugacy classes of matrices and some notation and concepts related to tuples of partitions, we define that the tuple  $\mathbf{m}$  is *realizable* if there exists a Fuchsian differential operator  $P$  with the Riemann scheme (1.10) for generic complex numbers  $\lambda_{j,\nu}$  under the condition (1.11). Furthermore, if there exists such an operator  $P$  so that  $Pu = 0$  is irreducible, we define that  $\mathbf{m}$  is *irreducibly realizable*.

Lastly in §6, we examine the generalized Riemann schemes of the *product* of Fuchsian differential operators and the *dual* operators.

In §7 we examine the transformations of the Riemann scheme under our operations corresponding to the additions and the middle convolutions, which define transformations within Fuchsian differential operators. The operations induce transformations of spectral types of Fuchsian differential operators, which keep the indices of rigidity invariant but change the orders in general. Looking at the spectral types, we see that the combinatorial aspect of the reduction of Fuchsian differential operators is parallel to that of systems of Schlesinger canonical form.

As our interpretation of Deligne-Simpson problem introduced by Kostov, we examine the condition for the existence of a given Riemann scheme in §8. We determine the conditions on  $\mathbf{m}$  such that  $\mathbf{m}$  is realizable and irreducibly realizable, respectively, in Theorem 8.13. Moreover if  $\mathbf{m}$  is realizable, Theorem 8.13 gives an explicit construction of the *universal Fuchsian differential operator*

$$(1.13) \quad P_{\mathbf{m}} = \left( \prod_{j=1}^p (x - c_j)^n \right) \frac{d^n}{dx^n} + \sum_{k=0}^{n-1} a_k(x, \lambda, g) \frac{d^k}{dx^k},$$

$$\lambda = (\lambda_{j,\nu})_{\substack{j=0,\dots,p \\ \nu=1,\dots,n_j}}, \quad g = (g_1, \dots, g_N) \in \mathbb{C}^N$$

with the Riemann scheme (1.10), which has the following properties.

For fixed complex numbers  $\lambda_{j,\nu}$  satisfying (1.11) the operator with the Riemann scheme (1.10) satisfying  $c_0 = \infty$  equals  $P_{\mathbf{m}}$  for a suitable  $g \in \mathbb{C}^N$  up to a left multiplication by an element of  $\mathbb{C}(x)$  if  $\lambda_{j,\nu}$  are “generic” under the Fuchs relation (1.11) or  $\mathbf{m}$  is fundamental or *simply reducible* (cf. Definition 8.14 and §8.5), etc. Here  $g_1, \dots, g_N$  are called *accessory parameters* and if  $\mathbf{m}$  is irreducibly realizable,  $N = 1 - \frac{1}{2} \text{idx } \mathbf{m}$ . Moreover there exist a finite union of complex hyperplanes (cf. Remark 8.15) in the linear space of the parameters  $\lambda_{j,\nu}$  such that  $\lambda_{j,\nu}$  are “generic” if they do not belong to the union. In particular, if there is an irreducible and *locally non-degenerate* (cf. Definition 11.8) operator  $P$  with the Riemann scheme (1.10), then  $\lambda_{j,\nu}$  are “generic”.

The coefficients  $a_k(x, \lambda, g)$  of the differential operator  $P_{\mathbf{m}}$  are polynomials of the variables  $x$ ,  $\lambda$  and  $g$ . The coefficients satisfy  $\frac{\partial^2 a_k}{\partial g_\nu^2} = 0$  and furthermore  $g_\nu$  can be equal to suitable  $a_{i_\nu, j_\nu}$  under the expression  $P_{\mathbf{m}} = \sum a_{i,j} x^i \frac{d^j}{dx^j}$  and the pairs  $(i_\nu, j_\nu)$  for  $\nu = 1, \dots, N$  are explicitly given in the theorem.

The universal operator  $P_{\mathbf{m}}$  is a classically well-known operator in the case of Gauss hypergeometric equation, Jordan-Pochhammer equation or Heun’s equation etc. and the theorem assures the existence of such a good operator for any realizable tuple  $\mathbf{m}$ . We define the tuple  $\mathbf{m}$  is *rigid* if  $\mathbf{m}$  is irreducibly realizable and moreover  $N = 0$ , namely,  $P_{\mathbf{m}}$  is free from accessory parameters.

In particular the theorem gives the affirmative answer for the following question. Katz asked a question in the introduction in the book [Kz] whether a rigid local system is realized by a single Fuchsian differential equation  $Pu = 0$  without apparent singularities (cf. Corollary 12.12 iii)).

It is a natural problem to examine the Fuchsian differential equation  $P_{\mathbf{m}}u = 0$  with an irreducibly realizable spectral type  $\mathbf{m}$  which cannot be reduced to an

equation with a lower order by additions and middle convolutions. The tuple  $\mathbf{m}$  with this condition is called *fundamental*.

The equation  $P_{\mathbf{m}}u = 0$  with an irreducibly realizable spectral type  $\mathbf{m}$  can be transformed by the operation  $\partial_{max}$  (cf. Definition 7.6) into a Fuchsian equation  $P_{\mathbf{m}'}v = 0$  with a fundamental spectral type  $\mathbf{m}'$ . Namely, there exists a non-negative integer  $K$  such that  $P_{\mathbf{m}'} = \partial_{max}^K P_{\mathbf{m}}$  and we define  $f\mathbf{m} := \mathbf{m}'$ . Then it turns out that a realizable tuple  $\mathbf{m}$  is rigid if and only if the order of  $f\mathbf{m}$ , which is the order of  $P_{f\mathbf{m}}$  by definition, equals 1. Note that the operator  $\partial_{max}$  is essentially a product of suitable operators  $\text{RAd}((x - c_j)^{\lambda_j})$  and  $\text{RAd}(\partial^{-\mu})$ .

In this paper we study the transformations of several properties of the Fuchsian differential equation  $P_{\mathbf{m}}u = 0$  under the additions and middle convolutions. If they are understood well, the study of the properties are reduced to those of the equation  $P_{f\mathbf{m}}v = 0$ , which are of order 1 if  $\mathbf{m}$  is rigid. We note that there are many rigid spectral types  $\mathbf{m}$  and for example there are 187 different rigid spectral types  $\mathbf{m}$  with  $\text{ord } \mathbf{m} \leq 8$  as are given in §15.2.

The combinatorial aspect of transformations of the spectral type  $\mathbf{m}$  of the Fuchsian differential operator  $P$  induced from our fractional operations is described in §9 by using the terminology of a Kac-Moody root system  $(\Pi, W_{\infty})$  as in the case of the systems of Schlesinger canonical form studied by [CB]. Here  $\Pi$  is the fundamental system of a Kac-Moody root system with the following star-shaped Dynkin diagram and  $W_{\infty}$  is the Weyl group generated by the *simple reflections*  $s_{\alpha}$  for  $\alpha \in \Pi$ . The element of  $\Pi$  is called a *simple root*.

Associated to a tuple of  $(p + 1)$  partitions  $\mathbf{m}$  of a positive integer  $n$ , we define an element  $\alpha_{\mathbf{m}}$  in the positive root lattice (cf. §9.1, (9.5)):

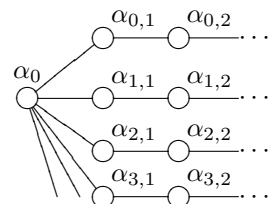
$$(1.14) \quad \begin{aligned} \Pi &:= \{\alpha_0, \alpha_{j,\nu}; j = 0, 1, \dots, \nu = 1, 2, \dots\}, \\ W_{\infty} &:= \langle s_{\alpha}; \alpha \in \Pi \rangle, \\ \alpha_{\mathbf{m}} &:= n\alpha_0 + \sum_{j=0}^p \sum_{\nu=1}^{n_j-1} \left( \sum_{i=\nu+1}^{n_j} m_{j,i} \right) \alpha_{j,\nu}, \\ (\alpha_{\mathbf{m}} | \alpha_{\mathbf{m}}) &= \text{idx } \mathbf{m}, \end{aligned}$$

We can define a fractional operation on  $P_{\mathbf{m}}$  which is compatible with the action of  $w \in W_{\infty}$  on the root lattice (cf. Theorem 9.5):

$$(1.15) \quad \begin{aligned} \{P_{\mathbf{m}} : \text{Fuchsian differential operators}\} &\rightarrow \{(\Lambda(\lambda), \alpha_{\mathbf{m}}); \alpha_{\mathbf{m}} \in \overline{\Delta}_+\} \\ \downarrow \text{fractional operations} &\quad \circ \quad \downarrow W_{\infty}\text{-action, } +\tau\Lambda_{0,j}^0 \\ \{P_{\mathbf{m}} : \text{Fuchsian differential operators}\} &\rightarrow \{(\Lambda(\lambda), \alpha_{\mathbf{m}}); \alpha_{\mathbf{m}} \in \overline{\Delta}_+\}. \end{aligned}$$

Here  $\tau \in \mathbb{C}$  and

$$(1.16) \quad \begin{aligned} \Lambda^0 &:= \alpha_0 + \sum_{\nu=1}^{\infty} (1 + \nu)\alpha_{0,\nu} + \sum_{j=1}^p \sum_{\nu=1}^{\infty} (1 - \nu)\alpha_{j,\nu}, \\ \Lambda_{i,j}^0 &:= \sum_{\nu=1}^{\infty} \nu(\alpha_{i,\nu} - \alpha_{j,\nu}), \\ \Lambda_0 &:= \frac{1}{2}\alpha_0 + \frac{1}{2} \sum_{j=0}^p \sum_{\nu=1}^{\infty} (1 - \nu)\alpha_{j,\nu}, \\ \Lambda(\lambda) &:= -\Lambda_0 - \sum_{j=0}^p \sum_{\nu=1}^{\infty} \left( \sum_{i=1}^{\nu} \lambda_{j,i} \right) \alpha_{j,\nu} \end{aligned}$$

and these linear combinations of infinite simple roots are identified with each other if their differences are in  $\mathbb{C}\Lambda^0$ .

The realizable tuples exactly correspond to the elements of the set  $\overline{\Delta}_+$  of positive integer multiples of the positive roots of the Kac-Moody root system whose support contains  $\alpha_0$  and the rigid tuples exactly correspond to the positive real roots whose support contain  $\alpha_0$ . For an element  $w \in W_\infty$  and an element  $\alpha \in \overline{\Delta}_+$  we do not consider  $w\alpha$  in the commutative diagram (1.15) when  $w\alpha \notin \overline{\Delta}_+$ .

Hence the fact that any irreducible rigid Fuchsian equation  $P_{\mathbf{m}}u = 0$  is transformed into the trivial equation  $\frac{dv}{dx} = 0$  by our invertible fractional operations corresponds to the fact that there exists  $w \in W_\infty$  such that  $w\alpha_{\mathbf{m}} = \alpha_0$  because  $\alpha_{\mathbf{m}}$  is a positive real root. The *monotone* fundamental tuples of partitions correspond to  $\alpha_0$  or the positive imaginary roots  $\alpha$  in the closed negative Weyl chamber which are indivisible or satisfies  $(\alpha|\alpha) < 0$ . A tuple of partitions  $\mathbf{m} = (m_{j,\nu})_{\substack{j=0,\dots,p \\ \nu=1,\dots,n_j}}$  is said to be monotone if  $m_{j,1} \geq m_{j,2} \geq \dots \geq m_{j,n_j}$  for  $j = 0, \dots, p$ . For example, we prove the exact estimate

$$(1.17) \quad \text{ord } \mathbf{m} \leq 3|\text{idx } \mathbf{m}| + 6$$

for any fundamental tuple  $\mathbf{m}$  in §9.2. Since we may assume

$$(1.18) \quad p \leq \frac{1}{2}|\text{idx } \mathbf{m}| + 3$$

for a fundamental tuple  $\mathbf{m}$ , there exist only finite number of monotone fundamental tuples with a fixed index of rigidity. We list the fundamental tuples of the index of rigidity 0 or  $-2$  in Remark 8.9 or Proposition 8.10, respectively.

Our results in §4, §7 and §8 give an integral expression and a power series expression of a local solution of the universal equation  $P_{\mathbf{m}}u = 0$  corresponding to the characteristic exponent whose multiplicity is free in the local monodromy. These expressions are in §10.

In §11.1 we review the monodromy of solutions of a Fuchsian differential equation from the view point of our operations. The theorems in this section are given by [DR, DR2, Kz, Ko]. In §11.2 we review Scott's lemma [Sc] and related results with their proofs, which are elementary but important for the study of the irreducibility of the monodromy.

In §12.1 we examine the condition for the decomposition  $P_{\mathbf{m}} = P_{\mathbf{m}'}P_{\mathbf{m}''}$  of universal operators with or without fixing the exponents  $\{\lambda_{j,\nu}\}$ , which implies the reducibility of the equation  $P_{\mathbf{m}}u = 0$ . In §12.2 we study the value of spectral parameters which makes the equation reducible and obtain Theorem 12.10. In particular we have a necessary and sufficient condition on characteristic exponents so that the monodromy of the solutions of the equation  $P_{\mathbf{m}}u = 0$  with a rigid spectral type  $\mathbf{m}$  is irreducible, which is given in Corollary 12.12 or Theorem 12.13. When  $m_{j,1} \geq m_{j,2} \geq \dots$  for any  $j \geq 0$ , the condition equals

$$(1.19) \quad (\Lambda(\lambda)|\alpha) \notin \mathbb{Z}$$

for all positive real roots  $\alpha$  of the Kac-Moody root system satisfying  $w_{\mathbf{m}}\alpha < 0$ . Here  $w_{\mathbf{m}}$  is the element of  $W_\infty$  with the minimal length so that  $\alpha_0 = w_{\mathbf{m}}\alpha_{\mathbf{m}}$  (cf. Definition 9.8 and Proposition 9.9 v)).

In §13 we construct shift operators between rigid Fuchsian differential equations with the same spectral type such that the differences of the corresponding characteristic exponents are integers. Theorem 13.3 gives a recurrence relation of certain solutions of the rigid Fuchsian equations, which is a generalization of the formula

$$(1.20) \quad c(F(a, b+1, c; x) - F(a, b, c; x)) = axF(a+1, b+1, c+1; x)$$

and moreover gives a relation between the universal operator and the shift operator with respect to the shift of characteristic exponents with free multiplicities.

The shift operators are useful for the study of Fuchsian differential equations when they are reducible because of special values of the characteristic exponents. Theorem 13.8 give a necessary condition and a sufficient condition so that the shift operator is bijective. In many cases we get a necessary and sufficient condition by this theorem. As an application of a shift operator we examine polynomial solutions of a rigid Fuchsian differential equation of Okubo type in §13.3.

In §14.1 we study a connection problem of the Fuchsian differential equation  $P_{\mathbf{m}}u = 0$ . First we give Lemma 14.2 which describes the transformation of a connection coefficient under an addition and a middle convolution. In particular, for the equation  $P_{\mathbf{m}}u = 0$  satisfying  $m_{0,n_0} = m_{1,n_1} = 1$ , Theorem 14.4 says that the connection coefficient  $c(c_0: \lambda_{0,n_0} \rightsquigarrow c_1: \lambda_{1,n_1})$  from the local solution corresponding to the exponent  $\lambda_{0,n_0}$  to that corresponding to  $\lambda_{1,n_1}$  in the Riemann scheme (1.10) equals the connection coefficient of the reduced equation  $P_{f\mathbf{m}}v = 0$  up to the gamma factors which are explicitly calculated.

In particular, if the equation is rigid, Theorem 14.6 explicitly gives the connection coefficient as a quotient of products of gamma functions and an easier non-zero term. For example, when  $p = 2$ , the easier term doesn't appear and the connection coefficient has the universal formula

$$(1.21) \quad c(c_0: \lambda_{0,n_0} \rightsquigarrow c_1: \lambda_{1,n_1}) = \frac{\prod_{\nu=1}^{n_0-1} \Gamma(\lambda_{0,n_0} - \lambda_{0,\nu} + 1) \cdot \prod_{\nu=1}^{n_1-1} \Gamma(\lambda_{1,\nu} - \lambda_{1,n_1})}{\prod_{\substack{\mathbf{m}' \oplus \mathbf{m}'' = \mathbf{m} \\ m'_{0,n_0} = m''_{1,n_1} = 1}} \Gamma(|\{\lambda_{\mathbf{m}'}\}|)}.$$

Here the notation (1.11) is used and  $\mathbf{m} = \mathbf{m}' \oplus \mathbf{m}''$  means that  $\mathbf{m} = \mathbf{m}' + \mathbf{m}''$  with rigid tuples  $\mathbf{m}'$  and  $\mathbf{m}''$ . Moreover the number of Gamma factors in the above denominator is equals to that of the numerator. The author conjectured this formula in 2007 and proved it in 2008 (cf. [O6]). The proof in §14.1 is different from the original proof, which is explained in §14.3.

The hypergeometric series  $F(a, b, c; x)$  satisfies  $\lim_{k \rightarrow +\infty} F(a, b, c + k; x) = 1$  if  $|x| \leq 1$ , which obviously implies  $\lim_{k \rightarrow +\infty} F(a, b, c + k; 1) = 1$ . Gauss proves the summation formula (1.3) by this limit formula and the recurrence relation  $F(a, b, c; 1) = \frac{(c-a)(c-b)}{c(c-a-b)} F(a, b, c + 1; 1)$ . We have  $\lim_{k \rightarrow +\infty} c(c_0: \lambda_{0,n_0} + k \rightsquigarrow c_1: \lambda_{1,n_1} - k) = 1$  in the connection formula (1.21) (cf. Corollary 14.7). This suggests a similar limit formula for a local solution of a general Fuchsian differential equation, which is given in §14.2.

In §14.3 we propose a procedure to calculate the connection coefficient (cf. Remark 14.19), which is based on the calculation of its zeros and poles. This procedure is different from the proof of Theorem 14.6 in §14.1 and useful to calculate a certain connection coefficient between local solutions with multiplicities in eigenvalues of local monodromies. The coefficient is defined in Definition 14.17.

In §15 we show many examples which explain our fractional calculus in this paper and also give concrete results of the calculus. In §15.1 we list all the fundamental tuples whose indices of rigidity are not smaller than  $-6$  and in §15.2 we list all the rigid tuples whose orders are not larger than 8, most of which are calculated by a computer program `okubo` explained in §15.11. In §15.3 and §15.4 we apply our fractional calculus to Jordan-Pochhammer equations and the hypergeometric family, respectively, which helps us to understand our unifying study of rigid Fuchsian differential equations. In §15.5 we apply our fractional calculus to the even/odd family classified by [Si] and most of the results there have been first obtained by the calculus.

In §15.7, §15.8 and §15.9 we study the rigid Fuchsian differential equations of order not larger than 4 and those of order 5 or 6 and the equations belonging to 12 submaximal series classified by [Ro], respectively. Note that these 12 maximal series contain Yokoyama's list [Yo]. In §15.9.2, we explain how we read the condition of irreducibility and the connection coefficients etc. of the corresponding differential equation from the given data in §15.7–§15.9. In §15.6, we show some interesting identities of trigonometric functions as a consequence of the concrete value (1.21) of connection coefficients. We examine Appell's hypergeometric equations in §15.10 by our fractional calculus, which will be further discussed in another paper.

In §16 we give some problems to be studied related to the results in this paper.

In §17 a theorem on Coxeter groups is given, which was proved by K. Nuida through a private communication between the author and Nuida. The theorem is useful for the study of the difference of various reductions of Fuchsian differential equations (cf. Proposition 9.9 v). The author greatly thanks Nuida for allowing the author to put the theorem with its proof in this paper.

The author express his sincere gratitude to Kazuo Okamoto and Yoshishige Haraoka for the guidance to the subjects developed in this paper and to Kazuki Hiroe for reading the manuscript of this paper.

## 2. FRACTIONAL OPERATIONS

**2.1. Weyl algebra.** In this section we define several operations on a Weyl algebra. The operations are elementary or well-known but their combinations will be important.

Let  $\mathbb{C}[x_1, \dots, x_n]$  denote the polynomial ring of  $n$  independent variables  $x_1, \dots, x_n$  over  $\mathbb{C}$  and let  $\mathbb{C}(x_1, \dots, x_n)$  denote the quotient field of  $\mathbb{C}[x_1, \dots, x_n]$ . The Weyl algebra  $W[x_1, \dots, x_n]$  of  $n$  variables  $x_1, \dots, x_n$  is the algebra over  $\mathbb{C}$  generated by  $x_1, \dots, x_n$  and  $\frac{\partial}{\partial x_1}, \dots, \frac{\partial}{\partial x_n}$  with the fundamental relation

$$(2.1) \quad [x_i, x_j] = [\frac{\partial}{\partial x_i}, \frac{\partial}{\partial x_j}] = 0, \quad [\frac{\partial}{\partial x_i}, x_j] = \delta_{i,j} \quad (1 \leq i, j \leq n).$$

We introduce a Weyl algebra  $W[x_1, \dots, x_n][\xi_1, \dots, \xi_n]$  with parameters  $\xi_1, \dots, \xi_n$  by

$$W[x_1, \dots, x_n][\xi_1, \dots, \xi_n] := \mathbb{C}[\xi_1, \dots, \xi_n] \otimes_{\mathbb{C}} W[x_1, \dots, x_n]$$

and put

$$W[x_1, \dots, x_n; \xi_1, \dots, \xi_n] := \mathbb{C}(\xi_1, \dots, \xi_n) \otimes_{\mathbb{C}} W[x_1, \dots, x_n],$$

$$W(x_1, \dots, x_n; \xi_1, \dots, \xi_n) := \mathbb{C}(x_1, \dots, x_n, \xi_1, \dots, \xi_n) \otimes_{\mathbb{C}[x_1, \dots, x_n]} W[x_1, \dots, x_n].$$

Here we have

$$(2.2) \quad [x_i, \xi_\nu] = [\frac{\partial}{\partial x_i}, \xi_\nu] = 0 \quad (1 \leq i \leq n, 1 \leq \nu \leq N),$$

$$(2.3) \quad \begin{aligned} \left[ \frac{\partial}{\partial x_i}, \frac{g}{f} \right] &= \frac{\partial}{\partial x_i} \left( \frac{g}{f} \right) \\ &= \frac{\frac{\partial g}{\partial x_i} \cdot f - g \cdot \frac{\partial f}{\partial x_i}}{f^2} \quad (f, g \in \mathbb{C}[x_1, \dots, x_n, \xi_1, \dots, \xi_n]) \end{aligned}$$

and  $[\frac{\partial}{\partial x_i}, f] = \frac{\partial f}{\partial x_i} \in \mathbb{C}[x_1, \dots, x_n, \xi_1, \dots, \xi_n]$ .

For simplicity we put  $x = (x_1, \dots, x_n)$  and  $\xi = (\xi_1, \dots, \xi_n)$  and the algebras  $\mathbb{C}[x_1, \dots, x_n]$ ,  $\mathbb{C}(x_1, \dots, x_n)$ ,  $W[x_1, \dots, x_n][\xi_1, \dots, \xi_n]$ ,  $W[x_1, \dots, x_n; \xi_1, \dots, \xi_n]$ ,  $W(x_1, \dots, x_n; \xi_1, \dots, \xi_n)$  etc. are also denoted by  $\mathbb{C}[x]$ ,  $\mathbb{C}(x)$ ,  $W[x][\xi]$ ,  $W[x; \xi]$ ,  $W(x; \xi)$  etc., respectively. Then

$$(2.4) \quad \mathbb{C}[x, \xi] \subset W[x][\xi] \subset W[x; \xi] \subset W(x; \xi).$$

The element  $P$  of  $W(x; \xi)$  is uniquely written by

$$(2.5) \quad P = \sum_{\alpha=(\alpha_1, \dots, \alpha_n) \in \mathbb{Z}_{\geq 0}^n} p_\alpha(x, \xi) \frac{\partial^{\alpha_1 + \dots + \alpha_n}}{\partial x_1^{\alpha_1} \dots \partial x_n^{\alpha_n}} \quad (p_\alpha(x, \xi) \in \mathbb{C}(x, \xi)).$$

Here  $\mathbb{Z}_{\geq 0} = \{0, 1, 2, \dots\}$ . If  $P \in W(x; \xi)$  is not zero, the maximal integer  $\alpha_1 + \dots + \alpha_n$  satisfying  $p_\alpha(x, \xi) \neq 0$  is called the *order* of  $P$  and denoted by  $\text{ord } P$ . If  $P \in W[x; \xi]$ ,  $p_\alpha(x, \xi)$  are polynomials of  $x$  with coefficients in  $\mathbb{C}(\xi)$  and the maximal degree of  $p_\alpha(x, \xi)$  as polynomials of  $x$  is called the *degree* of  $P$  and denoted by  $\text{deg } P$ .

**2.2. Laplace and gauge transformations and reduced representatives.** First we will define some fundamental operations on  $W[x; \xi]$ .

**Definition 2.1.** i) For a non-zero element  $P \in W(x; \xi)$  we choose an element  $(\mathbb{C}(x, \xi) \setminus \{0\})P \cap W[x; \xi]$  with the minimal degree and denote it by  $\text{R}P$  and call it a *reduced representative* of  $P$ . If  $P = 0$ , we put  $\text{R}P = 0$ . Note that  $\text{R}P$  is determined up to multiples by non-zero elements of  $\mathbb{C}(\xi)$ .

ii) For a subset  $I$  of  $\{1, \dots, n\}$  we define an automorphism  $\text{L}_I$  of  $W[x; \xi]$ :

$$(2.6) \quad \text{L}_I\left(\frac{\partial}{\partial x_i}\right) = \begin{cases} x_i & (i \in I) \\ \frac{\partial}{\partial x_i} & (i \notin I) \end{cases}, \quad \text{L}_I(x_i) = \begin{cases} -\frac{\partial}{\partial x_i} & (i \in I) \\ x_i & (i \notin I) \end{cases} \quad \text{and} \quad \text{L}_I(\xi_\nu) = \xi_\nu.$$

We put  $\text{L} = \text{L}_{\{1, \dots, n\}}$  and call  $\text{L}$  the *Laplace transformation* of  $W[x; \xi]$ .

iii) Let  $W_L(x; \xi)$  be the algebra isomorphic to  $W(x; \xi)$  which is defined by the Laplace transformation

$$(2.7) \quad \text{L} : W(x; \xi) \xrightarrow{\sim} W_L(x; \xi) \xrightarrow{\sim} W(x; \xi).$$

For an element  $P \in W_L(x; \xi)$  we define

$$(2.8) \quad \text{R}_L(P) := \text{L}^{-1} \circ \text{R} \circ \text{L}(P).$$

Note that the element of  $W_L(x; \xi)$  is a finite sum of products of elements of  $\mathbb{C}[x]$  and rational functions of  $(\frac{\partial}{\partial x_1}, \dots, \frac{\partial}{\partial x_n}, \xi_1, \dots, \xi_n)$ .

We will introduce an automorphism of  $W(x; \xi)$ .

**Definition 2.2** (Gauge transformation). Fix an element  $(h_1, \dots, h_n) \in \mathbb{C}(x, \xi)^n$  satisfying

$$(2.9) \quad \frac{\partial h_i}{\partial x_j} = \frac{\partial h_j}{\partial x_i} \quad (1 \leq i, j \leq n).$$

We define an automorphism  $\text{Adei}(h_1, \dots, h_n)$  of  $W(x; \xi)$  by

$$(2.10) \quad \begin{aligned} \text{Adei}(h_1, \dots, h_n)(x_i) &= x_i & (i = 1, \dots, n), \\ \text{Adei}(h_1, \dots, h_n)\left(\frac{\partial}{\partial x_i}\right) &= \frac{\partial}{\partial x_i} - h_i & (i = 1, \dots, n), \\ \text{Adei}(h_1, \dots, h_n)(\xi_\nu) &= \xi_\nu & (\nu = 1, \dots, N). \end{aligned}$$

Choose functions  $f$  and  $g$  satisfying  $\frac{\partial g}{\partial x_i} = h_i$  for  $i = 1, \dots, n$  and put  $f = e^g$  and

$$(2.11) \quad \text{Ad}(f) = \text{Ade}(g) = \text{Adei}(h_1, \dots, h_n).$$

We will define a homomorphism of  $W(x; \xi)$ .

**Definition 2.3** (Coordinate transformation). Let  $\phi = (\phi_1, \dots, \phi_n)$  be an element of  $\mathbb{C}(x_1, \dots, x_m, \xi)^n$  such that the rank of the matrix

$$(2.12) \quad \Phi := \left( \frac{\partial \phi_j}{\partial x_i} \right)_{\substack{1 \leq i \leq m \\ 1 \leq j \leq n}}$$

equals  $n$  for a generic point  $(x, \xi) \in \mathbb{C}^{m+N}$ . Let  $\Psi = (\psi_{i,j}(x, \xi))_{\substack{1 \leq i \leq n \\ 1 \leq j \leq m}}$  be an left inverse of  $\Phi$ , namely,  $\Psi\Phi$  is an identity matrix of size  $n$  and  $m \geq n$ . Then a homomorphism  $T_\phi^*$  from  $W(x_1, \dots, x_n; \xi)$  to  $W(x_1, \dots, x_m; \xi)$  is defined by

$$(2.13) \quad \begin{aligned} T_\phi^*(x_i) &= \phi_i(x) & (1 \leq i \leq n), \\ T_\phi^*\left(\frac{\partial}{\partial x_i}\right) &= \sum_{j=1}^m \psi_{i,j}(x, \xi) \frac{\partial}{\partial x_j} & (1 \leq i \leq n). \end{aligned}$$

If  $m > n$ , we choose linearly independent elements  $h_\nu = (h_{\nu,1}, \dots, h_{\nu,m})$  of  $\mathbb{C}(x, \xi)^m$  for  $\nu = 1, \dots, m-n$  such that  $\psi_{i,1}h_{\nu,1} + \dots + \psi_{i,m}h_{\nu,m} = 0$  for  $i = 1, \dots, n$  and  $\nu = 1, \dots, m-n$  and put

$$(2.14) \quad \mathcal{K}^*(\phi) := \sum_{\nu=1}^{m-n} \mathbb{C}(x, \xi) \sum_{j=1}^m h_{\nu,j} \frac{\partial}{\partial x_j} \in W(x; \xi).$$

The meaning of these operations are clear as follows.

*Remark 2.4.* Let  $P$  be an element of  $W(x; \xi)$  and let  $u(x)$  be an analytic solution of the equation  $Pu = 0$  with a parameter  $\xi$ . Then under the notation in Definitions 2.1–2.2, we have  $(RP)u(x) = (\text{Ad}(f)(P))(f(x)u(x)) = 0$ . Note that  $RP$  is defined up to the multiplications of non-zero elements of  $\mathbb{C}(\xi)$ .

If a Laplace transform

$$(2.15) \quad (\mathcal{R}_k u)(x) = \int_C e^{-x_1 t_1 - \dots - x_k t_k} u(t_1, \dots, t_k, x_{k+1}, \dots, x_n) dt_1 \cdots dt_k$$

of  $u(x)$  is suitably defined, then  $(L_{\{1, \dots, k\}}(RP))(\mathcal{R}_k u) = 0$ , which follows from the equalities  $\frac{\partial \mathcal{R}_k u}{\partial x_i} = \mathcal{R}_k(-x_i u)$  and  $0 = \int_C \frac{\partial}{\partial t_i} (e^{-x_1 t_1 - \dots - x_k t_k} u(t, x_{k+1}, \dots)) dt = -x_i \mathcal{R}_k u + \mathcal{R}_k\left(\frac{\partial u}{\partial t_i}\right)$  for  $i = 1, \dots, k$ . Moreover we have

$$f(x) \mathcal{R}_k R P u = f(x) (L_{\{1, \dots, k\}}(RP))(\mathcal{R}_k u) = (\text{Ad}(f) L_{\{1, \dots, k\}}(RP))(f(x) \mathcal{R}_k u).$$

Under the notation of Definition 2.3, we have  $T_\phi^*(P)u(\phi_1(x), \dots, \phi_n(x)) = 0$  and  $Qu(\phi_1(x), \dots, \phi_n(x)) = 0$  for  $Q \in \mathcal{K}^*(\phi)$ .

Another transformation of  $W[x; \xi]$  based on an integral transformation frequently used will be given in Proposition 15.1.

We introduce some notation for combinations of operators we have defined.

**Definition 2.5.** Retain the notation in Definition 2.1–2.3 and recall that  $f = e^g$  and  $h_i = \frac{\partial g}{\partial x_i}$ .

$$(2.16) \quad \text{RAd}(f) = \text{RAde}(g) = \text{RAdei}(h_1, \dots, h_n) := \text{R} \circ \text{Adei}(h_1, \dots, h_n),$$

$$(2.17) \quad \begin{aligned} \text{AdL}(f) &= \text{AdeL}(h) = \text{AdeiL}(h_1, \dots, h_n) \\ &:= \text{L}^{-1} \circ \text{Adei}(h_1, \dots, h_n) \circ \text{L}, \end{aligned}$$

$$(2.18) \quad \begin{aligned} \text{RAdL}(f) &= \text{RAdel}(h) = \text{RAdeiL}(h_1, \dots, h_n) \\ &:= \text{L}^{-1} \circ \text{RAdei}(h_1, \dots, h_n) \circ \text{L}, \end{aligned}$$

$$(2.19) \quad \text{Ad}(\partial_{x_i}^\mu) := \text{L}^{-1} \circ \text{Ad}(x_i^\mu) \circ \text{L},$$

$$(2.20) \quad \text{RAd}(\partial_{x_i}^\mu) := \text{L}^{-1} \circ \text{RAd}(x_i^\mu) \circ \text{L}.$$

Here  $\mu$  is a complex number or an element of  $\mathbb{C}(\xi)$  and  $\text{Ad}(\partial_{x_i}^\mu)$  defines an endomorphism of  $W_L(x; \xi)$ .

We will sometimes denote  $\frac{\partial}{\partial x_i}$  by  $\partial_{x_i}$  or  $\partial_i$  for simplicity. If  $n = 1$ , we usually denote  $x_1$  by  $x$  and  $\frac{\partial}{\partial x_1}$  by  $\frac{d}{dx}$  or  $\partial_x$  or  $\partial$ . We will give some examples.

Since the calculation  $\text{Ad}(x^{-\mu})\partial = x^{-\mu} \circ \partial \circ x^{\mu} = x^{-\mu}(x^{\mu}\partial + \mu x^{\mu-1}) = \partial + \mu x^{-1}$  is allowed, the following calculation is justified by the isomorphism (2.7):

$$\begin{aligned} \text{Ad}(\partial^{-\mu})x^m &= \partial^{-\mu} \circ x^m \circ \partial^{\mu} \\ &= (x^m \partial^{-\mu} + \frac{(-\mu)m}{1!} x^{m-1} \partial^{-\mu-1} + \frac{(-\mu)(-\mu-1)m(m-1)}{2!} x^{m-2} \partial^{-\mu-2} \\ &\quad + \dots + \frac{(-\mu)(-\mu-1)\dots(-\mu-m+1)m!}{m!} \partial^{-\mu-m}) \partial^{\mu} \\ &= \sum_{\nu=0}^m (-1)^{\nu} (\mu)_{\nu} \binom{m}{\nu} x^{m-\nu} \partial^{-\nu}. \end{aligned}$$

This calculation is in a ring of certain pseudo-differential operators according to Leibniz's rule. In general we may put  $\text{Ad}(\partial^{-\mu})P = \partial^{-\mu} \circ P \circ \partial^{\mu}$  for  $P \in W[x; \xi]$  under Leibniz's rule. Here  $m$  is a positive integer and we use the notation

$$(2.21) \quad (\mu)_{\nu} := \prod_{i=0}^{\nu-1} (\mu + i), \quad \binom{m}{\nu} := \frac{\Gamma(m+1)}{\Gamma(m-\nu+1)\Gamma(\nu+1)} = \frac{m!}{(m-\nu)!\nu!}.$$

**2.3. Examples of ordinary differential operators.** In this paper we mainly study ordinary differential operators. We give examples of the operations we have defined, which are related to classical differential equations.

**Example 2.6** ( $n = 1$ ). For a rational function  $h(x, \xi)$  of  $x$  with a parameter  $\xi$  we denote by  $\int h(x, \xi) dx$  the function  $g(x, \xi)$  satisfying  $\frac{d}{dx}g(x, \xi) = h(x, \xi)$ . Put  $f(x, \xi) = e^{g(x, \xi)}$  and define

$$(2.22) \quad \vartheta := x \frac{d}{dx}.$$

Then we have the following identities.

$$(2.23) \quad \text{Adei}(h)\partial = \partial - h = \text{Ad}(e^{\int h(x) dx})\partial = e^{\int h(x) dx} \circ \partial \circ e^{-\int h(x) dx},$$

$$(2.24) \quad \text{Ad}(f)x = x, \quad \text{AdL}(f)\partial = \partial,$$

$$(2.25) \quad \text{Ad}(\lambda f) = \text{Ad}(f) \quad \text{AdL}(\lambda f) = \text{AdL}(f),$$

$$(2.26) \quad \text{Ad}(f)\partial = \partial - h(x, \xi) \Rightarrow \text{AdL}(f)x = x + h(\partial, \xi),$$

$$(2.27) \quad \text{Ad}((x-c)^{\lambda}) = \text{Ade}(\lambda \log(x-c)) = \text{Adei}\left(\frac{\lambda}{x-c}\right),$$

$$(2.28) \quad \text{Ad}((x-c)^{\lambda})x = x, \quad \text{Ad}((x-c)^{\lambda})\partial = \partial - \frac{\lambda}{x-c},$$

$$(2.29) \quad \text{RAd}((x-c)^{\lambda})\partial = \text{Ad}((x-c)^{\lambda})((x-c)\partial) = (x-c)\partial - \lambda,$$

$$(2.30) \quad \begin{aligned} \text{RAdL}((x-c)^{\lambda})x &= L^{-1} \circ \text{RAd}((x-c)^{\lambda})(-\partial) \\ &= L^{-1}((x-c)(-\partial) + \lambda) \\ &= (\partial - c)x + \lambda = x\partial - cx + 1 + \lambda, \end{aligned}$$

$$(2.31) \quad \text{RAdL}((x-c)^{\lambda})\partial = \partial, \quad \text{RAdL}((x-c)^{\lambda})((\partial - c)x) = (\partial - c)x + \lambda,$$

$$(2.32) \quad \text{Ad}(\partial^{\lambda})\vartheta = \text{AdL}(x^{\lambda})\vartheta = \vartheta + \lambda,$$

$$(2.33) \quad \text{Ad}\left(e^{\frac{\lambda(x-c)^m}{m}}\right)x = x, \quad \text{Ad}\left(e^{\frac{\lambda(x-c)^m}{m}}\right)\partial = \partial - \lambda(x-c)^{m-1},$$

$$(2.34) \quad \text{RAdL}\left(e^{\frac{\lambda(x-c)^m}{m}}\right)x = \begin{cases} x + \lambda(\partial - c)^{m-1} & (m \geq 1), \\ (\partial - c)^{1-m}x + \lambda & (m \leq -1), \end{cases}$$

$$(2.35) \quad T_{(x-c)^m}^*(x) = (x-c)^m, \quad T_{(x-c)^m}^*(\partial) = \frac{1}{m}(x-c)^{1-m}\partial.$$

Here  $m$  is a non-zero integer and  $\lambda$  is a non-zero complex number.



Some operations are related to Katz's operations defined by [Kz]. The operation  $\text{RAd}((x-c)^\mu)$  corresponds to the *addition* given in [DR] and the operator

$$(2.36) \quad mc_\mu := \text{RAd}(\partial^{-\mu}) = \text{RAdL}(x^{-\mu})$$

corresponds to Katz's *middle convolution* and the Euler transformation or the Riemann-Liouville integral (cf. [Kh, §5.1]) or the fractional derivation

$$(2.37) \quad (I_c^\mu(u))(x) = \frac{1}{\Gamma(\mu)} \int_c^x u(t)(x-t)^{\mu-1} dt.$$

Here  $c$  is suitably chosen. In most cases,  $c$  is a singular point of the multi-valued holomorphic function  $u(x)$ . The integration may be understood through an analytic continuation with respect to a parameter or in the sense of generalized functions. When  $u(x)$  is a multi-valued holomorphic function on the punctured disk around  $c$ , we can define the complex integral

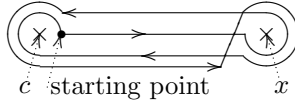
$$(2.38) \quad (\tilde{I}_c^\mu(u))(x) := \int^{(x+, c+, x-, c-)} u(z)(x-z)^{\mu-1} dz$$

through Pochhammer contour  $(x+, c+, x-, c-)$  along a double loop circuit (cf. [WW, 12.43]). If  $(z-c)^{-\lambda}u(z)$  is a meromorphic function in a neighborhood of the point  $c$ , we have

$$(2.39) \quad (\tilde{I}_c^\mu(u))(x) = (1 - e^{2\pi\lambda\sqrt{-1}})(1 - e^{2\pi\mu\sqrt{-1}}) \int_c^x u(t)(x-t)^{\mu-1} dt.$$

For example, we have

$$(2.40) \quad \begin{aligned} I_c^\mu((x-c)^\lambda) &= \frac{1}{\Gamma(\mu)} \int_c^x (t-c)^\lambda (x-t)^{\mu-1} dt \\ &= \frac{(x-c)^{\lambda+\mu}}{\Gamma(\mu)} \int_0^1 s^\lambda (1-s)^{\mu-1} ds \quad (x-t = (1-s)(x-c)) \\ &= \frac{\Gamma(\lambda+1)}{\Gamma(\lambda+\mu+1)} (x-c)^{\lambda+\mu}, \end{aligned}$$

$$(2.41) \quad \tilde{I}_c^\mu((x-c)^\lambda) = \frac{4\pi^2 e^{\pi(\lambda+\mu)\sqrt{-1}}}{\Gamma(-\lambda)\Gamma(1-\mu)\Gamma(\lambda+\mu+1)} (x-c)^{\lambda+\mu+1}.$$

For  $k \in \mathbb{Z}_{\geq 0}$  we have

$$(2.42) \quad \tilde{I}_c^\mu((x-c)^k \log(x-c)) = \frac{-4\pi^2 k! e^{\pi\lambda\sqrt{-1}}}{\Gamma(1-\mu)\Gamma(\mu+k+1)} (x-c)^{\mu+k+1}.$$

We note that since

$$\frac{d}{dt}(u(t)(x-t)^{\mu-1}) = u'(t)(x-t)^{\mu-1} - \frac{d}{dx}(u(t)(x-t)^{\mu-1})$$

and

$$\begin{aligned} \frac{d}{dt}(u(t)(x-t)^\mu) &= u'(t)(x-t)^\mu - u(t) \frac{d}{dx}(x-t)^\mu \\ &= xu'(t)(x-t)^{\mu-1} - tu'(t)(x-t)^{\mu-1} - \mu u(t)(x-t)^{\mu-1}, \end{aligned}$$

we have

$$(2.43) \quad \begin{aligned} I_c^\mu(\partial u) &= \partial I_c^\mu(u), \\ I_c^\mu(\vartheta u) &= (\vartheta - \mu)I_c^\mu(u). \end{aligned}$$

*Remark 2.7.* i) The integral (2.37) is naturally well-defined and the equalities (2.43) are valid if  $\operatorname{Re} \lambda > 1$  and  $\lim_{x \rightarrow c} x^{-1}u(x) = 0$ . Depending on the definition of  $I_c^\lambda$ , they are also valid in many cases, which can be usually proved in this paper by analytic continuations with respect to certain parameters (for example cf. (4.6)). Note that (2.43) is valid if  $I_c^\mu$  is replaced by  $\tilde{I}_c^\mu$  defined by (2.38).

ii) Let  $\epsilon$  be a positive number and let  $u(x)$  be a holomorphic function on

$$U_{\epsilon, \theta}^+ := \{x \in \mathbb{C}; |x - c| < \epsilon \text{ and } e^{-i\theta}(x - c) \notin (-\infty, 0]\}.$$

Suppose that there exists a positive number  $\delta$  such that  $|u(x)(x - c)^{-k}|$  is bounded on  $\{x \in U_{\epsilon, \theta}^+; |\operatorname{Arg}(x - c) - \theta| < \delta\}$  for any  $k > 0$ . Note that the function  $Pu(x)$  also satisfies this estimate for  $P \in W[x]$ . Then the integration (2.37) is defined along a suitable path  $C : \gamma(t)$  ( $0 \leq t \leq 1$ ) such that  $\gamma(0) = c$ ,  $\gamma(1) = x$  and  $|\operatorname{Arg}(\gamma(t) - c) - \theta| < \delta$  for  $0 < t < \frac{1}{2}$  and the equalities (2.43) are valid.

**Example 2.8.** We apply additions, middle convolutions and Laplace transformations to the trivial ordinary differential equation

$$(2.44) \quad \frac{du}{dx} = 0,$$

which has the solution  $u(x) \equiv 1$ .

i) (Gauss hypergeometric equation). Put

$$(2.45) \quad \begin{aligned} P_{\lambda_1, \lambda_2, \mu} &:= \operatorname{RAd}(\partial^{-\mu}) \circ \operatorname{RAd}(x^{\lambda_1}(1-x)^{\lambda_2})\partial \\ &= \operatorname{RAd}(\partial^{-\mu}) \circ \operatorname{R}(\partial - \frac{\lambda_1}{x} + \frac{\lambda_2}{1-x}) \\ &= \operatorname{RAd}(\partial^{-\mu})(x(1-x)\partial - \lambda_1(1-x) + \lambda_2x) \\ &= \operatorname{RAd}(\partial^{-\mu})((\vartheta - \lambda_1) - x(\vartheta - \lambda_1 - \lambda_2)) \\ &= \operatorname{Ad}(\partial^{-\mu})((\vartheta + 1 - \lambda_1)\partial - (\vartheta + 1)(\vartheta - \lambda_1 - \lambda_2)) \\ &= (\vartheta + 1 - \lambda_1 - \mu)\partial - (\vartheta + 1 - \mu)(\vartheta - \lambda_1 - \lambda_2 - \mu) \\ &= (\vartheta + \gamma)\partial - (\vartheta + \beta)(\vartheta + \alpha) \\ &= x(1-x)\partial^2 + (\gamma - (\alpha + \beta + 1)x)\partial - \alpha\beta \end{aligned}$$

with

$$(2.46) \quad \begin{cases} \alpha = -\lambda_1 - \lambda_2 - \mu, \\ \beta = 1 - \mu, \\ \gamma = 1 - \lambda_1 - \mu. \end{cases}$$

We have a solution

$$(2.47) \quad \begin{aligned} u(x) &= I_0^\mu(x^{\lambda_1}(1-x)^{\lambda_2}) \\ &= \frac{1}{\Gamma(\mu)} \int_0^x t^{\lambda_1}(1-t)^{\lambda_2}(x-t)^{\mu-1} dt \\ &= \frac{x^{\lambda_1+\mu}}{\Gamma(\mu)} \int_0^1 s^{\lambda_1}(1-s)^{\mu-1}(1-xs)^{\lambda_2} ds \quad (t = xs) \\ &= \frac{\Gamma(\lambda_1 + 1)x^{\lambda_1+\mu}}{\Gamma(\lambda_1 + \mu + 1)} F(-\lambda_2, \lambda_1 + 1, \lambda_1 + \mu + 1; x) \\ &= \frac{\Gamma(\lambda_1 + 1)x^{\lambda_1+\mu}(1-x)^{\lambda_2+\mu}}{\Gamma(\lambda_1 + \mu + 1)} F(\mu, \lambda_1 + \lambda_2 + \mu, \lambda_1 + \mu + 1; x) \\ &= \frac{\Gamma(\lambda_1 + 1)x^{\lambda_1+\mu}(1-x)^{-\lambda_2}}{\Gamma(\lambda_1 + \mu + 1)} F(\mu, -\lambda_2, \lambda_1 + \mu + 1; \frac{x}{x-1}) \end{aligned}$$

of the Gauss hypergeometric equation  $P_{\lambda_1, \lambda_2, \mu} u = 0$  with the Riemann scheme

$$(2.48) \quad \left\{ \begin{array}{ccc} x=0 & 1 & \infty \\ 0 & 0 & 1-\mu \\ \lambda_1 + \mu & \lambda_2 + \mu & -\lambda_1 - \lambda_2 - \mu \end{array} ; x \right\},$$

which is transformed by the middle convolution  $mc_\mu$  from the Riemann scheme

$$\left\{ \begin{array}{ccc} x=0 & 1 & \infty \\ \lambda_1 & \lambda_2 & -\lambda_1 - \lambda_2 \end{array} ; x \right\}$$

of  $x^{\lambda_1}(1-x)^{\lambda_2}$ . Here using Riemann's  $P$  symbol, we note that

$$\begin{aligned} & P \left\{ \begin{array}{ccc} x=0 & 1 & \infty \\ 0 & 0 & 1-\mu \\ \lambda_1 + \mu & \lambda_2 + \mu & -\lambda_1 - \lambda_2 - \mu \end{array} ; x \right\} \\ &= x^{\lambda_1 + \mu} P \left\{ \begin{array}{ccc} x=0 & 1 & \infty \\ -\lambda_1 - \mu & 0 & \lambda_1 + 1 \\ 0 & \lambda_2 + \mu & -\lambda_2 \end{array} ; x \right\} \\ &= x^{\lambda_1 + \mu} (1-x)^{\lambda_2 + \mu} P \left\{ \begin{array}{ccc} x=0 & 1 & \infty \\ -\lambda_1 - \mu & -\lambda_2 - \mu & \lambda_1 + \lambda_2 + \mu + 1 \\ 0 & 0 & \mu \end{array} ; x \right\} \\ &= x^{\lambda_1 + \mu} P \left\{ \begin{array}{ccc} x=0 & 1 & \infty \\ -\lambda_1 - \mu & \lambda_1 + 1 & 0 \\ 0 & -\lambda_2 & \lambda_2 + \mu \end{array} ; \frac{x}{x-1} \right\} \\ &= x^{\lambda_1 + \mu} (1-x)^{-\lambda_2} P \left\{ \begin{array}{ccc} x=0 & 1 & \infty \\ -\lambda_1 - \mu & \lambda_1 + \lambda_2 + 1 & -\lambda_2 \\ 0 & 0 & \mu \end{array} ; \frac{x}{x-1} \right\}. \end{aligned}$$

In general the Riemann scheme and its relation to  $mc_\mu$  will be studied in §6 and the symbol ' $P$ ' will be omitted for simplicity.

The function  $u(x)$  defined by (2.47) corresponds to the characteristic exponent  $\lambda_1 + \mu$  at the origin and depends meromorphically on the parameters  $\lambda_1, \lambda_2$  and  $\mu$ . The local solutions corresponding to the characteristic exponents  $\lambda_2 + \mu$  at 1 and  $-\lambda_1 - \lambda_2 - \mu$  at  $\infty$  are obtained by replacing  $I_0^\mu$  by  $I_1^\mu$  and  $I_\infty^\mu$ , respectively.

When we apply  $\text{Ad}(x^{\lambda'_1}(x-1)^{\lambda'_2})$  to  $P_{\lambda_1, \lambda_2, \mu}$ , the resulting Riemann scheme is

$$(2.49) \quad \left\{ \begin{array}{ccc} x=0 & 1 & \infty \\ \lambda'_1 & \lambda'_2 & 1 - \lambda'_1 - \lambda'_2 - \mu \\ \lambda_1 + \lambda'_1 + \mu & \lambda_2 + \lambda'_2 + \mu & -\lambda_1 - \lambda_2 - \lambda'_1 - \lambda'_2 - \mu \end{array} ; x \right\}.$$

Putting  $\lambda_{1,1} = \lambda'_1$ ,  $\lambda_{1,2} = \lambda_1 + \lambda'_1 + \mu$ ,  $\lambda_{2,1} = \lambda'_2$ ,  $\lambda_{2,2} = \lambda_2 + \lambda'_2 + \mu$ ,  $\lambda_{0,1} = 1 - \lambda'_1 - \lambda'_2 - \mu$  and  $\lambda_{0,2} = -\lambda_1 - \lambda_2 - \lambda'_1 - \lambda'_2 - \mu$ , we have the Fuchs relation

$$(2.50) \quad \lambda_{0,1} + \lambda_{0,2} + \lambda_{1,1} + \lambda_{1,2} + \lambda_{2,1} + \lambda_{2,2} = 1$$

and the corresponding operator

$$(2.51) \quad P_\lambda = x^2(x-1)^2\partial^2 + x(x-1)((\lambda_{0,1} + \lambda_{0,2} + 1)x + \lambda_{1,1} + \lambda_{1,2} - 1)\partial \\ + \lambda_{0,1}\lambda_{0,2}x^2 + (\lambda_{2,1}\lambda_{2,2} - \lambda_{0,1}\lambda_{0,2} - \lambda_{1,1}\lambda_{1,2})x + \lambda_{1,1}\lambda_{1,2}$$

has the Riemann scheme

$$(2.52) \quad \left\{ \begin{array}{ccc} x=0 & 1 & \infty \\ \lambda_{0,1} & \lambda_{1,1} & \lambda_{2,1} \\ \lambda_{0,2} & \lambda_{1,2} & \lambda_{2,2} \end{array} ; x \right\}.$$

By the symmetry of the transposition  $\lambda_{j,1}$  and  $\lambda_{j,2}$  for each  $j$ , we have integral representations of other local solutions.

ii) (Airy equations). For a positive integer  $m$  we put

$$(2.53) \quad \begin{aligned} P_m &:= L \circ \text{Ad}(e^{\frac{x^{m+1}}{m+1}}) \partial \\ &= L(\partial - x^m) = x - (-\partial)^m. \end{aligned}$$

Thus the equation

$$(2.54) \quad \frac{d^m u}{dx^m} - (-1)^m x u = 0$$

has a solution

$$(2.55) \quad u_j(x) = \int_{C_j} \exp\left(\frac{z^{m+1}}{m+1} - xz\right) dz \quad (0 \leq j \leq m),$$

where the path  $C_j$  of the integration is

$$C_j : z(t) = e^{\frac{(2j-1)\pi\sqrt{-1}}{m+1}-t} + e^{\frac{(2j+1)\pi\sqrt{-1}}{m+1}+t} \quad (-\infty < t < \infty).$$

Here we note that  $u_0(x) + \cdots + u_m(x) = 0$ . The equation has the symmetry under the rotation  $x \mapsto e^{\frac{2\pi\sqrt{-1}}{m+1}} x$ .

iii) (Jordan-Pochhammer equation). For  $\{c_1, \dots, c_p\} \in \mathbb{C} \setminus \{0\}$  put

$$\begin{aligned} P_{\lambda_1, \dots, \lambda_p, \mu} &:= \text{RAd}(\partial^{-\mu}) \circ \text{RAd}\left(\prod_{j=1}^p (1 - c_j x)^{\lambda_j}\right) \partial \\ &= \text{RAd}(\partial^{-\mu}) \circ \text{R}\left(\partial + \sum_{j=1}^p \frac{c_j \lambda_j}{1 - c_j x}\right) \\ &= \text{RAd}(\partial^{-\mu}) (p_0(x) \partial + q(x)) \\ &= \partial^{-\mu+p-1} (p_0(x) \partial + q(x)) \partial^\mu = \sum_{k=0}^p p_k(x) \partial^{p-k} \end{aligned}$$

with

$$\begin{aligned} p_0(x) &= \prod_{j=1}^p (1 - c_j x), \quad q(x) = p_0(x) \sum_{j=1}^p \frac{c_j \lambda_j}{1 - c_j x}, \\ p_k(x) &= \binom{-\mu + p - 1}{k} p_0^{(k)}(x) + \binom{-\mu + p - 1}{k-1} q^{(k-1)}(x), \\ \binom{\alpha}{\beta} &:= \frac{\Gamma(\alpha + 1)}{\Gamma(\beta + 1) \Gamma(\alpha - \beta + 1)} \quad (\alpha, \beta \in \mathbb{C}). \end{aligned}$$

We have solutions

$$u_j(x) = \frac{1}{\Gamma(\mu)} \int_{\frac{1}{c_j}}^x \prod_{\nu=1}^p (1 - c_\nu t)^{\lambda_\nu} (x-t)^{\mu-1} dt \quad (j = 0, 1, \dots, p, c_0 = 0)$$

of the Jordan-Pochhammer equation  $P_{\lambda_1, \dots, \lambda_p, \mu} u = 0$  with the Riemann scheme

$$(2.56) \quad \left\{ \begin{array}{ccccccc} x = \frac{1}{c_1} & \cdots & \frac{1}{c_p} & & \infty & & \\ [0]_{(p-1)} & \cdots & [0]_{(p-1)} & & [1-\mu]_{(p-1)} & & ; x \\ \lambda_1 + \mu & \cdots & \lambda_p + \mu & & -\lambda_1 - \cdots - \lambda_p - \mu & & \end{array} \right\}.$$

Here and hereafter we use the notation

$$(2.57) \quad [\lambda]_{(k)} := \begin{pmatrix} \lambda \\ \lambda + 1 \\ \vdots \\ \lambda + k - 1 \end{pmatrix}$$

for a complex number  $\lambda$  and a non-negative integer  $k$ . If the component  $[\lambda]_{(k)}$  is appeared in a Riemann scheme, it means the corresponding local solutions with the exponents  $\lambda + \nu$  for  $\nu = 0, \dots, k-1$  have a semisimple local monodromy when  $\lambda$  is generic.

**2.4. Ordinary differential equations.** We will study the ordinary differential equation

$$(2.58) \quad \mathcal{M} : Pu = 0$$

with an element  $P \in W(x; \xi)$  in this paper. The solution  $u(x, \xi)$  of  $\mathcal{M}$  is at least locally defined for  $x$  and  $\xi$  and holomorphically or meromorphically depends on  $x$  and  $\xi$ . Hence we may replace  $P$  by  $RP$  and we similarly choose  $P$  in  $W[x; \xi]$ .

We will identify  $\mathcal{M}$  with the left  $W(x; \xi)$ -module  $W(x; \xi)/W(x; \xi)P$ . Then we may consider (2.58) as the fundamental relation of the generator  $u$  of the module  $\mathcal{M}$ .

The results in this subsection are standard and well-known but for our convenience we briefly review them. First note that  $W(x; \xi)$  is a (left) Euclidean ring:

Let  $P, Q \in W(x; \xi)$  with  $P \neq 0$ . Then there uniquely exists  $R, S \in W(x; \xi)$  such that

$$(2.59) \quad Q = SP + R \quad (\text{ord } R < \text{ord } P).$$

Hence we note that  $\dim_{\mathbb{C}(x, \xi)}(W(x; \xi)/W(x; \xi)P) = \text{ord } P$ . We get  $R$  and  $S$  in (2.59) by a simple algorithm as follows. Put

$$(2.60) \quad P = a_n \partial^n + \dots + a_1 \partial + a_0 \quad \text{and} \quad Q = b_m \partial^m + \dots + b_1 \partial + b_0$$

with  $a_n \neq 0, b_m \neq 0$ . Here  $a_n, b_m \in \mathbb{C}(x, \xi)$ . The division (2.59) is obtained by the induction on  $\text{ord } Q$ . If  $\text{ord } P > \text{ord } Q$ , (2.59) is trivial with  $S = 0$ . If  $\text{ord } P \leq \text{ord } Q$ , (2.59) is reduced to the equality  $Q' = S'P + R$  with  $Q' = Q - a_n^{-1} b_m \partial^{m-n} P$  and  $S' = S - a_n^{-1} b_m \partial^{m-n}$  and then we have  $S'$  and  $R$  satisfying  $Q' = S'P + R$  by the induction because  $\text{ord } Q' < \text{ord } Q$ . The uniqueness of (2.59) is clear by comparing the highest order terms of (2.59) in the case when  $Q = 0$ .

By the standard Euclid algorithm using the division (2.59) we have  $M, N \in W(x; \xi)$  such that

$$(2.61) \quad MP + NQ = U, \quad P \in W(x; \xi)U \quad \text{and} \quad Q \in W(x; \xi)U.$$

Hence in particular any left ideal of  $W(x; \xi)$  is generated by a single element of  $W[x; \xi]$ , namely,  $W(x; \xi)$  is a principal ideal domain.

**Definition 2.9.** The operators  $P$  and  $Q$  in  $W(x; \xi)$  are defined to be *mutually prime* if one of the following equivalent conditions is valid.

$$(2.62) \quad W(x; \xi)P + W(x; \xi)Q = W(x; \xi),$$

$$(2.63) \quad \text{there exists } R \in W(x; \xi) \text{ satisfying } RQu = u \text{ for the equation } Pu = 0,$$

$$(2.64) \quad \left\{ \begin{array}{l} \text{the simultaneous equation } Pu = Qu = 0 \text{ has not a non-zero solution} \\ \text{for a generic value of } \xi. \end{array} \right.$$

Moreover we have the following.

$$(2.65) \quad \text{Any left } W(x; \xi)\text{-module } \mathcal{R} \text{ with } \dim_{\mathbb{C}(x, \xi)} \mathcal{R} < \infty \text{ is cyclic,}$$

namely, it is generated by a single element. Hence any system of ordinary differential equations is isomorphic to a single differential equation under the algebra  $W(x; \xi)$ .

To prove (2.65) it is sufficient to show that the direct sum  $\mathcal{M} \oplus \mathcal{N}$  of  $\mathcal{M} : Pu = 0$  and  $\mathcal{N} : Qv = 0$  is cyclic. In fact  $\mathcal{M} \oplus \mathcal{N} = W(x; \xi)w$  with  $w = u + (x - c)^n v \in \mathcal{M} \oplus \mathcal{N}$  and  $n = \text{ord } P$  if  $c \in \mathbb{C}$  is generic. For the proof we have only to show  $\dim_{\mathbb{C}(x, \xi)} W(x; \xi)w \geq m + n$  and we may assume that  $P$  and  $Q$  are in  $W[x; \xi]$

and they are of the form (2.60). Fix  $\xi$  generically and we choose  $c \in \mathbb{C}$  such that  $a_n(c)b_m(c) \neq 0$ . Since the function space  $V = \{\phi(x) + (x-c)^n\varphi(x); P\phi(x) = Q\varphi(x) = 0\}$  is of dimension  $m+n$  in a neighborhood of  $x = c$ ,  $\dim_{W(x;\xi)} W(x;\xi)w \geq m+n$  because the relation  $Rw = 0$  for an operator  $R \in W(x;\xi)$  implies  $R\psi(x) = 0$  for  $\psi \in V$ .

Thus we have the following standard definition.

**Definition 2.10.** Fix  $P \in W(x;\xi)$  with  $\text{ord } P > 0$ . The equation (2.58) is *irreducible* if and only if one of the following equivalent conditions is valid.

(2.66) The left  $W(x;\xi)$ -module  $\mathcal{M}$  is simple.

(2.67) The left  $W(x;\xi)$ -ideal  $W(x;\xi)P$  is maximal.

(2.68)  $P = QR$  with  $Q, R \in W(x;\xi)$  implies  $\text{ord } Q \cdot \text{ord } R = 0$ .

(2.69)  $\forall Q \notin W(x;\xi)P, \exists M, N \in W(x;\xi)$  satisfying  $MP + NQ = 1$ .

(2.70)  $\begin{cases} ST \in W(x;\xi)P \text{ with } S, T \in W(x;\xi) \text{ and } \text{ord } S < \text{ord } P \\ \Rightarrow S = 0 \text{ or } T \in W(x;\xi)P. \end{cases}$

The equivalence of the above conditions is standard and easily proved. The last condition may be a little non-trivial.

Suppose (2.70) and  $P = QR$  and  $\text{ord } Q \cdot \text{ord } R \neq 0$ . Then  $R \notin W(x;\xi)P$  and therefore  $Q = 0$ , which contradicts to  $P = QR$ . Hence (2.70) implies (2.68).

Suppose (2.66), (2.69),  $ST \in W(x;\xi)P$  and  $T \notin W(x;\xi)P$ . Then there exists  $P'$  such that  $\{J \in W(x;\xi); JT \in W(x;\xi)P\} = W(x;\xi)P'$ ,  $\text{ord } P' = \text{ord } P$  and moreover  $P'v = 0$  is also simple. Since  $Sv = 0$  with  $\text{ord } S < \text{ord } P'$ , we have  $S = 0$ .

In general a system of ordinary differential equations is defined to be irreducible if it is simple as a left  $W(x;\xi)$ -module.

*Remark 2.11.* Suppose the equation  $\mathcal{M}$  given in (2.58) is irreducible.

i) Let  $u(x,\xi)$  be a non-zero solution of  $\mathcal{M}$ , which is locally defined for the variables  $x$  and  $\xi$  and meromorphically depends on  $(x,\xi)$ . If  $S \in W[x;\xi]$  satisfies  $Su(x,\xi) = 0$ , then  $S \in W(x;\xi)P$ . Therefore  $u(x,\xi)$  determines  $\mathcal{M}$ .

ii) Suppose  $\text{ord } P > 1$ . Fix  $R \in W(x;\xi)$  such that  $\text{ord } R < \text{ord } P$  and  $R \neq 0$ . For  $Q \in W(x;\xi)$  and a positive integer  $m$ , the condition  $R^m Qu = 0$  is equivalent to  $Qu = 0$ . Hence for example, if  $Q_1 u + \partial^m Q_2 u = 0$  with certain  $Q_j \in W(x;\xi)$ , we will allow the expression  $\partial^{-m} Q_1 u + Q_2 u = 0$  and  $\partial^{-m} Q_1 u(x,\xi) + Q_2 u(x,\xi) = 0$ .

iii) For  $T \notin W(x;\xi)P$  we construct a differential equation  $Qv = 0$  satisfied by  $v = Tu$  as follows. Put  $n = \text{ord } P$ . We have  $R_j \in W(x;\xi)$  such that  $\partial^j Tu = R_j u$  with  $\text{ord } R_j < \text{ord } P$ . Then there exist  $b_0, \dots, b_n \in \mathbb{C}(x,\xi)$  such that  $b_n R_n + \dots + b_1 R_1 + b_0 R_0 = 0$ . Then  $Q = b_n \partial^n + \dots + b_1 \partial + b_0$ .

**2.5. Okubo normal form and Schlesinger canonical form.** In this subsection we briefly explain the interpretation of Katz's middle convolution (cf. [Kz]) by [DR] and its relation to our fractional operations.

For constant square matrices  $T$  and  $A$  of size  $n'$ , the ordinary differential equation

$$(2.71) \quad (xI_{n'} - T) \frac{du}{dx} = Au$$

is called *Okubo normal form* of Fuchsian system when  $T$  is a diagonal matrix. Then

$$(2.72) \quad mc_\mu((xI_{n'} - T)\partial - A) = (xI_{n'} - T)\partial - (A + \mu I_{n'})$$

for generic  $\mu \in \mathbb{C}$ , namely, the system is transformed into

$$(2.73) \quad (xI_{n'} - T) \frac{du_\mu}{dx} = (A + \mu I_{n'})u_\mu$$

by the operation  $mc_\mu$ . Hence for a solution  $u(x)$  of (2.71), the Euler transformation  $u_\mu(x) = I_c^\mu(u)$  of  $u(x)$  satisfies (2.73).

For constant square matrices  $A_j$  of size  $m$  and the Schlesinger canonical form

$$(2.74) \quad \frac{dv}{dx} = \sum_{j=1}^p \frac{A_j}{x-c_j} v$$

of a Fuchsian system of the Riemann sphere, we have

$$(2.75) \quad \frac{du}{dx} = \sum_{j=1}^p \frac{\tilde{A}_j}{x-c_j} u, \quad \tilde{A}_j := j \begin{pmatrix} A_1 & \cdots & A_p \end{pmatrix} \quad \text{and} \quad u := \begin{pmatrix} \frac{v}{x-c_1} \\ \vdots \\ \frac{v}{x-c_p} \end{pmatrix}.$$

Here  $\tilde{A}_j$  are square matrices of size  $pm$ . The addition  $\text{Ad}((x-c_k)^{\mu_k})$  transforms  $A_j$  into  $A_j + \mu_k \delta_{j,k} I_m$  for  $j = 1, \dots, p$  in the system (2.74). Putting

$$A = \tilde{A}_1 + \cdots + \tilde{A}_p \quad \text{and} \quad T = \begin{pmatrix} c_1 I_m & & \\ & \ddots & \\ & & c_p I_m \end{pmatrix},$$

the equation (2.75) is equivalent to (2.71) with  $n' = pm$ . Define square matrices of size  $n'$  by

$$(2.76) \quad \tilde{A} := \begin{pmatrix} A_1 & & \\ & \ddots & \\ & & A_p \end{pmatrix},$$

$$(2.77) \quad \tilde{A}_j(\mu) := j \begin{pmatrix} & & & \overset{j}{\underbrace{}} & & \\ A_1 & \cdots & A_{j-1} & A_j + \mu & A_{j+1} & \cdots & A_p \end{pmatrix}.$$

Then  $\ker \tilde{A}$  and  $\ker(A + \mu)$  are invariant under  $\tilde{A}_j(\mu)$  for  $j = 1, \dots, p$  and therefore  $\tilde{A}_j(\mu)$  induce endomorphisms of  $V := \mathbb{C}^{pm}/(\ker \tilde{A} + \ker(A + \mu))$ , which correspond to square matrices of size  $N := \dim V$ , which we put  $\bar{A}_j(\mu)$ , respectively, under a fixed basis of  $V$ . Then the middle convolution  $mc_\mu$  of (2.74) is the system

$$(2.78) \quad \frac{dw}{dx} = \sum_{j=1}^p \frac{\bar{A}_j(\mu)}{x-c_j} w$$

of rank  $N$ , which is defined and studied by [DR, DR2]. Here  $\ker \tilde{A} \cap \ker(A + \mu) = \{0\}$  if  $\mu \neq 0$ .

We define another realization of the middle convolution as in [O5, §2]. Suppose  $\mu \neq 0$ . The square matrices of size  $n'$

$$(2.79) \quad A_j^\vee(\mu) := j \begin{pmatrix} & \overset{j}{\underbrace{}} & \\ & A_1 & \\ & \vdots & \\ & A_j + \mu & \\ & \vdots & \\ & A_p & \end{pmatrix} \quad \text{and} \quad A^\vee(\mu) := A_1^\vee(\mu) + \cdots + A_p^\vee(\mu)$$

satisfy

$$(2.80) \quad \tilde{A}(A + \mu I_{n'}) = A^\vee(\mu) \tilde{A} = \left( A_i A_j + \mu \delta_{i,j} A_i \right)_{\substack{1 \leq i \leq p \\ 1 \leq j \leq p}} \in M(n', \mathbb{C}),$$

$$(2.81) \quad \tilde{A}(A + \mu I_{n'}) \tilde{A}_j(\mu) = A_j^\vee(\mu) \tilde{A}(A + \mu I_{n'}).$$

Hence  $w^\vee := \tilde{A}(A + \mu I_{n'})u$  satisfies

$$(2.82) \quad \frac{dw^\vee}{dx} = \sum_{j=1}^p \frac{A_j^\vee(\mu)}{x - c_j} w^\vee,$$

$$\sum_{j=1}^p \frac{A_j^\vee(\mu)}{x - c_j} = \left( \frac{A_i + \mu \delta_{i,j} I_m}{x - c_j} \right)_{\substack{1 \leq i \leq p \\ 1 \leq j \leq p}}$$

and  $\tilde{A}(A + \mu I_{n'})$  induces the isomorphism

$$(2.83) \quad \tilde{A}(A + \mu I_{n'}) : V = \mathbb{C}^{n'} / (\mathcal{K} + \mathcal{L}_\mu) \xrightarrow{\sim} V^\vee := \text{Im } \tilde{A}(A + \mu I_{n'}) \subset \mathbb{C}^{n'}.$$

Hence putting  $\bar{A}_j^\vee(\mu) := A_j^\vee(\mu)|_{V^\vee}$ , the system (2.78) is isomorphic to the system

$$(2.84) \quad \frac{dw^\vee}{dx} = \sum_{j=1}^p \frac{\bar{A}_j^\vee(\mu)}{x - c_j} w^\vee$$

of rank  $N$ , which can be regarded as a middle convolution  $mc_\mu$  of (2.74). Here

$$(2.85) \quad w^\vee = \begin{pmatrix} w_1^\vee \\ \vdots \\ w_p^\vee \end{pmatrix}, \quad w_j^\vee = \sum_{\nu=1}^p (A_j A_\nu + \mu \delta_{j,\nu})(u_\mu)_\nu \quad (j = 1, \dots, p)$$

and if  $v(x)$  is a solution of (2.74), then

$$(2.86) \quad w^\vee(x) = \left( \sum_{\nu=1}^p (A_j A_\nu + \mu \delta_{j,\nu}) I_c^\mu \left( \frac{v(x)}{x - c_\nu} \right) \right)_{j=1, \dots, p}$$

satisfies (2.84).

Since any non-zero homomorphism between irreducible  $W(x)$ -modules is an isomorphism, we have the following remark (cf. §2.4 and §5).

*Remark 2.12.* Suppose that the systems (2.74) and (2.84) are irreducible. Moreover suppose the system (2.74) is isomorphic to a single Fuchsian differential equation  $P\tilde{u} = 0$  as left  $W(x)$ -modules and the equation  $mc_\mu(P)\tilde{w} = 0$  is also irreducible. Then the system (2.84) is isomorphic to the single equation  $mc_\mu(P)\tilde{w} = 0$  because the differential equation satisfied by  $I_c^\mu(\tilde{u}(x))$  is isomorphic to that of  $I_c^\mu(Q\tilde{u}(x))$  for a non-zero solution  $v(x)$  of  $P\tilde{u} = 0$  and an operator  $Q \in W(x)$  with  $Q\tilde{u}(x) \neq 0$  (cf. §5, Remark 7.4 iii) and Proposition 8.12).

In particular if the systems are rigid and their spectral parameters are generic, all the assumptions here are satisfied (cf. Remark 6.17 ii) and Corollary 12.12).

Yokoyama [Yo2] defines extension and restriction operations among the systems of differential equations of Okubo normal form. The relation of Yokoyama's operations to Katz's operations is clarified by [O7], which shows that they are equivalent from the view point of the construction and the reduction of systems of Fuchsian differential equations.

### 3. CONFLUENCES

**3.1. Regular singularities.** In this subsection we review fundamental facts related to the regular singularities of the ordinary differential equations.



3.1.1. *Characteristic exponents.* The ordinary differential equation

$$(3.1) \quad a_n(x) \frac{d^n u}{dx^n} + a_{n-1}(x) \frac{d^{n-1} u}{dx^{n-1}} + \cdots + a_1(x) \frac{du}{dx} + a_0(x)u = 0$$

of order  $n$  with meromorphic functions  $a_j(x)$  defined in a neighborhood of  $c \in \mathbb{C}$  has a singularity at  $x = c$  if the function  $\frac{a_j(x)}{a_n(x)}$  has a pole at  $x = c$  for a certain  $j$ . The singular point  $x = c$  of the equation is a *regular singularity* if it is a removable singularity of the functions  $b_j(x) := (x - c)^{n-j} a_j(x) a_n(x)^{-1}$  for  $j = 0, \dots, n$ . In this case  $b_j(c)$  are complex numbers and the  $n$  roots of the *indicial equation*

$$(3.2) \quad \sum_{j=0}^n b_j(c) s(s-1) \cdots (s-j+1) = 0$$

are called the *characteristic exponents* of (3.1) at  $c$ .

Let  $\{\lambda_1, \dots, \lambda_n\}$  be the set of these characteristic exponents at  $c$ .

If  $\lambda_j - \lambda_1 \notin \mathbb{Z}_{>0}$  for  $1 < j \leq n$ , then (3.1) has a unique solution  $(x - c)^{\lambda_1} \phi_1(x)$  with a holomorphic function  $\phi_1(x)$  in a neighborhood of  $c$  satisfying  $\phi_1(c) = 1$ .

**Definition 3.1.** The regular singularity and the characteristic exponents for the differential operator

$$(3.3) \quad P = a_n(x) \frac{d^n}{dx^n} + a_{n-1}(x) \frac{d^{n-1}}{dx^{n-1}} + \cdots + a_1(x) \frac{d}{dx} + a_0(x)$$

are defined by those of the equation (3.1), respectively. Suppose  $P$  has a regular singularity at  $c$ . We say  $P$  is *normalized at  $c$*  if  $a_n(x)$  is holomorphic at  $c$  and

$$(3.4) \quad a_n(c) = a_n^{(1)}(c) = \cdots = a_n^{(n-1)}(c) = 0 \quad \text{and} \quad a_n^{(n)}(c) \neq 0.$$

In this case  $a_j(x)$  are analytic and have zeros of order at least  $j$  at  $x = c$  for  $j = 0, \dots, n-1$ .

3.1.2. *Local solutions.* The ring of convergent power series at  $x = c$  is denoted by  $\mathcal{O}_c$  and for a complex number  $\mu$  and a non-negative integer  $m$  we put

$$(3.5) \quad \mathcal{O}_c(\mu, m) := \bigoplus_{\nu=0}^m (x - c)^\mu \log^\nu(x - c) \mathcal{O}_c.$$

Let  $P$  be a differential operator of order  $n$  which has a regular singularity at  $x = c$  and let  $\{\lambda_1, \dots, \lambda_n\}$  be the corresponding characteristic exponents. Suppose  $P$  is normalized at  $c$ . If a complex number  $\mu$  satisfies  $\lambda_j - \mu \notin \{0, 1, 2, \dots\}$  for  $j = 1, \dots, n$ , then  $P$  defines a linear bijective map

$$(3.6) \quad P : \mathcal{O}_c(\mu, m) \xrightarrow{\sim} \mathcal{O}_c(\mu, m)$$

for any non-negative integer  $m$ .

Let  $\hat{\mathcal{O}}_c$  be the ring of formal power series  $\sum_{j=0}^{\infty} a_j(x - c)^j$  ( $a_j \in \mathbb{C}$ ) of  $x$  at  $c$ . For a domain  $U$  of  $\mathbb{C}$  we denote by  $\mathcal{O}(U)$  the ring of holomorphic functions on  $U$ . Put

$$(3.7) \quad B_r(c) := \{x \in \mathbb{C}; |x - c| < r\}$$

for  $r > 0$  and

$$(3.8) \quad \hat{\mathcal{O}}_c(\mu, m) := \bigoplus_{\nu=0}^m (x - c)^\mu \log^\nu(x - c) \hat{\mathcal{O}}_c,$$

$$(3.9) \quad \mathcal{O}_{B_r(c)}(\mu, m) := \bigoplus_{\nu=0}^m (x - c)^\mu \log^\nu(x - c) \mathcal{O}_{B_r(c)}.$$

Then  $\mathcal{O}_{B_r(c)}(\mu, m) \subset \mathcal{O}_c(\mu, m) \subset \hat{\mathcal{O}}_c(\mu, m)$ .

Suppose  $a_j(x) \in \mathcal{O}(B_r(c))$  and  $a_n(x) \neq 0$  for  $x \in B_r(c) \setminus \{c\}$  and moreover  $\lambda_j - \mu \notin \{0, 1, 2, \dots\}$ , we have

$$(3.10) \quad P : \mathcal{O}_{B_r(c)}(\mu, m) \xrightarrow{\sim} \mathcal{O}_{B_r(c)}(\mu, m),$$

$$(3.11) \quad P : \hat{\mathcal{O}}_c(\mu, m) \xrightarrow{\sim} \hat{\mathcal{O}}_c(\mu, m).$$

The proof of these results are reduced to the case when  $\mu = m = c = 0$  by the translation  $x \mapsto x - c$ , the operation  $\text{Ad}(x^{-\mu})$ , and the fact  $P(\sum_{j=0}^m f_j(x) \log^j x) = (Pf_m(x)) \log^j x + \sum_{j=0}^{m-1} \phi_j(x) \log^j x$  with suitable  $\phi_j(x)$  and moreover we may assume

$$P = \prod_{j=0}^n (\vartheta - \lambda_j) - xR(x, \vartheta),$$

$$xR(x, \vartheta) = x \sum_{j=0}^{n-1} r_j(x) \vartheta^j \quad (r_j(x) \in \mathcal{O}(B_r(c))).$$

When  $\mu = m = 0$ , (3.11) is easy and (3.10) and hence (3.6) are also easily proved by the method of majorant series (for example, cf. [O1]).

For the differential operator

$$Q = \frac{d^n}{dx^n} + b_{n-1}(x) \frac{d^{n-1}}{dx^{n-1}} + \dots + b_1(x) \frac{d}{dx} + b_0(x)$$

with  $b_j(x) \in \mathcal{O}(B_r(c))$ , we have a bijection

$$(3.12) \quad \begin{array}{ccc} Q : \mathcal{O}(B_r(c)) & \xrightarrow{\sim} & \mathcal{O}(B_r(c)) \oplus \mathbb{C}^n \\ \downarrow \Psi & & \downarrow \Psi \\ u(x) & \mapsto & Pu(x) \oplus (u^{(j)}(c))_{0 \leq j \leq n-1} \end{array}$$

because  $Q(x-c)^n$  has a regular singularity at  $x = c$  and the characteristic exponents are  $-1, -2, \dots, -n$  and hence (3.10) assures that for any  $g(x) \in \mathbb{C}[x]$  and  $f(x) \in \mathcal{O}(B_r(c))$  there uniquely exists  $v(x) \in \mathcal{O}(B_r(c))$  such that  $Q(x-c)^n v(x) = f(x) - Qg(x)$ .

If  $\lambda_\nu - \lambda_1 \notin \mathbb{Z}_{>0}$ , the characteristic exponents of  $R := \text{Ad}((x-c)^{-\lambda_1-1})P$  at  $x = c$  are  $\lambda_\nu - \lambda_1 - 1$  for  $\nu = 1, \dots, n$  and therefore  $R = S(x-c)$  with a differential operator  $R$  whose coefficients are in  $\mathcal{O}(B_r(c))$ . Then there exists  $v_1(x) \in \mathcal{O}(B_r(c))$  such that  $-S1 = S(x-c)v_1(x)$ , which means  $P((x-c)^{\lambda_1}(1 + (x-c)v_1(x))) = 0$ . Hence if  $\lambda_i - \lambda_j \notin \mathbb{Z}$  for  $1 \leq i < j \leq n$ , we have solutions  $u_\nu(x)$  of  $Pu = 0$  such that

$$(3.13) \quad u_\nu(x) = (x-c)^{\lambda_\nu} \phi_\nu(x)$$

with suitable  $\phi_\nu \in \mathcal{O}(B_r(c))$  satisfying  $\phi_\nu(c) = 1$  for  $\nu = 1, \dots, n$ .

Put  $k = \#\{\nu; \lambda_\nu = \lambda_1\}$  and  $m = \#\{\nu; \lambda_\nu - \lambda_1 \in \mathbb{Z}_{\geq 0}\}$ . Then we have solutions  $u_\nu(x)$  of  $Pu = 0$  for  $\nu = 1, \dots, k$  such that

$$(3.14) \quad u_\nu(x) - (x-c)^{\lambda_1} \log^{\nu-1}(x-c) \in \mathcal{O}_{B_r(c)}(\lambda_1 + 1, m-1).$$

If  $\mathcal{O}_{B_r(c)}$  is replaced by  $\hat{\mathcal{O}}_c$ , the solution

$$u_\nu(x) = (x-c)^{\lambda_1} \log^{\nu-1}(x-c) + \sum_{i=1}^{\infty} \sum_{j=0}^{m-1} c_{\nu,i,j} (x-c)^{\lambda_1+i} \log^j(x-c) \in \hat{\mathcal{O}}_c(\lambda_1, m-1)$$

is constructed by inductively defining  $c_{\nu,i,j} \in \mathbb{C}$ . Since

$$P \left( \sum_{i=N+1}^{\infty} \sum_{j=0}^{m-1} c_{\nu,i,j} (x-c)^{\lambda_1+i} \log^j(x-c) \right) = -P \left( (x-c)^{\lambda_1} \log^{\nu-1}(x-c) \right) \\ + \sum_{i=1}^N c_{\nu,i,j} (x-c)^{\lambda_1+i} \log^j(x-c) \in \mathcal{O}_{B_r(c)}(\lambda_1 + N, m-1)$$

for an integer  $N$  satisfying  $\operatorname{Re}(\lambda_\ell - \lambda_1) < N$  for  $\ell = 1, \dots, n$ , we have

$$\sum_{i=N+1}^{\infty} \sum_{j=0}^{m-1} c_{\nu,i,j} (x-c)^{\lambda_1+i} \log^j(x-c) \in \mathcal{O}_{B_r(c)}(\lambda_1 + N, m-1)$$

because of (3.10) and (3.11), which means  $u_\nu(x) \in \mathcal{O}_{B_r(c)}(\lambda_1, m)$ .

**3.1.3. Fuchsian differential equations.** The regular singularity at  $\infty$  is similarly defined by that at the origin under the coordinate transformation  $x \mapsto \frac{1}{x}$ . When  $P \in W(x)$  and the singular points of  $P$  in  $\overline{\mathbb{C}} := \mathbb{C} \cup \{\infty\}$  are all regular singularities, the operator  $P$  and the equation  $Pu = 0$  are called *Fuchsian*. Let  $\overline{\mathbb{C}}'$  be the subset of  $\overline{\mathbb{C}}$  deleting singular points  $c_0, \dots, c_p$  from  $\overline{\mathbb{C}}$ . Then the solutions of the equation  $Pu = 0$  defines a map

$$(3.15) \quad \mathcal{F} : \overline{\mathbb{C}}' \supset U : (\text{simply connected domain}) \mapsto \mathcal{F}(U) \subset \mathcal{O}(U)$$

by putting  $\mathcal{F}(U) := \{u(x) \in \mathcal{O}(U) ; Pu(x) = 0\}$ . Put

$$U_{j,\epsilon,R} = \begin{cases} \{x = c_j + re^{\sqrt{-1}\theta} ; 0 < r < \epsilon, R < \theta < R + 2\pi\} & (c_j \neq \infty) \\ \{x = re^{\sqrt{-1}\theta} ; r > \epsilon^{-1}, R < \theta < R + 2\pi\} & (c_j = \infty). \end{cases}$$

For simply connected domains  $U, V \subset \overline{\mathbb{C}}'$ , the map  $\mathcal{F}$  satisfies

$$(3.16) \quad \mathcal{F}(U) \subset \mathcal{O}(U) \quad \text{and} \quad \dim \mathcal{F}(U) = n,$$

$$(3.17) \quad V \subset U \Rightarrow \mathcal{F}(V) = \mathcal{F}(U)|_V,$$

$$(3.18) \quad \begin{cases} \exists \epsilon > 0, \forall \phi \in \mathcal{F}(U_{j,\epsilon,R}), \exists C > 0, \exists m > 0 \text{ such that} \\ |\phi(x)| < \begin{cases} C|x - c_j|^{-m} & (c_j \neq \infty, x \in U_{j,\epsilon,R}), \\ C|x|^m & (c_j = \infty, x \in U_{j,\epsilon,R}) \end{cases} \\ \text{for } j = 0, \dots, p, \forall R \in \mathbb{R}. \end{cases}$$

Then we have the bijection

$$(3.19) \quad \left\{ \partial^n + \sum_{j=0}^{n-1} a_j(x) \partial^j \in W(x) : \text{Fuchsian} \right\} \xrightarrow{\sim} \left\{ \mathcal{F} \text{ satisfying (3.16)–(3.18)} \right\} \\ \begin{array}{ccc} & \Psi & \\ & P & \\ & \mapsto & \{U \mapsto \{u \in \mathcal{O}(U) ; Pu = 0\}\}. \end{array}$$

Here if  $\mathcal{F}(U) = \sum_{j=1}^n \mathbb{C} \phi_j(x)$ ,

$$(3.20) \quad a_j(x) = (-1)^{n-j} \frac{\det \Phi_j}{\det \Phi_n} \quad \text{with} \quad \Phi_j = \begin{pmatrix} \phi_1^{(0)}(x) & \cdots & \phi_n^{(0)}(x) \\ \vdots & \vdots & \vdots \\ \phi_1^{(j-1)}(x) & \cdots & \phi_n^{(j-1)}(x) \\ \phi_1^{(j+1)}(x) & \cdots & \phi_n^{(j+1)}(x) \\ \vdots & \vdots & \vdots \\ \phi_1^{(n)}(x) & \cdots & \phi_n^{(n)}(x) \end{pmatrix}.$$

The elements  $\mathcal{F}_1$  and  $\mathcal{F}_2$  of the right hand side of (3.19) are naturally identified if there exists a simply connected domain  $U$  such that  $\mathcal{F}_1(U) = \mathcal{F}_2(U)$ .

Let

$$P = \partial^n + a_{n-1}(x)\partial^{n-1} + \cdots + a_0(x)$$

be a Fuchsian differential operator with  $p+1$  regular singular points  $c_0 = \infty, c_1, \dots, c_p$  and let  $\lambda_{j,1}, \dots, \lambda_{j,n}$  be the characteristic exponents of  $P$  at  $c_j$ , respectively. Since  $a_{n-1}(x)$  is holomorphic at  $x = \infty$  and  $a_{n-1}(\infty) = 0$ , there exists  $a_{n-1,j} \in \mathbb{C}$  such that  $a_{n-1}(x) = -\sum_{j=1}^p \frac{a_{n-1,j}}{x-c_j}$ . For  $c \in \mathbb{C}$  we have  $x^n(\partial^n - cx^{-1}\partial^{n-1}) = \vartheta^n - (c + \frac{n(n-1)}{2})\vartheta^{n-1} + c_{n-2}\vartheta^{n-2} + \cdots + c_0$  with  $c_j \in \mathbb{C}$ . Hence we have

$$\lambda_{j,1} + \cdots + \lambda_{j,n} = \begin{cases} -\sum_{j=1}^p a_{n-1,j} - \frac{n(n-1)}{2} & (j = 0), \\ a_{n-1,j} + \frac{n(n-1)}{2} & (j = 1, \dots, p), \end{cases}$$

and the *Fuchs relation*

$$(3.21) \quad \sum_{j=0}^p \sum_{\nu=1}^n \lambda_{j,\nu} = \frac{(p-1)n(n-1)}{2}.$$

Suppose  $Pu = 0$  is reducible. Then  $P = SR$  with  $S, R \in W(x)$  so that  $n' = \text{ord } R < n$ . Since the solution  $v(x)$  of  $Rv = 0$  satisfies  $Pv(x) = 0$ ,  $R$  is also Fuchsian. Note that the set of  $m$  characteristic exponents  $\{\lambda'_{j,\nu}; \nu = 1, \dots, n'\}$  of  $Rv = 0$  at  $c_j$  is a subset of  $\{\lambda_{j,\nu}; \nu = 1, \dots, n\}$ . The operator  $R$  may have other singular points  $c'_1, \dots, c'_q$  called *apparent singular points* where any local solutions at the points is analytic. Hence the set characteristic exponents at  $x = c'_j$  are  $\{\lambda'_{j,\nu} \nu = 1, \dots, n'\}$  such that  $0 \leq \mu_{j,1} < \mu_{j,2} < \cdots < \mu_{j,n'}$  and  $\mu_{j,\nu} \in \mathbb{Z}$  for  $\nu = 1, \dots, n'$  and  $j = 1, \dots, q$ . Since  $\mu_{j,1} + \cdots + \mu_{j,n'} \geq \frac{n'(n'-1)}{2}$ , the Fuchs relation for  $R$  implies

$$(3.22) \quad \mathbb{Z} \ni \sum_{j=0}^p \sum_{\nu=1}^{n'} \lambda'_{j,\nu} \leq \frac{(p-1)n'(n'-1)}{2}.$$

Fixing a generic point  $q$  and paths  $\gamma_j$  around  $c_j$  as in (11.25) and moreover a base  $\{u_1, \dots, u_n\}$  of local solutions of the equation  $Pu = 0$  at  $q$ , we can define monodromy generators  $M_j \in GL(n, \mathbb{C})$ . We call the tuple  $\mathbf{M} = (M_0, \dots, M_p)$  the *monodromy* of the equation  $Pu = 0$ . The monodromy  $\mathbf{M}$  is defined to be *irreducible* if there exists no subspace  $V$  of  $\mathbb{C}^n$  such that  $M_j V \subset V_j$  for  $j = 0, \dots, p$  and  $0 < \dim V < n$ , which is equivalent to the condition that  $P$  is irreducible.

Suppose  $Qv = 0$  is another Fuchsian differential equation of order  $n$  with the same singular points. The monodromy  $\mathbf{N} = (N_0, \dots, N_p)$  is similarly defined by fixing a base  $\{v_1, \dots, v_n\}$  of local solutions of  $Qv = 0$  at  $q$ . Then

$$(3.23) \quad \begin{aligned} \mathbf{M} \sim \mathbf{N} &\stackrel{\text{def}}{\Leftrightarrow} \exists g \in GL(n, \mathbb{C}) \text{ such that } N_j = gM_jg^{-1} \ (j = 0, \dots, p) \\ &\Leftrightarrow Qv = 0 \text{ is } W(x)\text{-isomorphic to } Pu = 0. \end{aligned}$$

If  $Qv = 0$  is  $W(x)$ -isomorphic to  $Pu = 0$ , the isomorphism defines an isomorphism between their solutions and then  $N_j = M_j$  under the bases corresponding to the isomorphism.

Suppose there exists  $g \in GL(n, \mathbb{C})$  such that  $N_j = gM_jg^{-1}$  for  $j = 0, \dots, p$ . The equations  $Pu = 0$  and  $Qu = 0$  are  $W(x)$ -isomorphic to certain first order systems  $U' = A(x)U$  and  $V' = B(x)V$  of rank  $n$ , respectively. We can choose bases  $\{U_1, \dots, U_n\}$  and  $\{V_1, \dots, V_n\}$  of local solutions of  $PU = 0$  and  $QV = 0$  at  $q$ , respectively, such that their monodromy generators corresponding  $\gamma_j$  are same for each  $j$ . Put  $\tilde{U} = (U_1, \dots, U_n)$  and  $\tilde{V} = (V_1, \dots, V_n)$ . Then the element of the matrix  $\tilde{V}\tilde{U}^{-1}$  is holomorphic at  $q$  and can be extended to a rational function of  $x$

and then  $\tilde{V}\tilde{U}^{-1}$  defines a  $W(x)$ -isomorphism between the equations  $U' = A(x)U$  and  $V' = B(x)V$ .

**Example 3.2** (Apparent singularity). The differential equation

$$(3.24) \quad x(x-1)(x-c)\frac{dy^2}{dx} + (x^2 - 2cx + c)\frac{dy}{dx} = 0$$

is a special case of Heun's equation (8.19) with  $\alpha = \beta = \lambda = 0$  and  $\gamma = \delta = 1$ . It has regular singularities at  $0, 1, c$  and  $\infty$  and its Riemann scheme equals

$$(3.25) \quad \left\{ \begin{array}{cccc} x = \infty & 0 & 1 & c \\ & 0 & 0 & 0 \\ & 0 & 0 & 2 \end{array} \right\}.$$

The local solution at  $x = c$  corresponding to the characteristic exponent  $0$  is holomorphic at the point and therefore  $x = c$  is an apparent singularity, which corresponds to the zero of the Wronskian  $\det \Phi_n$  in (3.20). Note that the equation (3.24) has the solutions  $1$  and  $c \log x + (1-c) \log(x-1)$ .

The equation (3.24) is not  $W(x)$ -isomorphic to Gauss hypergeometric equation if  $c \neq 0$  and  $c \neq 1$ , which follows from the fact that  $c$  is a modulus of the isomorphic classes of the monodromy. It is easy to show that any tuple of matrices  $\mathbf{M} = (M_0, M_1, M_2) \in GL(2, \mathbb{C})$  satisfying  $M_2 M_1 M_0 = I_2$  is realized as the monodromy of the equation obtained by applying a suitable addition  $\text{RAd}(x^{\lambda_0}(1-x)^{\lambda_1})$  to a certain Gauss hypergeometric equation or the above equation.

**3.2. A confluence.** The non-trivial equation  $(x-a)\frac{du}{dx} = \mu u$  obtained by the addition  $\text{RAd}((x-a)^\mu)\partial$  has a solution  $(x-a)^\mu$  and regular singularities at  $x = c$  and  $\infty$ . To consider the confluence of the point  $x = a$  to  $\infty$  we put  $a = \frac{1}{c}$ . Then the equation is

$$((1-cx)\partial + c\mu)u = 0$$

and it has a solution  $u(x) = (1-cx)^\mu$ .

The substitution  $c = 0$  for the operator  $(1-cx)\partial + c\mu \in W[x; c, \mu]$  gives the trivial equation  $\frac{du}{dx} = 0$  with the trivial solution  $u(x) \equiv 1$ . To obtain a nontrivial equation we introduce the parameter  $\lambda = c\mu$  and we have the equation

$$((1-cx)\partial + \lambda)u = 0$$

with the solution  $(1-cx)^{\frac{\lambda}{c}}$ . The function  $(1-cx)^{\frac{\lambda}{c}}$  has the holomorphic parameters  $c$  and  $\lambda$  and the substitution  $c = 0$  gives the equation  $(\partial + \lambda)u = 0$  with the solution  $e^{-\lambda x}$ . Here  $(1-cx)\partial + \lambda = \text{RAd}(\frac{\lambda}{1-cx})\partial = \text{RAd}((1-cx)^{\frac{\lambda}{c}})\partial$ .

This is the simplest example of the confluence and we define a confluence of simultaneous additions in this subsection.

**3.3. Versal additions.** For a function  $h(c, x)$  with a holomorphic parameter  $c \in \mathbb{C}$  we put

$$(3.26) \quad \begin{aligned} h_n(c_1, \dots, c_n, x) &:= \frac{1}{2\pi\sqrt{-1}} \int_{|z|=R} \frac{h(z, x) dz}{\prod_{j=1}^n (z - c_j)} \\ &= \sum_{k=1}^n \frac{h(c_k, x)}{\prod_{1 \leq i \leq n, i \neq k} (c_k - c_i)} \end{aligned}$$

with a sufficiently large  $R > 0$ . Put

$$(3.27) \quad h(c, x) := c^{-1} \log(1-cx) = -x - \frac{c}{2}x^2 - \frac{c^2}{3}x^3 - \frac{c^3}{4}x^4 - \dots$$

Then

$$(3.28) \quad (1-cx)h'(c, x) = -1$$

and

$$(3.29) \quad h'_n(c_1, \dots, c_n, x) \prod_{1 \leq i \leq n} (1 - c_i x) = - \sum_{k=1}^n \frac{\prod_{1 \leq i \leq n, i \neq k} (1 - c_i x)}{\prod_{1 \leq i \leq n, i \neq k} (c_k - c_i)} = -x^{n-1}.$$

The last equality in the above is obtained as follows. Since the left hand side of (3.29) is a holomorphic function of  $(c_1, \dots, c_n) \in \mathbb{C}^n$  and the coefficient of  $x^m$  is homogeneous of degree  $m - n + 1$ , it is zero if  $m < n - 1$ . The coefficient of  $x^{n-1}$  proved to be  $-1$  by putting  $c_1 = 0$ . Thus we have

$$(3.30) \quad h_n(c_1, \dots, c_n, x) = - \int_0^x \frac{t^{n-1} dt}{\prod_{1 \leq i \leq n} (1 - c_i t)},$$

$$(3.31) \quad e^{\lambda_n h_n(c_1, \dots, c_n, x)} \circ \left( \prod_{1 \leq i \leq n} (1 - c_i x) \right) \partial \circ e^{-\lambda_n h_n(c_1, \dots, c_n, x)} = \left( \prod_{1 \leq i \leq n} (1 - c_i x) \right) \partial + \lambda_n x^{n-1},$$

$$(3.32) \quad e^{\lambda_n h_n(c_1, \dots, c_n, x)} = \prod_{k=1}^n (1 - c_k x)^{\frac{\lambda_n}{c_k \prod_{1 \leq i \leq n, i \neq k} (c_k - c_i)}}.$$

**Definition 3.3** (Versal addition). We put

$$(3.33) \quad \text{AdV}_{(\frac{1}{c_1}, \dots, \frac{1}{c_p})}(\lambda_1, \dots, \lambda_p) := \text{Ad} \left( \prod_{k=1}^p (1 - c_k x)^{\frac{\sum_{n=k}^p \lambda_n}{c_k \prod_{1 \leq i \leq n, i \neq k} (c_k - c_i)}} \right) = \text{Adei} \left( - \sum_{n=1}^p \frac{\lambda_n x^{n-1}}{\prod_{i=1}^n (1 - c_i x)} \right),$$

$$(3.34) \quad \text{RAdV}_{(\frac{1}{c_1}, \dots, \frac{1}{c_p})}(\lambda_1, \dots, \lambda_p) = \text{R} \circ \text{AdV}_{(\frac{1}{c_1}, \dots, \frac{1}{c_p})}(\lambda_1, \dots, \lambda_p).$$

We call  $\text{RAdV}_{(\frac{1}{c_1}, \dots, \frac{1}{c_p})}(\lambda_1, \dots, \lambda_p)$  a *versal addition* at the  $p$  points  $\frac{1}{c_1}, \dots, \frac{1}{c_p}$ .

Putting

$$h(c, x) := \log(x - c),$$

we have

$$h'_n(c_1, \dots, c_n, x) \prod_{1 \leq i \leq n} (x - c_i) = \sum_{k=1}^n \frac{\prod_{1 \leq i \leq n, i \neq k} (x - c_i)}{\prod_{1 \leq i \leq n, i \neq k} (c_k - c_i)} = 1$$

and the *confluence of additions around the origin* is defined by

$$(3.35) \quad \text{AdV}_{(a_1, \dots, a_p)}^0(\lambda_1, \dots, \lambda_p) := \text{Ad} \left( \prod_{k=1}^p (x - a_k)^{\frac{\sum_{n=k}^p \lambda_n}{\prod_{1 \leq i \leq n, i \neq k} (a_k - a_i)}} \right) = \text{Adei} \left( \sum_{n=1}^p \frac{\lambda_n}{\prod_{1 \leq i \leq n} (x - a_i)} \right),$$

$$(3.36) \quad \text{RAdV}_{(a_1, \dots, a_p)}^0(\lambda_1, \dots, \lambda_p) = \text{R} \circ \text{AdV}_{(a_1, \dots, a_p)}^0(\lambda_1, \dots, \lambda_p).$$

*Remark 3.4.* Let  $g_k(c, x)$  be meromorphic functions of  $x$  with the holomorphic parameter  $c = (c_1, \dots, c_p) \in \mathbb{C}^p$  for  $k = 1, \dots, p$  such that

$$g_k(c, x) \in \sum_{i=1}^p \mathbb{C} \frac{1}{1 - c_i x} \quad \text{if } 0 \neq c_i \neq c_j \neq 0 \quad (1 \leq i < j \leq p, 1 \leq k \leq p).$$

Suppose  $g_1(c, x), \dots, g_p(c, x)$  are linearly independent for any fixed  $c \in \mathbb{C}^p$ . Then there exist entire functions  $a_{i,j}(c)$  of  $c \in \mathbb{C}^p$  such that

$$g_k(x, c) = \sum_{n=1}^p \frac{a_{k,n}(c)x^{n-1}}{\prod_{i=1}^n (1 - c_i x)}$$

and  $(a_{i,j}(c)) \in GL(p, \mathbb{C})$  for any  $c \in \mathbb{C}^p$  (cf. [O3, Lemma 6.3]). Hence the versal addition is essentially unique.

**3.4. Versal operators.** If we apply a middle convolution to a versal addition of the trivial operator  $\partial$ , we have a *versal Jordan-Pochhammer operator*.

$$(3.37) \quad \begin{aligned} P &:= \text{RAd}(\partial^{-\mu}) \circ \text{RAdV}_{(\frac{1}{c_1}, \dots, \frac{1}{c_p})}(\lambda_1, \dots, \lambda_p) \partial \\ &= \text{RAd}(\partial^{-\mu}) \circ \text{R} \left( \partial + \sum_{k=1}^p \frac{\lambda_k x^{k-1}}{\prod_{\nu=1}^k (1 - c_\nu x)} \right) \\ &= \partial^{-\mu+p-1} \left( p_0(x) \partial + q(x) \right) \partial^\mu = \sum_{k=0}^p p_k(x) \partial^{p-k} \end{aligned}$$

with

$$\begin{aligned} p_0(x) &= \prod_{j=1}^p (1 - c_j x), \quad q(x) = \sum_{k=1}^p \lambda_k x^{k-1} \prod_{j=k+1}^p (1 - c_j x), \\ p_k(x) &= \binom{-\mu+p-1}{k} p_0^{(k)}(x) + \binom{-\mu+p-1}{k-1} q^{(k-1)}(x). \end{aligned}$$

We naturally obtain the integral representation of solutions of the versal Jordan-Pochhammer equation  $Pu = 0$ , which we show in the case  $p = 2$  as follows.

**Example 3.5.** We have the *versal Gauss hypergeometric operator*

$$\begin{aligned} P_{c_1, c_2; \lambda_1, \lambda_2, \mu} &:= \text{RAd}(\partial^{-\mu}) \circ \text{RAdV}_{(\frac{1}{c_1}, \frac{1}{c_2})}(\lambda_1, \lambda_2) \partial \\ &= \text{RAd}(\partial^{-\mu}) \circ \text{RAd} \left( (1 - c_1 x)^{\frac{\lambda_1}{c_1} + \frac{\lambda_2}{c_1(c_1 - c_2)}} (1 - c_2 x)^{\frac{\lambda_2}{c_2(c_2 - c_1)}} \right) \\ &= \text{RAd}(\partial^{-\mu}) \circ \text{RAd}_{\text{ei}} \left( -\frac{\lambda_1}{1 - c_1 x} - \frac{\lambda_2 x}{(1 - c_1 x)(1 - c_2 x)} \right) \partial \\ &= \text{RAd}(\partial^{-\mu}) \circ \text{R} \left( \partial + \frac{\lambda_1}{1 - c_1 x} + \frac{\lambda_2 x}{(1 - c_1 x)(1 - c_2 x)} \right) \\ &= \text{Ad}(\partial^{-\mu}) (\partial(1 - c_1 x)(1 - c_2 x) \partial + \partial(\lambda_1(1 - c_2 x) + \lambda_2 x)) \\ &= ((1 - c_1 x) \partial + c_1(\mu - 1)) ((1 - c_2 x) \partial + c_2 \mu) \\ &\quad + \lambda_1 \partial + (\lambda_2 - \lambda_1 c_2)(x \partial + 1 - \mu) \\ &= (1 - c_1 x)(1 - c_2 x) \partial^2 \\ &\quad + ((c_1 + c_2)(\mu - 1) + \lambda_1 + (2c_1 c_2(1 - \mu) + \lambda_2 - \lambda_1 c_2)x) \partial \\ &\quad + (\mu - 1)(c_1 c_2 \mu + \lambda_1 c_2 - \lambda_2), \end{aligned}$$

whose solution is obtained by applying  $I_c^\mu$  to

$$K_{c_1, c_2; \lambda_1, \lambda_2}(x) = (1 - c_1 x)^{\frac{\lambda_1}{c_1} + \frac{\lambda_2}{c_1(c_1 - c_2)}} (1 - c_2 x)^{\frac{\lambda_2}{c_2(c_2 - c_1)}}$$

The equation  $Pu = 0$  has the Riemann scheme

$$(3.38) \quad \left\{ \begin{array}{ccc} x = \frac{1}{c_1} & \frac{1}{c_2} & \infty \\ 0 & 0 & 1 - \mu \\ \frac{\lambda_1}{c_1} + \frac{\lambda_2}{c_1(c_1 - c_2)} + \mu & \frac{\lambda_2}{c_2(c_2 - c_1)} + \mu & -\frac{\lambda_1}{c_1} + \frac{\lambda_2}{c_1 c_2} - \mu. \end{array} ; x \right\}.$$

Thus we have the following well-known confluent equations

$$P_{c_1,0;\lambda_1,\lambda_2,\mu} = (1 - c_1x)\partial^2 + (c_1(\mu - 1) + \lambda_1 + \lambda_2x)\partial - \lambda_2(\mu - 1), \quad (\text{Kummer})$$

$$K_{c_1,0;\lambda_1,\lambda_2} = (1 - c_1x)^{\frac{\lambda_1}{c_1} + \frac{\lambda_2}{c_1^2}} \exp\left(\frac{\lambda_2x}{c_1}\right),$$

$$P_{0,0,0,-1,\mu} = \partial^2 - x\partial + (\mu - 1), \quad (\text{Hermite})$$

$$\begin{aligned} \text{Ad}(e^{\frac{1}{4}x^2})P_{0,0,0,1,\mu} &= (\partial - \frac{1}{2}x)^2 + x(\partial - \frac{1}{2}x) - (\mu - 1) \\ &= \partial^2 + \left(\frac{1}{2} - \mu - \frac{x^2}{4}\right), \end{aligned} \quad (\text{Weber})$$

$$K_{0,0,0,\mp 1} = \exp\left(\int_0^x \pm t dt\right) = \exp\left(\pm \frac{x^2}{2}\right).$$

The solution

$$\begin{aligned} D_{-\mu}(x) &:= (-1)^{-\mu} e^{\frac{x^2}{4}} I_{\infty}^{\mu}(e^{-\frac{x^2}{2}}) = \frac{e^{\frac{x^2}{4}}}{\Gamma(\mu)} \int_x^{\infty} e^{-\frac{t^2}{2}} (t - x)^{\mu-1} dt \\ &= \frac{e^{\frac{x^2}{4}}}{\Gamma(\mu)} \int_0^{\infty} e^{-\frac{(s+x)^2}{2}} s^{\mu-1} ds = \frac{e^{-\frac{x^2}{4}}}{\Gamma(\mu)} \int_0^{\infty} e^{-xs - \frac{t^2}{2}} s^{\mu-1} ds \\ &\sim x^{-\mu} e^{-\frac{x^2}{4}} {}_2F_0\left(\frac{\mu}{2}, \frac{\mu}{2} + \frac{1}{2}; -\frac{2}{x^2}\right) = \sum_{k=0}^{\infty} x^{-\mu} e^{-\frac{x^2}{4}} \frac{\left(\frac{\mu}{2}\right)_k \left(\frac{\mu}{2} + \frac{1}{2}\right)_k}{k!} \left(-\frac{2}{x^2}\right)^k \end{aligned}$$

of Weber's equation  $\frac{d^2u}{dx^2} = \left(\frac{x^2}{4} + \mu - \frac{1}{2}\right)u$  is called a parabolic cylinder function (cf. [WW, §16.5]). Here the above last line is an asymptotic expansion when  $x \rightarrow +\infty$ .

The normal form of Kummer equation is obtained by the coordinate transformation  $y = x - \frac{1}{c_1}$  but we also obtain it as follows:

$$\begin{aligned} P_{c_1;\lambda_1,\lambda_2,\mu} &:= \text{RAd}(\partial^{-\mu}) \circ \text{R} \circ \text{Ad}(x^{\lambda_2}) \circ \text{AdV}_{\frac{1}{c_1}}(\lambda_1)\partial \\ &= \text{RAd}(\partial^{-\mu}) \circ \text{R}\left(\partial - \frac{\lambda_2}{x} + \frac{\lambda_1}{1-c_1x}\right) \\ &= \text{Ad}(\partial^{-\mu})(\partial x(1 - c_1x)\partial - \partial(\lambda_2 - (\lambda_1 + c_1\lambda_2)x)) \\ &= (x\partial + 1 - \mu)((1 - c_1x)\partial + c_1\mu) - \lambda_2\partial + (\lambda_1 + c_1\lambda_2)(x\partial + 1 - \mu) \\ &= x(1 - c_1x)\partial^2 + (1 - \lambda_2 - \mu + (\lambda_1 + c_1(\lambda_2 + 2\mu - 2))x)\partial \\ &\quad + (\mu - 1)(\lambda_1 + c_1(\lambda_2 + \mu)), \end{aligned}$$

$$P_{0;\lambda_1,\lambda_2,\mu} = x\partial^2 + (1 - \lambda_2 - \mu + \lambda_1x)\partial + \lambda_1(\mu - 1),$$

$$P_{0,-1,\lambda_2,\mu} = x\partial^2 + (1 - \lambda_2 - \mu - x)\partial + 1 - \mu \quad (\text{Kummer}),$$

$$K_{c_1;\lambda_1,\lambda_2}(x) := x^{\lambda_2}(1 - c_1x)^{\frac{\lambda_1}{c_1}}, \quad K_{0;\lambda_1,\lambda_2}(x) = x^{\lambda_2} \exp(-\lambda_1x).$$

The Riemann scheme of the equation  $P_{c_1;\lambda_1,\lambda_2,\mu}u = 0$  is

$$(3.39) \quad \left\{ \begin{array}{ccc} x = 0 & \frac{1}{c_1} & \infty \\ 0 & 0 & 1 - \mu \\ \lambda_2 + \mu & \frac{\lambda_1}{c_1} + \mu & -\frac{\lambda_1}{c_1} - \lambda_2 - \mu \end{array} ; x \right\}$$

and the local solution at the origin corresponding to the characteristic exponent  $\lambda_2 + \mu$  is given by

$$I_0^{\mu}(K_{c_1;\lambda_1,\lambda_2})(x) = \frac{1}{\Gamma(\mu)} \int_0^x t^{\lambda_2}(1 - c_1t)^{\frac{\lambda_1}{c_1}} (x - t)^{\mu-1} dt.$$



In particular, we have a solution

$$\begin{aligned}
u(x) &= I_0^\mu(K_{0;-1,\lambda_2})(x) = \frac{1}{\Gamma(\mu)} \int_0^x t^{\lambda_2} e^t (x-t)^{\mu-1} dt \\
&= \frac{x^{\lambda_2+\mu}}{\Gamma(\mu)} \int_0^1 s^{\lambda_2} (1-s)^{\mu-1} e^{xs} ds \quad (t = xs) \\
&= \frac{\Gamma(\lambda_2+1)x^{\lambda_2+\mu}}{\Gamma(\lambda_2+\mu+1)} {}_1F_1(\lambda_2+1, \mu+\lambda_2+1; x)
\end{aligned}$$

of the Kummer equation  $P_{0;-1,\lambda_2,\mu}u = 0$  corresponding to the exponent  $\lambda_2 + \mu$  at the origin. If  $c_1 \notin (-\infty, 0]$  and  $x \notin [0, \infty]$  and  $\lambda_2 \notin \mathbb{Z}_{\geq 0}$ , the local solution at  $-\infty$  corresponding to the exponent  $-\lambda_2 - \frac{\lambda_1}{c_1} - \mu$  is given by

$$\begin{aligned}
&\frac{1}{\Gamma(\mu)} \int_{-\infty}^x (-t)^{\lambda_2} (1-c_1 t)^{\frac{\lambda_1}{c_1}} (x-t)^{\mu-1} dt \\
&= \frac{(-x)^{\lambda_2}}{\Gamma(\mu)} \int_0^\infty \left(1 - \frac{s}{x}\right)^{\lambda_2} (1+c_1(s-x))^{\frac{\lambda_1}{c_1}} s^{\mu-1} ds \quad (s = x-t) \\
&\xrightarrow[c_1 \rightarrow +0]{\lambda_1 = -1} \\
&\frac{(-x)^{\lambda_2}}{\Gamma(\mu)} \int_0^\infty \left(1 - \frac{s}{x}\right)^{\lambda_2} e^{x-s} s^{\mu-1} ds \\
&= \frac{(-x)^{\lambda_2} e^x}{\Gamma(\mu)} \int_0^\infty s^{\mu-1} e^{-s} \left(1 - \frac{s}{x}\right)^{\lambda_2} ds \\
&\sim \sum_{n=0}^\infty \frac{\Gamma(\mu+n)\Gamma(-\lambda_2+n)}{\Gamma(\mu)\Gamma(-\lambda_2)n!x^n} (-x)^{\lambda_2} e^x = (-x)^{\lambda_2} e^x {}_2F_0(-\lambda_2, \mu; \frac{1}{x}).
\end{aligned}$$

Here the above last line is an asymptotic expansion of a rapidly decreasing solution of the Kummer equation when  $\mathbb{R} \ni -x \rightarrow +\infty$ . The Riemann scheme of the equation  $P_{0;-1,\lambda_2,\mu}u = 0$  can be expressed by

$$(3.40) \quad \left\{ \begin{array}{ccc} x = 0 & \infty & (1) \\ 0 & 1 - \mu & 0 \\ \lambda_2 + \mu & -\lambda_2 & 1 \end{array} \right\}.$$

In general, the expression  $\left\{ \begin{array}{ccc} \infty & (r_1) & \cdots & (r_k) \\ \lambda & \alpha_1 & \cdots & \alpha_k \end{array} \right\}$  with  $0 < r_1 < \cdots < r_k$  means the existence of a solution  $u(x)$  satisfying

$$(3.41) \quad u(x) \sim x^{-\lambda} \exp\left(\sum_{\nu=1}^k \alpha_\nu \frac{x^{r_\nu}}{r_\nu}\right) \quad \text{for } |x| \rightarrow \infty$$

under a suitable restriction of  $\text{Arg } x$ . Here  $k \in \mathbb{Z}_{\geq 0}$  and  $\lambda, \alpha_\nu \in \mathbb{C}$ .

#### 4. SERIES EXPANSION

In this section we review the Euler transformation and remark on its relation to middle convolutions.

First we note the following which will be frequently used:

$$(4.1) \quad \int_0^1 t^{\alpha-1} (1-t)^{\beta-1} dt = \frac{\Gamma(\alpha)\Gamma(\beta)}{\Gamma(\alpha+\beta)},$$

$$\begin{aligned}
(1-t)^{-\gamma} &= \sum_{\nu=0}^{\infty} \frac{(-\gamma)(-\gamma-1)\cdots(-\gamma-\nu+1)}{\nu!} (-t)^\nu \\
(4.2) \qquad &= \sum_{\nu=0}^{\infty} \frac{\Gamma(\gamma+\nu)}{\Gamma(\gamma)\nu!} t^\nu = \sum_{\nu=0}^{\infty} \frac{(\gamma)_\nu}{\nu!} t^\nu.
\end{aligned}$$

The integral (4.1) converges if  $\operatorname{Re} \alpha > 0$  and  $\operatorname{Re} \beta > 0$  and the right hand side is meromorphically continued to  $\alpha \in \mathbb{C}$  and  $\beta \in \mathbb{C}$ . If the integral in (4.1) is interpreted in the sense of generalized functions, (4.1) is valid if  $\alpha \notin \{0, -1, -2, \dots\}$  and  $\beta \notin \{0, -1, -2, \dots\}$ .

Euler transformation  $I_c^\mu$  is sometimes expressed by  $\partial^{-\mu}$  and as is shown in ([Kh, §5.1]), we have

$$\begin{aligned}
I_c^\mu u(x) &:= \frac{1}{\Gamma(\mu)} \int_c^x (x-t)^{\mu-1} u(t) dt \\
(4.3) \qquad &= \frac{(x-c)^\mu}{\Gamma(\mu)} \int_0^1 (1-s)^{\mu-1} u((x-c)s+c) ds,
\end{aligned}$$

$$(4.4) \qquad I_c^\mu \circ I_c^{\mu'} = I_c^{\mu+\mu'},$$

$$(4.5) \qquad I_c^{-n} u(x) = \frac{d^n}{dx^n} u(x),$$

$$\begin{aligned}
I_c^\mu \sum_{n=0}^{\infty} c_n (x-c)^{\lambda+n} &= \sum_{n=0}^{\infty} \frac{\Gamma(\lambda+n+1)}{\Gamma(\lambda+\mu+n+1)} c_n (x-c)^{\lambda+\mu+n} \\
(4.6) \qquad &= \frac{\Gamma(\lambda+1)}{\Gamma(\lambda+\mu+1)} \sum_{n=0}^{\infty} \frac{(\lambda+1)_n c_n}{(\lambda+\mu+1)_n} (x-c)^{\lambda+\mu+n},
\end{aligned}$$

$$(4.7) \qquad I_\infty^\mu \sum_{n=0}^{\infty} c_n x^{\lambda-n} = e^{\pi\sqrt{-1}\mu} \sum_{n=0}^{\infty} \frac{\Gamma(-\lambda-\mu+n)}{\Gamma(-\lambda+n)} c_n x^{\lambda+\mu-n}.$$

Moreover the following equalities which follow from (2.47) are also useful.

$$\begin{aligned}
I_0^\mu \sum_{n=0}^{\infty} c_n x^{\lambda+n} (1-x)^\beta & \\
(4.8) \qquad &= \frac{\Gamma(\lambda+1)}{\Gamma(\lambda+\mu+1)} \sum_{m,n=0}^{\infty} \frac{(\lambda+1)_{m+n} (-\beta)_m c_n}{(\lambda+\mu+1)_{m+n} m!} x^{\lambda+\mu+m+n} \\
&= \frac{\Gamma(\lambda+1)}{\Gamma(\lambda+\mu+1)} (1-x)^{-\beta} \sum_{m,n=0}^{\infty} \frac{(\lambda+1)_n (\mu)_m (-\beta)_m c_n}{(\lambda+\mu+1)_{m+n} m!} x^{\lambda+\mu+n} \left(\frac{x}{x-1}\right)^m.
\end{aligned}$$

If  $\lambda \notin \mathbb{Z}_{<0}$  (resp.  $\lambda + \mu \notin \mathbb{Z}_{\geq 0}$ ) and moreover the power series  $\sum_{n=0}^{\infty} c_n t^n$  has a positive radius of convergence, the equalities (4.6) (resp, (4.7)) is valid since  $I_c^\mu$  (resp.  $I_\infty^\mu$ ) can be defined through analytic continuations with respect to the parameters  $\lambda$  and  $\mu$ . Note that  $I_c^\mu$  is an invertible map of  $\mathcal{O}_c(x-c)^\lambda$  onto  $\mathcal{O}_c(x-c)^{\lambda+\mu}$  if  $\lambda \notin \{-1, -2, -3, \dots\}$  and  $\lambda + \mu \notin \{-1, -2, -3, \dots\}$ .

**Proposition 4.1.** *Let  $\lambda$  and  $\mu$  be complex numbers satisfying  $\lambda \notin \mathbb{Z}_{<0}$ . Differentiating the equality (4.6) with respect to  $\lambda$ , we have the linear map*

$$(4.9) \qquad I_c^\mu : \mathcal{O}_c(\lambda, m) \rightarrow \mathcal{O}_c(\lambda + \mu, m)$$

*under the notation (3.5), which is also defined by (4.3) if  $\operatorname{Re} \lambda > -1$  and  $\operatorname{Re} \mu > 0$ . Here  $m$  is a non-negative integer. Then we have*

$$(4.10) \qquad I_c^\mu \left( \sum_{j=0}^m \phi_j \log^j(x-c) \right) - I_c^\mu(\phi_m) \log^m(x-c) \in \mathcal{O}(\lambda + \mu, m-1)$$

for  $\phi_j \in \mathcal{O}_c$  and  $I_c^\mu$  satisfies (2.43). The map (4.9) is bijective if  $\lambda + \mu \notin \mathbb{Z}_{<0}$ . In particular for  $k \in \mathbb{Z}_{\geq 0}$  we have  $I_c^\mu \partial^k = \partial^k I_c^\mu = I_c^{\mu-k}$  on  $\mathcal{O}_c(\lambda, m)$  if  $\lambda - k \notin \{-1, -2, -3, \dots\}$ .

Suppose that  $P \in W[x]$  and  $\phi \in \mathcal{O}_c(\lambda, m)$  satisfy  $P\phi = 0$ ,  $P \neq 0$  and  $\phi \neq 0$ . Let  $k$  and  $N$  be non-negative integers such that

$$(4.11) \quad \partial^k P = \sum_{i=0}^N \sum_{j \geq 0} a_{i,j} \partial^i ((x-c)\partial)^j$$

with suitable  $a_{j,j} \in \mathbb{C}$  and put  $Q = \sum_{i=0}^N \sum_{j \geq 0} c_{i,j} \partial^i ((x-c)\partial - \mu)^j$ . Then if  $\lambda \notin \{N-1, N-2, \dots, 0, -1, \dots\}$ , we have

$$(4.12) \quad I_c^\mu \partial^k P u = Q I_c^\mu(u) \quad \text{for } u \in \mathcal{O}_c(\lambda, m)$$

and in particular  $Q I_c^\mu(\phi) = 0$ .

Fix  $\ell \in \mathbb{Z}$ . For  $u(x) = \sum_{i=\ell}^{\infty} \sum_{j=0}^m c_{i,j} (x-c)^i \log^j(x-c) \in \mathcal{O}_c(\ell, m)$  we put  $(\Gamma_N u)(x) = \sum_{\nu=\max\{\ell, N-1\}}^{\infty} \sum_{j=0}^m c_{i,j} (x-c)^i \log^j(x-c)$ . Then

$$\left( \prod_{\ell-N \leq \nu \leq N-1} ((x-c)\partial - \nu)^{m+1} \right) \partial^k P(u(x) - (\Gamma_N u)(x)) = 0$$

and therefore

$$(4.13) \quad \begin{aligned} & \left( \prod_{\ell-N \leq \nu \leq N-1} ((x-c)\partial - \mu - \nu)^{m+1} \right) Q I_c^\mu(\Gamma_N u) \\ &= I_c^\mu \left( \prod_{\ell-N \leq \nu \leq N-1} ((x-c)\partial - \nu)^{m+1} \right) \partial^k P u. \end{aligned}$$

In particular,  $\prod_{\ell-N \leq \nu \leq N-1} ((x-c)\partial - \mu - \nu)^{m+1} \cdot Q I_c^\mu(\Gamma_N u) = 0$  if  $P u = 0$ .

Suppose moreover  $\lambda \notin \mathbb{Z}$  and  $\lambda + \mu \notin \mathbb{Z}$  and  $Q = ST$  with  $S, T \in W[x]$  such that  $x = c$  is not a singular point of the operator  $S$ . Then  $T I_c^\mu(\phi) = 0$ . In particular,

$$(4.14) \quad (\text{RAd}(\partial^{-\mu})P) I_c^\mu(\phi) = 0.$$

Hence if the differential equation  $(\text{RAd}(\partial^{-\mu})P)v = 0$  is irreducible, we have

$$(4.15) \quad W(x)(\text{RAd}(\partial^{-\mu})P) = \{T \in W(x); T I_c^\mu(\phi) = 0\}.$$

The statements above are also valid even if we replace  $x - c$ ,  $I_c^\mu$  by  $\frac{1}{x}$ ,  $I_\infty^\mu$ , respectively.

*Proof.* It is clear that (4.9) is well-defined and (4.10) is valid. Then (4.9) is bijective because of (4.6) and (4.10). Since (2.43) is valid when  $m = 0$ , it is also valid when  $m = 1, 2, \dots$  by the definition of (4.9).

The equalities (4.6) and (4.7) assure that  $Q I_c^\mu(\phi) = 0$ . Note that  $T I_c^\mu(\phi) \in \mathcal{O}(\lambda + \mu - N, m)$  with a suitable positive integer  $N$ . Since  $\lambda + \mu - N \notin \mathbb{Z}$  and any solution of the equation  $Sv = 0$  is holomorphic at  $x = c$ , the equality  $S(T I_c^\mu(\phi)) = 0$  implies  $T I_c^\mu(\phi) = 0$ .

The remaining claims in the theorem are similarly clear.  $\square$

*Remark 4.2.* i) Let  $\gamma : [0, 1] \rightarrow \mathbb{C}$  be a path such that  $\gamma(0) = c$  and  $\gamma(1) = x$ . Suppose  $u(x)$  is holomorphic along the path  $\gamma(t)$  for  $0 < t \leq 1$  and  $u(\gamma(t)) = \phi(\gamma(t))$  for  $0 < t \ll 1$  with a suitable function  $\phi \in \mathcal{O}_c(\lambda, m)$ . Then  $I_c^\mu(u)$  is defined by the integration along the path  $\gamma$ . In fact, if the path  $\gamma(t)$  with  $t \in [0, 1]$  splits into the three paths corresponding to the decomposition  $[0, 1] = [0, \epsilon] \cup [\epsilon, 1 - \epsilon] \cup [1 - \epsilon, 1]$  with  $0 < \epsilon \ll 1$ . Let  $c_1 = c, \dots, c_p$  be points in  $\mathbb{C}^n$  and suppose moreover  $u(x)$  is extended to a multi-valued holomorphic function on  $\mathbb{C} \setminus \{c_1, \dots, c_p\}$ . Then  $I_c^x(u)$  also defines a multi-valued holomorphic function on  $\mathbb{C} \setminus \{c_1, \dots, c_p\}$ .

ii) Proposition 4.1 is also valid if we replace  $\mathcal{O}_c(\lambda, m)$  by the space of functions given in Remark 2.7 ii). In fact the above proof also works in this case.

## 5. CONTIGUITY RELATION

The following proposition is clear from Proposition 4.1.

**Proposition 5.1.** *Let  $\phi(x)$  be a non-zero solution of an ordinary differential equation  $Pu = 0$  with an operator  $P \in W[x]$ . Let  $P_j$  and  $S_j \in W[x]$  for  $j = 1, \dots, N$  so that  $\sum_{j=1}^N P_j S_j \in W[x]P$ . Then for a suitable  $\ell \in \mathbb{Z}$  we have*

$$(5.1) \quad \sum Q_j(I_c^\mu(\phi_j)) = 0$$

by putting

$$(5.2) \quad \begin{aligned} \phi_j &= S_j \phi, \\ Q_j &= \partial^{\ell-\mu} \circ P_j \circ \partial^\mu \in W[x], \quad (j = 1, \dots, N), \end{aligned}$$

if  $\phi(x) \in \mathcal{O}(\lambda, m)$  with a non-negative integer  $m$  and a complex number  $\lambda$  satisfying  $\lambda \notin \mathbb{Z}$  and  $\lambda + \mu \notin \mathbb{Z}$  or  $\phi(x)$  is a function given in Remark 2.7 ii). If  $P_j = \sum_{k \geq 0, \ell \geq 0} c_{j,k,\ell} \partial^k \vartheta^\ell$  with  $c_{j,k,\ell} \in \mathbb{C}$ , then we can assume  $\ell \leq 0$  in the above. Moreover we have

$$(5.3) \quad \partial(I_c^{\mu+1}(\phi_1)) = I_c^\mu(\phi_1).$$

*Proof.* Fix an integer  $k$  such that  $\partial^k P_j = \tilde{P}_j(\partial, \vartheta) = \sum_{i_1, i_2} c_{i_1, i_2} \partial^{i_1} \vartheta^{i_2}$  with  $c_{i_1, i_2} \in \mathbb{C}$ . Since  $0 = \sum_{j=1}^N \partial^k P_j S_j \phi$ , Proposition 4.1 proves  $0 = \sum_{j=1}^N I_c^\mu(\tilde{P}_j(\partial, \vartheta) S_j \phi) = \sum_{j=1}^N \tilde{P}_j(\partial, \vartheta - \mu) I_c^\mu(S_j \phi)$ , which implies the first claim of the proposition.

The last claim is clear from (4.4) and (4.5).  $\square$

**Corollary 5.2.** *Let  $P(\xi)$  and  $K(\xi)$  be non-zero elements of  $W[x; \xi]$ . If we substitute  $\xi$  and  $\mu$  by generic complex numbers, we assume that there exists a solution  $\phi_\xi(x)$  satisfying the assumption in the preceding proposition and that  $I_c^\mu(\phi_\xi)$  and  $I_c^\mu(K(\xi)\phi_\xi)$  satisfy irreducible differential equations  $T_1(\xi, \mu)v_1 = 0$  and  $T_2(\xi, \mu)v_2 = 0$  with  $T_1(\xi, \mu)$  and  $T_2(\xi, \mu) \in W(x; \xi, \mu)$ , respectively. Then the differential equation  $T_1(\xi, \mu)v_1 = 0$  is isomorphic to  $T_2(\xi, \mu)v_2 = 0$  as  $W(x; \xi, \mu)$ -modules.*

*Proof.* Since  $K(\xi) \cdot 1 - 1 \cdot K(\xi) = 0$ , we have  $Q(\xi, \mu)I_c^\mu(\phi_\xi) = \partial^\ell I_c^\mu(K(\xi)\phi_\xi)$  with  $Q(\xi, \mu) = \partial^{\ell-\mu} \circ K(\xi) \circ \partial^\mu$ . Since  $\partial^\ell I_c^\mu(\phi_\xi) \neq 0$  and the equations  $T_j(\xi, \mu)v_j = 0$  are irreducible for  $j = 1$  and  $2$ , there exist  $R_1(\xi, \mu)$  and  $R_2(\xi, \mu) \in W(x; \xi, \mu)$  such that  $I_c^\mu(\phi_\xi) = R_1(\xi, \mu)Q(\xi, \mu)I_c^\mu(\phi_\xi) = R_1(\xi, \mu)\partial^\ell I_c^\mu(K(\xi)\phi_\xi)$  and  $I_c^\mu(K(\xi)\phi_\xi) = R_2(\xi, \mu)\partial^\ell I_c^\mu(K(\xi)\phi_\xi) = R_2(\xi, \mu)Q(\xi, \mu)I_c^\mu(\phi_\xi)$ . Hence we have the corollary.  $\square$

Using the proposition, we get the contiguity relations with respect to the parameters corresponding to powers of linear functions defining additions and the middle convolutions.

For example, in the case of Gauss hypergeometric functions, we have

$$\begin{aligned} u_{\lambda_1, \lambda_2, \mu}(x) &:= I_0^\mu(x^{\lambda_1}(1-x)^{\lambda_2}), \\ u_{\lambda_1, \lambda_2, \mu-1}(x) &= \partial u_{\lambda_1, \lambda_2, \mu}(x), \\ \partial u_{\lambda_1+1, \lambda_2, \mu}(x) &= (x\partial + 1 - \mu)u_{\lambda_1, \lambda_2, \mu}(x), \\ \partial u_{\lambda_1, \lambda_2+1, \mu}(x) &= ((1-x)\partial + \mu - 1)u_{\lambda_1, \lambda_2, \mu}(x). \end{aligned}$$

Here Proposition 5.1 with  $\phi = x^{\lambda_1}(1-x)^{\lambda_2}$ ,  $(P_1, S_1, P_2, S_2) = (1, x, -x, 1)$  and  $\ell = 1$  gives the above third identity.

Since  $P_{\lambda_1, \lambda_2, \mu} u_{\lambda_1, \lambda_2, \mu}(x) = 0$  with

$$P_{\lambda_1, \lambda_2, \mu} = (x(1-x)\partial + (1-\lambda_1-\mu - (2-\lambda_1-\lambda_2-2\mu)x)\partial - (\mu-1)(\lambda_1+\lambda_2+\mu))$$

as is given in Example 2.8, the inverse of the relation  $u_{\lambda_1, \lambda_2, \mu-1}(x) = \partial u_{\lambda_1, \lambda_2, \mu}(x)$  is

$$u_{\lambda_1, \lambda_2, \mu}(x) = -\frac{x(1-x)\partial + (1-\lambda_1-\mu - (2-\lambda_1-\lambda_2-2\mu)x)}{(\mu-1)(\lambda_1+\lambda_2+\mu)} u_{\lambda_1, \lambda_2, \mu-1}(x).$$

The equalities  $u_{\lambda_1, \lambda_2, \mu-1}(x) = \partial u_{\lambda_1, \lambda_2, \mu}(x)$  and (2.47) mean

$$\begin{aligned} & \frac{\Gamma(\lambda_1+1)x^{\lambda_1+\mu-1}}{\Gamma(\lambda_1+\mu)} F(-\lambda_2, \lambda_1+1, \lambda_1+\mu; x) \\ &= \frac{\Gamma(\lambda_1+1)x^{\lambda_1+\mu-1}}{\Gamma(\lambda_1+\mu)} F(-\lambda_2, \lambda_1+1, \lambda_1+\mu+1; x) \\ &+ \frac{\Gamma(\lambda_1+1)x^{\lambda_1+\mu}}{\Gamma(\lambda_1+\mu+1)} \frac{d}{dx} F(-\lambda_2, \lambda_1+1, \lambda_1+\mu+1; x) \end{aligned}$$

and therefore  $u_{\lambda_1, \lambda_2, \mu-1}(x) = \partial u_{\lambda_1, \lambda_2, \mu}(x)$  is equivalent to

$$(\gamma-1)F(\alpha, \beta, \gamma-1; x) = (\vartheta + \gamma - 1)F(\alpha, \beta, \gamma; x).$$

The contiguity relations are very important for the study of differential equations. For example the author's original proof of the connection formula (1.21) announced in [O6] is based on the relations (cf. §14.3).

Some results related to contiguity relations will be given in §13 but we will not go further in this subject and it will be discussed in another paper.

## 6. FUCHSIAN DIFFERENTIAL EQUATION AND GENERALIZED RIEMANN SCHEME

**6.1. Generalized characteristic exponents.** We examine the Fuchsian differential equations

$$(6.1) \quad P = a_n(x) \frac{d^n}{dx^n} + a_{n-1}(x) \frac{d^{n-1}}{dx^{n-1}} + \cdots + a_0(x)$$

with given local monodromies at regular singular points. For this purpose we first study the condition so that monodromy generators of the solutions of a Fuchsian differential equation is semisimple even when its exponents are not free of multiplicity.

**Lemma 6.1.** *Suppose that the operator (6.1) defined in a neighborhood of the origin has a regular singularity at the origin. We may assume  $a_\nu(x)$  are holomorphic at 0 and  $a_n(0) = a'_n(0) = \cdots = a_n^{(n-1)}(0) = 0$  and  $a_n^{(n)}(0) \neq 0$ . Then the following conditions are equivalent for a positive integer  $k$ .*

$$(6.2) \quad P = x^k R \quad \text{with a suitable holomorphic differential operator } R \text{ at the origin,}$$

$$(6.3) \quad Px^\nu = o(x^{k-1}) \quad \text{for } \nu = 0, \dots, k-1,$$

$$(6.4) \quad Pu = 0 \quad \text{has a solution } x^\nu + o(x^{k-1}) \text{ for } \nu = 0, \dots, k-1,$$

$$(6.5) \quad P = \sum_{j \geq 0} x^j p_j(\vartheta) \quad \text{with polynomials } p_j \text{ satisfying } p_j(\nu) = 0 \text{ for } 0 \leq \nu < k-j \text{ and } j = 0, \dots, k-1.$$

*Proof.* (6.2)  $\Rightarrow$  (6.3)  $\Leftrightarrow$  (6.4) is clear.

Assume (6.3). Then  $Px^\nu = o(x^{k-1})$  for  $\nu = 0, \dots, k-1$  implies  $a_j(x) = x^k b_j(x)$  for  $j = 0, \dots, k-1$ . Since  $P$  has a regular singularity at the origin,  $a_j(x) = x^j c_j(x)$  for  $j = 0, \dots, n$ . Hence we have (6.2).

Since  $Px^\nu = \sum_{j=0}^{\infty} x^{\nu+j} p_j(\nu)$ , the equivalence (6.3)  $\Leftrightarrow$  (6.5) is clear.  $\square$

**Definition 6.2.** Suppose  $P$  in (6.1) has a regular singularity at  $x = 0$ . Under the notation (2.57) we define that  $P$  has a (*generalized*) *characteristic exponent*  $[\lambda]_{(k)}$  at  $x = 0$  if  $x^{n-k} \text{Ad}(x^{-\lambda})(a_n(x)^{-1}P) \in W[x]$ .

Note that Lemma 6.1 shows that  $P$  has a characteristic exponent  $[\lambda]_{(k)}$  at  $x = 0$  if and only if

$$(6.6) \quad x^n a_n(x)^{-1}P = \sum_{j \geq 0} x^j q_j(\vartheta) \prod_{0 \leq i < k-j} (\vartheta - \lambda - i)$$

with polynomials  $q_j(t)$ . By a coordinate transformation we can define generalized characteristic exponents for any regular singular point as follows.

**Definition 6.3** (*generalized characteristic exponents*). Suppose  $P$  in (6.1) has regular singularity at  $x = c$ . Let  $n = m_1 + \dots + m_q$  be a partition of the positive integer  $n$  and let  $\lambda_1, \dots, \lambda_q$  be complex numbers. We define that  $P$  has the (*set of generalized*) *characteristic exponents*  $\{[\lambda_1]_{(m_1)}, \dots, [\lambda_q]_{(m_q)}\}$  and the *spectral type*  $\{m_1, \dots, m_q\}$  at  $x = c \in \mathbb{C} \cup \{\infty\}$  if there exist polynomials  $q_\ell(s)$  such that

$$(6.7) \quad (x-c)^n a_n(x)^{-1}P = \sum_{\ell \geq 0} (x-c)^\ell q_\ell((x-c)\partial) \prod_{\nu=1}^q \prod_{0 \leq i < m_\nu - \ell} ((x-c)\partial - \lambda_\nu - i)$$

in the case when  $c \neq \infty$  and

$$(6.8) \quad x^{-n} a_n(x)^{-1}P = \sum_{\ell \geq 0} x^{-\ell} q_\ell(\vartheta) \prod_{\nu=1}^q \prod_{0 \leq i < m_\nu - \ell} (\vartheta + \lambda_\nu + i)$$

in the case when  $c = \infty$ . Here if  $m_j = 1$ ,  $[\lambda_j]_{(m_j)}$  may be simply written as  $\lambda_j$ .

*Remark 6.4.* i) In Definition 6.3 we may replace the left hand side of (6.7) by  $\phi(x)a_n(x)^{-1}P$  where  $\phi$  is analytic function in a neighborhood of  $x = c$  such that  $\phi(c) = \dots = \phi^{(n-1)}(c) = 0$  and  $\phi^{(n)}(c) \neq 0$ . In particular when  $a_n(c) = \dots = a_n^{(n)}(c) = 0$  and  $a_n(c) \neq 0$ ,  $P$  is said to be *normalized* at the singular point  $x = c$  and the left hand side of (6.7) can be replaced by  $P$ .

In particular when  $c = 0$  and  $P$  is normalized at the regular singular point  $x = 0$ , the condition (6.7) is equivalent to

$$(6.9) \quad \prod_{\nu=1}^k \prod_{0 \leq i < m_\nu - \ell} (s - \lambda_\nu - i) \mid p_j(s) \quad (\forall \ell = 0, 1, \dots, \max\{m_1, \dots, m_k\} - 1)$$

under the expression  $P = \sum_{j=0}^{\infty} x^j p_j(\vartheta)$ .

ii) In Definition 6.3 the condition that the operator  $P$  has a set of generalized characteristic exponents  $\{\lambda_1, \dots, \lambda_n\}$  is equivalent to the condition that it is the set of the usual characteristic exponents.

iii) Any one of  $\{\lambda, \lambda + 1, \lambda + 2\}$ ,  $\{[\lambda]_{(2)}, \lambda + 2\}$  and  $\{\lambda, [\lambda + 1]_{(2)}\}$  is the set of characteristic exponents of

$$P = (\vartheta - \lambda)(\vartheta - \lambda - 1)(\vartheta - \lambda - 2 + x) + x^2(\vartheta - \lambda + 1)$$

at  $x = 0$  but  $\{[\lambda]_{(3)}\}$  is not.

iv) Suppose  $P$  has a holomorphic parameter  $t \in B_1(0)$  (cf. (3.7)) and  $P$  has regular singularity at  $x = c$ . Suppose the set of the corresponding characteristic exponents is  $\{[\lambda_1(t)]_{(m_1)}, \dots, [\lambda_q(t)]_{(m_q)}\}$  for  $t \in B_1(0) \setminus \{0\}$  with  $\lambda_\nu(t) \in \mathcal{O}(B_1(0))$ . Then this is also valid in the case  $t = 0$ , which clearly follows from the definition.

When

$$P = \sum_{\ell \geq 0} x^{-\ell} q_{\ell} ((x-c)\partial) \prod_{\nu=1}^q \prod_{0 \leq i < m_{\nu} - \ell} ((x-c)\partial - \lambda_{\nu} - i),$$

we put

$$P_t = \sum_{\ell \geq 0} x^{-\ell} q_{\ell} ((x-c)\partial) \prod_{\nu=1}^q \prod_{0 \leq i < m_{\nu} - \ell} ((x-c)\partial - \lambda_{\nu} - \nu t - i).$$

Here  $\lambda_{\nu} \in \mathbb{C}$ ,  $q_0 \neq 0$  and  $\text{ord } P = m_1 + \dots + m_q$ . Then the set of the characteristic exponents of  $P_t$  is  $\{[\tilde{\lambda}_1(t)]_{(m_1)}, \dots, [\tilde{\lambda}_q(t)]_{(m_q)}\}$  with  $\tilde{\lambda}_j(t) = \lambda_j + jt$ . Since  $\tilde{\lambda}_i(t) - \tilde{\lambda}_j(t) \notin \mathbb{Z}$  for  $0 < |t| \ll 1$ , we can reduce certain claims to the case when the values of characteristic exponents are generic. Note that we can construct local independent solutions which holomorphically depend on  $t$  (cf. [O4]).

**Lemma 6.5.** i) *Let  $\lambda$  be a complex number and let  $p(t)$  be a polynomial such that  $p(\lambda) \neq 0$ . Then for non-negative integers  $k$  and  $m$  we have the exact sequence*

$$0 \longrightarrow \mathcal{O}_0(\lambda, k-1) \longrightarrow \mathcal{O}_0(\lambda, m+k-1) \xrightarrow{p(\vartheta)(\vartheta-\lambda)^k} \mathcal{O}_0(\lambda, m-1) \longrightarrow 0$$

under the notation (3.5).

ii) *Let  $m_1, \dots, m_q$  be non-negative integers. Let  $P$  be a differential operator of order  $n$  whose coefficients are in  $\mathcal{O}_0$  such that*

$$(6.10) \quad P = \sum_{\ell=0}^{\infty} x^{\ell} r_{\ell}(\vartheta) \prod_{\nu=1}^q \prod_{0 \leq k < m_{\nu} - \ell} (\vartheta - k)$$

with polynomials  $r_{\ell}$ . Put  $m_{\max} = \max\{m_1, \dots, m_q\}$  and suppose  $r_0(\nu) \neq 0$  for  $\nu = 0, \dots, m_{\max} - 1$ .

Let  $\mathbf{m}^{\vee} = (m_1^{\vee}, \dots, m_{m_{\max}}^{\vee})$  be the dual partition of  $\mathbf{m} := (m_1, \dots, m_q)$ , namely,

$$(6.11) \quad m_{\nu}^{\vee} = \#\{j; m_j \geq \nu\}.$$

Then for  $i = 0, \dots, m_{\max} - 1$  and  $j = 0, \dots, m_{i+1}^{\vee} - 1$  we have the functions

$$(6.12) \quad u_{i,j}(x) = x^i \log^j x + \sum_{\mu=i+1}^{m_{\max}-1} \sum_{\nu=0}^j c_{i,j}^{\mu,\nu} x^{\mu} \log^{\nu} x$$

such that  $c_{i,j}^{\mu,\nu} \in \mathbb{C}$  and  $Pu_{i,j} \in \mathcal{O}_0(m_{\max}, j)$ .

iii) *Let  $m'_1, \dots, m'_q$  be non-negative integers and let  $P'$  be a differential operator of order  $n'$  whose coefficients are in  $\mathcal{O}_0$  such that*

$$(6.13) \quad P' = \sum_{\ell=0}^{\infty} x^{\ell} r'_{\ell}(\vartheta) \prod_{\nu=1}^q \prod_{0 \leq k < m'_{\nu} - \ell} (\vartheta - m_{\nu} - k)$$

with polynomials  $q'_{\ell}$ . Then for a differential operator  $P$  of the form (6.10) we have

$$(6.14) \quad P'P = \sum_{\ell=0}^{\infty} x^{\ell} \left( \sum_{\nu=0}^{\ell} r'_{\ell-\nu}(\vartheta + \nu) r_{\nu}(\vartheta) \right) \prod_{\nu=1}^q \prod_{0 \leq k < m_{\nu} + m'_{\nu} - \ell} (\vartheta - k).$$

*Proof.* i) The claim is easy if  $(p, k) = (1, 1)$  or  $(\vartheta - \mu, 0)$  with  $\mu \neq \lambda$ . Then the general case follows from induction on  $\deg p(t) + k$ .

ii) Put  $P = \sum_{\ell \geq 0} x^{\ell} p_{\ell}(\vartheta)$  and  $m_{\nu}^{\vee} = 0$  if  $\nu > m_{\max}$ . Then for a non-negative integer  $\nu$ , the multiplicity of the root  $\nu$  of the equation  $p_{\ell}(t) = 0$  is equal or larger than  $m_{\nu+\ell+1}^{\vee}$  for  $\ell = 1, 2, \dots$ . If  $0 \leq \nu \leq m_{\max} - 1$ , the multiplicity of the root  $\nu$  of the equation  $p_0(t) = 0$  equals  $m_{\nu+1}^{\vee}$ .

For non-negative integers  $i$  and  $j$ , we have

$$x^\ell p_\ell(\vartheta) x^i \log^j x = x^{i+\ell} \sum_{0 \leq \nu \leq j - m_{i+\ell}^\vee} c_{i,j,\ell,\nu} \log^\nu x$$

with suitable  $c_{i,j,\ell,\nu} \in \mathbb{C}$ . In particular,  $p_0(\vartheta) x^i \log^j x = 0$  if  $j < m_i^\vee$ . If  $\ell > 0$  and  $i + \ell < m_{\max}$ , there exist functions

$$v_{i,j,\ell} = x^{i+\ell} \sum_{\nu=0}^j a_{i,j,\ell,\nu} \log^\nu x$$

with suitable  $a_{i,j,\ell,\nu} \in \mathbb{C}$  such that  $p_0(\vartheta) v_{i,j,\ell} = x^\ell p_\ell(\vartheta) x^i \log^j x$  and we define a  $\mathbb{C}$ -linear map  $Q$  by

$$Q x^i \log^j x = - \sum_{\ell=1}^{m_{\max}-i-1} v_{i,j,\ell} = - \sum_{\ell=1}^{m_{\max}-i-1} \sum_{\nu=0}^j a_{i,j,\ell,\nu} x^{i+\ell} \log^\nu x,$$

which implies  $p_0(\vartheta) Q x^i \log^j x = - \sum_{\ell=1}^{m_{\max}-i-1} x^\ell p_\ell(\vartheta) x^i \log^j x$  and  $Q^{m_{\max}} = 0$ . Putting  $Tu := \sum_{\nu=0}^{m_{\max}-1} Q^\nu u$  for  $u \in \sum_{i=0}^{m_{\max}-1} \sum_{j=0}^{q-1} \mathbb{C} x^i \log^j x$ , we have

$$\begin{aligned} PTu &\equiv p_0(\vartheta)Tu + \sum_{\ell=1}^{m_{\max}-1} x^\ell p_\ell(\vartheta)Tu && \text{mod } \mathcal{O}_0(m_{\max}, j) \\ &\equiv p_0(\vartheta)(1-Q)Tu && \text{mod } \mathcal{O}_0(m_{\max}, j) \\ &\equiv p_0(\vartheta)(1-Q)(1+Q+\dots+Q^{m_{\max}-1})u && \text{mod } \mathcal{O}_0(m_{\max}, j) \\ &= p_0(\vartheta)u. \end{aligned}$$

Hence if  $j < m_i^\vee$ ,  $PTx^i \log^j x \equiv 0 \pmod{\mathcal{O}_0(m_{\max}, j)}$  and  $u_{i,j}(x) := Tx^i \log^j x$  are required functions.

iii) Since

$$\begin{aligned} &x^{\ell'} r_{\ell'}'(\vartheta) \prod_{\nu=1}^q \prod_{0 \leq k' < m_\nu' - \ell'} (\vartheta - m_\nu - k') \cdot x^\ell r_\ell(\vartheta) \prod_{\nu=1}^q \prod_{0 \leq k < m_\nu - \ell} (\vartheta - k) \\ &= x^{\ell+\ell'} r_{\ell'}'(\vartheta + \ell) r_\ell(\vartheta) \prod_{\nu=1}^q \prod_{0 \leq k' < m_\nu' - \ell'} (\vartheta - m_\nu - k' + \ell) \prod_{0 \leq k < m_\nu - \ell} (\vartheta - k) \\ &= x^{\ell+\ell'} r_{\ell'}'(\vartheta + \ell) r_\ell(\vartheta) \prod_{\nu=1}^q \prod_{0 \leq k < m_\nu + m_\nu' - \ell - \ell'} (\vartheta - k), \end{aligned}$$

we have the claim.  $\square$

**Definition 6.6** (generalized Riemann scheme). Let  $P \in W[x]$ . Then we call  $P$  is *Fuchsian* in this paper when  $P$  has at most regular singularities in  $\mathbb{C} \cup \{\infty\}$ . Suppose  $P$  is Fuchsian with regular singularities at  $x = c_0 = \infty, c_1, \dots, c_p$  and the functions  $\frac{a_j(x)}{a_n(x)}$  are holomorphic on  $\mathbb{C} \setminus \{c_1, \dots, c_p\}$  for  $j = 0, \dots, n$ . Moreover suppose  $P$  has the set of characteristic exponents  $\{[\lambda_{j,1}]_{(m_{j,1})}, \dots, [\lambda_{j,n_j}]_{(m_{j,n_j})}\}$  at  $x = c_j$ . Then we define the Riemann scheme of  $P$  or the equation  $Pu = 0$  by

$$(6.15) \quad \left\{ \begin{array}{cccc} x = c_0 = \infty & c_1 & \cdots & c_p \\ [\lambda_{0,1}]_{(m_{0,1})} & [\lambda_{1,1}]_{(m_{1,1})} & \cdots & [\lambda_{p,1}]_{(m_{p,1})} \\ \vdots & \vdots & \vdots & \vdots \\ [\lambda_{0,n_0}]_{(m_{0,n_0})} & [\lambda_{1,n_1}]_{(m_{1,n_1})} & \cdots & [\lambda_{p,n_p}]_{(m_{p,n_p})} \end{array} \right\}.$$



*Remark 6.7.* The Riemann scheme (6.15) always satisfies the Fuchs relation (cf. (3.21)):

$$(6.16) \quad \sum_{j=0}^p \sum_{\nu=1}^{n_j} \sum_{i=0}^{m_{j,\nu}-1} (\lambda_{j,\nu} + i) = \frac{(p-1)n(n-1)}{2}.$$

**Definition 6.8** (spectral type). In Definition 6.6 we put

$$\mathbf{m} = (m_{0,1}, \dots, m_{0,n_0}; m_{1,1}, \dots; m_{p,1}, \dots, m_{p,n_p}),$$

which will be also written as  $m_{0,1}m_{0,2} \cdots m_{0,n_0}, m_{1,1} \cdots, m_{p,1} \cdots m_{p,n_p}$  for simplicity. Then  $\mathbf{m}$  is a  $(p+1)$ -tuple of partitions of  $n$  and we define that  $\mathbf{m}$  is the *spectral type* of  $P$ .

If the set of (usual) characteristic exponents

$$(6.17) \quad \Lambda_j := \{\lambda_{j,\nu} + i; 0 \leq i \leq m_{j,\nu} - 1 \text{ and } \nu = 1, \dots, n_\nu\}$$

of the Fuchsian differential operator  $P$  at every regular singular point  $x = c_j$  are  $n$  different complex numbers,  $P$  is said to have *distinct exponents*.

*Remark 6.9.* We remark that the Fuchsian differential equation  $\mathcal{M} : Pu = 0$  is irreducible (cf. Definition 2.10) if and only if the monodromy of the equation is irreducible.

If  $P = QR$  with  $Q$  and  $R \in W(x; \xi)$ , the solution space of the equation  $Qv = 0$  is a subspace of that of  $\mathcal{M}$  and closed under the monodromy and therefore the monodromy is reducible. Suppose the space spanned by certain linearly independent solutions  $u_1, \dots, u_m$  is invariant under the monodromy. We have a non-trivial simultaneous solution of the linear relations  $b_m u_j^{(m)} + \cdots + b_1 u_j^{(1)} + b_0 u_j = 0$  for  $j = 1, \dots, m$ . Then  $\frac{b_j}{b_m}$  are single-valued holomorphic functions on  $\mathbb{C} \cup \{\infty\}$  excluding finite number of singular points. In view of the local behavior of solutions, the singularities of  $\frac{b_j}{b_m}$  are at most poles and hence they are rational functions. Then we may assume  $R = b_m \partial^m + \cdots + b_0 \in W(x; \xi)$  and  $P \in W(x; \xi)R$ .

Here we note that  $R$  is Fuchsian but  $R$  may have a singularity which is not a singularity of  $P$  and is an *apparent singularity*. For example, we have

$$(6.18) \quad x(1-x)\partial^2 + (\gamma - \alpha x)\partial + \alpha = \left(\frac{\gamma}{\alpha} - x\right)^{-1} \left(x(1-x)\partial + (\gamma - \alpha x)\right) \left(\left(\frac{\gamma}{\alpha} - x\right)\partial + 1\right).$$

We also note that the equation  $\partial^2 u = xu$  is irreducible and the monodromy of its solutions is reducible.

**6.2. Tuples of partitions.** For our purpose it will be better to allow some  $m_{j,\nu}$  equal 0 and we generalize the notation of tuples of partitions as in [O6].

**Definition 6.10.** Let  $\mathbf{m} = (m_{j,\nu})_{\substack{j=0,1,\dots \\ \nu=1,2,\dots}}$  be an ordered set of infinite number of non-negative integers indexed by non-negative integers  $j$  and positive integers  $\nu$ . Then  $\mathbf{m}$  is called a  $(p+1)$ -tuple of partitions of  $n$  if the following two conditions are satisfied.

$$(6.19) \quad \sum_{\nu=1}^{\infty} m_{j,\nu} = n \quad (j = 0, 1, \dots),$$

$$(6.20) \quad m_{j,1} = n \quad (\forall j > p).$$

A  $(p+1)$ -tuple of partition  $\mathbf{m}$  is called *monotone* if

$$(6.21) \quad m_{j,\nu} \geq m_{j,\nu+1} \quad (j = 0, 1, \dots, \nu = 1, 2, \dots)$$

and called *trivial* if  $m_{j,\nu} = 0$  for  $j = 0, 1, \dots$  and  $\nu = 2, 3, \dots$ . Moreover  $\mathbf{m}$  is called *standard* if  $\mathbf{m}$  is monotone and  $m_{j,2} > 0$  for  $j = 0, \dots, p$ . The greatest common divisor of  $\{m_{j,\nu}; j = 0, 1, \dots, \nu = 1, 2, \dots\}$  is denoted by  $\text{gcd } \mathbf{m}$  and  $\mathbf{m}$  is

called *divisible* (resp. *indivisible*) if  $\gcd \mathbf{m} \geq 2$  (resp.  $\gcd \mathbf{m} = 1$ ). The totality of  $(p+1)$ -tuples of partitions of  $n$  are denoted by  $\mathcal{P}_{p+1}^{(n)}$  and we put

$$(6.22) \quad \mathcal{P}_{p+1} := \bigcup_{n=0}^{\infty} \mathcal{P}_{p+1}^{(n)}, \quad \mathcal{P}^{(n)} := \bigcup_{p=0}^{\infty} \mathcal{P}_{p+1}^{(n)}, \quad \mathcal{P} := \bigcup_{p=0}^{\infty} \mathcal{P}_{p+1},$$

$$(6.23) \quad \text{ord } \mathbf{m} := n \quad \text{if } \mathbf{m} \in \mathcal{P}^{(n)},$$

$$(6.24) \quad \mathbf{1} := (1, 1, \dots) = (m_{j,\nu} = \delta_{\nu,1})_{\substack{j=0,1,\dots \\ \nu=1,2,\dots}} \in \mathcal{P}^{(1)},$$

$$(6.25) \quad \text{idx}(\mathbf{m}, \mathbf{m}') := \sum_{j=0}^p \sum_{\nu=1}^{\infty} m_{j,\nu} m'_{j,\nu} - (p-1) \text{ord } \mathbf{m} \cdot \text{ord } \mathbf{m}',$$

$$(6.26) \quad \text{idx } \mathbf{m} := \text{idx}(\mathbf{m}, \mathbf{m}) = \sum_{j=0}^p \sum_{\nu=1}^{\infty} m_{j,\nu}^2 - (p-1) \text{ord } \mathbf{m}^2,$$

$$(6.27) \quad \text{Pidx } \mathbf{m} := 1 - \frac{\text{idx } \mathbf{m}}{2}.$$

Here  $\text{ord } \mathbf{m}$  is called the *order* of  $\mathbf{m}$ . For  $\mathbf{m}, \mathbf{m}' \in \mathcal{P}$  and a non-negative integer  $k$ ,  $\mathbf{m} + k\mathbf{m}' \in \mathcal{P}$  is naturally defined. Note that

$$(6.28) \quad \text{idx}(\mathbf{m} + \mathbf{m}') = \text{idx } \mathbf{m} + \text{idx } \mathbf{m}' + 2 \text{idx}(\mathbf{m}, \mathbf{m}'),$$

$$(6.29) \quad \text{Pidx}(\mathbf{m} + \mathbf{m}') = \text{Pidx } \mathbf{m} + \text{Pidx } \mathbf{m}' - \text{idx}(\mathbf{m}, \mathbf{m}') - 1.$$

For  $\mathbf{m} \in \mathcal{P}_{p+1}^{(n)}$  we choose integers  $n_0, \dots, n_k$  so that  $m_{j,\nu} = 0$  for  $\nu > n_j$  and  $j = 0, \dots, p$  and we will sometimes express  $\mathbf{m}$  as

$$\begin{aligned} \mathbf{m} &= (\mathbf{m}_0, \mathbf{m}_1, \dots, \mathbf{m}_p) \\ &= m_{0,1}, \dots, m_{0,n_0}; \dots; m_{k,1}, \dots, m_{p,n_p} \\ &= m_{0,1} \cdots m_{0,n_0}, m_{1,1} \cdots m_{1,n_1}, \dots, m_{k,1} \cdots m_{p,n_p} \end{aligned}$$

if there is no confusion. Similarly  $\mathbf{m} = (m_{0,1}, \dots, m_{0,n_0})$  if  $\mathbf{m} \in \mathcal{P}_1$ . Here

$$\mathbf{m}_j = (m_{j,1}, \dots, m_{j,n_j}) \quad \text{and} \quad \text{ord } \mathbf{m} = m_{j,1} + \dots + m_{j,n_j} \quad (0 \leq j \leq p).$$

For example  $\mathbf{m} = (m_{j,\nu}) \in \mathcal{P}_3^{(4)}$  with  $m_{1,1} = 3$  and  $m_{0,\nu} = m_{2,\nu} = m_{1,2} = 1$  for  $\nu = 1, \dots, 4$  will be expressed by

$$\mathbf{m} = 1, 1, 1, 1; 3, 1; 1, 1, 1, 1 = 1111, 31, 1111 = 1^4, 31, 1^4.$$

Let  $\mathfrak{S}_{\infty}$  be the restricted permutation group of the set of indices  $\{0, 1, 2, 3, \dots\} = \mathbb{Z}_{\geq 0}$ , which is generated by the transpositions  $(j, j+1)$  with  $j \in \mathbb{Z}_{\geq 0}$ . Put  $\mathfrak{S}'_{\infty} = \{\sigma \in \mathfrak{S}_{\infty}; \sigma(0) = 0\}$ , which is isomorphic to  $\mathfrak{S}_{\infty}$ .

**Definition 6.11.** The transformation groups  $S_{\infty}$  and  $S'_{\infty}$  of  $\mathcal{P}$  are defined by

$$(6.30) \quad \begin{aligned} S_{\infty} &:= H \ltimes S'_{\infty}, \\ S'_{\infty} &:= \{(\sigma_i)_{i=0,1,\dots}; \sigma_i \in \mathfrak{S}'_{\infty}, \sigma_i = 1 \ (i \gg 1)\}, \quad H \simeq \mathfrak{S}_{\infty}, \\ m'_{j,\nu} &= m_{\sigma(j), \sigma_j(\nu)} \quad (j = 0, 1, \dots, \nu = 1, 2, \dots) \end{aligned}$$

for  $g = (\sigma, \sigma_1, \dots) \in S_{\infty}$ ,  $\mathbf{m} = (m_{j,\nu}) \in \mathcal{P}$  and  $\mathbf{m}' = g\mathbf{m}$ . A tuple  $\mathbf{m} \in \mathcal{P}$  is *isomorphic* to a tuple  $\mathbf{m}' \in \mathcal{P}$  if there exists  $g \in S_{\infty}$  such that  $\mathbf{m}' = g\mathbf{m}$ . We denote by  $s\mathbf{m}$  the unique monotone element in  $S'_{\infty} \mathbf{m}$ .

**Definition 6.12.** For a tuple of partitions  $\mathbf{m} = (m_{j,\nu})_{\substack{1 \leq \nu \leq n_j \\ 0 \leq j \leq p}} \in \mathcal{P}_{p+1}$  and  $\lambda = (\lambda_{j,\nu})_{\substack{1 \leq \nu \leq n_j \\ 0 \leq j \leq p}}$  with  $\lambda_{j,\nu} \in \mathbb{C}$ , we define

$$(6.31) \quad |\{\lambda_{\mathbf{m}}\}| := \sum_{j=0}^p \sum_{\nu=1}^{n_j} m_{j,\nu} \lambda_{j,\nu} - \text{ord } \mathbf{m} + \frac{\text{idx } \mathbf{m}}{2}.$$

We note that the Fuchs relation (6.16) is equivalent to

$$(6.32) \quad |\{\lambda_{\mathbf{m}}\}| = 0$$

because

$$\begin{aligned} \sum_{j=0}^p \sum_{\nu=1}^{n_j} \sum_{i=0}^{m_{j,\nu}-1} i &= \frac{1}{2} \sum_{j=0}^p \sum_{\nu=1}^{n_j} m_{j,\nu} (m_{j,\nu} - 1) = \frac{1}{2} \sum_{j=0}^p \sum_{\nu=1}^{n_j} m_{j,\nu}^2 - \frac{1}{2} (p+1)n \\ &= \frac{1}{2} (\text{idx } \mathbf{m} + (p-1)n^2) - \frac{1}{2} (p+1)n \\ &= \frac{1}{2} \text{idx } \mathbf{m} - n + \frac{(p-1)n(n-1)}{2}. \end{aligned}$$

**6.3. Conjugacy classes of matrices.** Now we review on the conjugacy classes of matrices. For  $\mathbf{m} = (m_1, \dots, m_N) \in \mathcal{P}_1^{(n)}$  and  $\lambda = (\lambda_1, \dots, \lambda_N) \in \mathbb{C}^N$  we define a matrix  $L(\mathbf{m}; \lambda) \in M(n, \mathbb{C})$  as follows, which is introduced and effectively used by [O2] and [O6]:

If  $\mathbf{m}$  is monotone, then

$$(6.33) \quad L(\mathbf{m}; \lambda) := \left( A_{ij} \right)_{\substack{1 \leq i \leq N \\ 1 \leq j \leq N}}, \quad A_{i,j} \in M(m_i, m_j, \mathbb{C}),$$

$$A_{ij} = \begin{cases} \lambda_i I_{m_i} & (i = j), \\ I_{m_i, m_j} := (\delta_{\mu\nu})_{\substack{1 \leq \mu \leq m_i \\ 1 \leq \nu \leq m_j}} = \begin{pmatrix} I_{m_j} \\ 0 \end{pmatrix} & (i = j-1), \\ 0 & (i \neq j, j-1). \end{cases}$$

Here  $I_{m_i}$  denote the identity matrix of size  $m_i$  and  $M(m_i, m_j, \mathbb{C})$  means the set of matrices of size  $m_i \times m_j$  with components in  $\mathbb{C}$  and  $M(m, \mathbb{C}) := M(m, m, \mathbb{C})$ .

For example

$$L(2, 1, 1; \lambda_1, \lambda_2, \lambda_3) := \begin{pmatrix} \lambda_1 & 0 & 1 \\ 0 & \lambda_1 & 0 \\ & \lambda_2 & 1 \\ & & & \lambda_3 \end{pmatrix}.$$

If  $\mathbf{m}$  is not monotone, we fix a permutation  $\sigma$  of  $\{1, \dots, N\}$  so that  $(m_{\sigma(1)}, \dots, m_{\sigma(N)})$  is monotone and put  $L(\mathbf{m}; \lambda) = L(m_{\sigma(1)}, \dots, m_{\sigma(N)}; \lambda_{\sigma(1)}, \dots, \lambda_{\sigma(N)})$ .

When  $\lambda_1 = \dots = \lambda_N = \mu$ ,  $L(\mathbf{m}; \lambda)$  may be simply denoted by  $L(\mathbf{m}, \mu)$ .

We denote  $A \sim B$  for  $A, B \in M(n, \mathbb{C})$  if and only if there exists  $g \in GL(n, \mathbb{C})$  with  $B = gAg^{-1}$ .

When  $A \sim L(\mathbf{m}; \lambda)$ ,  $\mathbf{m}$  is called the *spectral type* of  $A$  and denoted by  $\text{spc } A$  with a monotone  $\mathbf{m}$ .

*Remark 6.13.* i) If  $\mathbf{m} = (m_1, \dots, m_K) \in \mathcal{P}_1^{(n)}$  is monotone, we have

$$A \sim L(\mathbf{m}; \lambda) \Leftrightarrow \text{rank} \prod_{\nu=1}^j (A - \lambda_{\nu}) = n - (m_1 + \dots + m_j) \quad (j = 0, 1, \dots, K).$$

ii) For  $\mu \in \mathbb{C}$ , put

$$(6.34) \quad (\mathbf{m}; \lambda)_\mu = (m_{i_1}, \dots, m_{i_K}; \mu) \quad \text{with} \quad \{i_1, \dots, i_K\} = \{i; \lambda_i = \mu\}.$$

Then we have

$$(6.35) \quad L(\mathbf{m}; \lambda) \sim \bigoplus_{\mu \in \mathbb{C}} L((\mathbf{m}; \lambda)_\mu).$$

iii) Suppose  $\mathbf{m}$  is monotone. Then for  $\mu \in \mathbb{C}$

$$(6.36) \quad L(\mathbf{m}, \mu) \sim \bigoplus_{j=1}^{m_1} J(\max\{\nu; m_\nu \geq j\}, \mu),$$

$$J(k, \mu) := L(1^k, \mu) \in M(k, \mathbb{C}).$$

iv) For  $A \in M(n, \mathbb{C})$ , we put  $Z(A) = Z_{M(n, \mathbb{C})}(A) := \{X \in M(n, \mathbb{C}); AX = XA\}$ . Then

$$\dim Z_{M(n, \mathbb{C})}(L(\mathbf{m}, \lambda)) = m_1^2 + m_2^2 + \dots$$

v) (cf. [O8, Lemma 3.1]). Let  $\mathbf{A}(t) : [0, 1) \rightarrow M(n, \mathbb{C})$  be a continuous function. Suppose there exist a continuous function  $\lambda = (\lambda_1, \dots, \lambda_K) : [0, 1) \rightarrow \mathbb{C}^K$  such that  $A(t) \sim L(\mathbf{m}; \lambda(t))$  for  $t \in (0, 1)$ . Then

$$(6.37) \quad A(0) \sim L(\mathbf{m}; \lambda(0)) \quad \text{if and only if} \quad \dim Z(A(0)) = m_1^2 + \dots + m_K^2.$$

Note that the Jordan canonical form of  $L(\mathbf{m}; \lambda)$  is easily obtained by (6.35) and (6.36). For example,  $L(2, 1, 1; \mu) \simeq J(3, \mu) \oplus J(1, \mu)$ .

#### 6.4. Realizable tuples of partitions.

**Proposition 6.14.** *Let  $Pu = 0$  be a differential equation of order  $n$  which has a regular singularity at 0. Let  $\{[\lambda_1]_{(m_1)}, \dots, [\lambda_q]_{(m_q)}\}$  be the corresponding set of the characteristic exponents. Here  $\mathbf{m} = (m_1, \dots, m_q)$  a partition of  $n$ .*

i) *Suppose there exists  $k$  such that*

$$\begin{aligned} \lambda_1 &= \lambda_2 = \dots = \lambda_k, \\ m_1 &\geq m_2 \geq \dots \geq m_k, \\ \lambda_j - \lambda_1 &\notin \mathbb{Z} \quad (j = k+1, \dots, q). \end{aligned}$$

*Let  $\mathbf{m}^\vee = (m_1^\vee, \dots, m_r^\vee)$  be the dual partition of  $(m_1, \dots, m_k)$  (cf. (6.11)). Then for  $i = 0, \dots, m_1 - 1$  and  $j = 0, \dots, m_{i+1}^\vee - 1$  the equation has the solutions*

$$(6.38) \quad u_{i,j}(x) = \sum_{\nu=0}^j x^{\lambda_1+i} \log^\nu x \cdot \phi_{i,j,\nu}(x).$$

*Here  $\phi_{i,j,\nu}(x) \in \mathcal{O}_0$  and  $\phi_{i,j,\nu}(0) = \delta_{\nu,j}$  for  $\nu = 0, \dots, j-1$ .*

ii) *Suppose*

$$(6.39) \quad \lambda_i - \lambda_j \notin \mathbb{Z} \setminus \{0\} \quad (0 \leq i < j \leq q).$$

*In this case we say that the set of characteristic exponents  $\{[\lambda_1]_{(m_1)}, \dots, [\lambda_q]_{(m_q)}\}$  is distinguished. Then the monodromy generator of the solutions of the equation at 0 is conjugate to*

$$L(\mathbf{m}; (e^{2\pi\sqrt{-1}\lambda_1}, \dots, e^{2\pi\sqrt{-1}\lambda_q})).$$

*Proof.* Lemma 6.5 ii) shows that there exist  $u_{i,j}(x)$  of the form stated in i) which satisfy  $Pu_{i,j}(x) \in \mathcal{O}_0(\lambda_1 + m_1, j)$  and then we have  $v_{i,j}(x) \in \mathcal{O}_0(\lambda_1 + m_1, j)$  such that  $Pu_{i,j}(x) = Pv_{i,j}(x)$  because of (3.6). Thus we have only to replace  $u_{i,j}(x)$  by  $u_{i,j}(x) - v_{i,j}(x)$  to get the claim in i). The claim in ii) follows from that of i).  $\square$

*Remark 6.15.* i) Suppose  $P$  is a Fuchsian differential operator with regular singularities at  $x = c_0 = \infty, c_1, \dots, c_p$  and moreover suppose  $P$  has distinct exponents. Then the Riemann scheme of  $P$  is (6.15) if and only if  $Pu = 0$  has local solutions  $u_{j,\nu,i}(x)$  of the form

$$(6.40) \quad u_{j,\nu,i}(x) = \begin{cases} (x - c_j)^{\lambda_{j,\nu}+i} (1 + o(|x - c_j|^{m_{j,\nu}-i-1})) \\ \quad (x \rightarrow c_j, i = 0, \dots, m_{j,\nu} - 1, j = 1, \dots, p), \\ x^{-\lambda_{0,\nu}-i} (1 + o(x^{-m_{0,\nu}+i+1})) \\ \quad (x \rightarrow \infty, i = 0, \dots, m_{0,\nu}). \end{cases}$$

Moreover suppose  $\lambda_{j,\nu} - \lambda_{j,\nu'} \notin \mathbb{Z}$  for  $1 \leq \nu < \nu' \leq n_j$  and  $j = 0, \dots, p$ . Then

$$(6.41) \quad u_{j,\nu,i}(x) = \begin{cases} (x - c_j)^{\lambda_{j,\nu}+i} \phi_{j,\nu,i}(x) & (1 \leq j \leq p) \\ x^{-\lambda_{0,\nu}-i} \phi_{0,\nu,i}(x) & (j = 0) \end{cases}$$

with  $\phi_{j,\nu,i}(x) \in \mathcal{O}_{c_j}$  satisfying  $\phi_{j,\nu,i}(c_j) = 1$ . In this case  $P$  has the Riemann scheme (6.15) if and only if at the each singular point  $x = c_j$ , the set of characteristic exponents of the equation  $Pu = 0$  equals  $\Lambda_j$  in (6.17) and the monodromy generator of its solutions is semisimple.

ii) Suppose  $P$  has the Riemann scheme (6.15) and  $\lambda_{1,1} = \dots = \lambda_{1,n_1}$ . Then the monodromy generator of the solutions of  $Pu = 0$  at  $x = c_1$  has the eigenvalue  $e^{2\pi\sqrt{-1}\lambda_{1,1}}$  with multiplicity  $n$ . Moreover the monodromy generator is conjugate to the matrix  $L((m_{1,1}, \dots, m_{1,n_1}), e^{2\pi\sqrt{-1}\lambda_{1,1}})$ , which is also conjugate to

$$J(m_{1,1}^\vee, e^{2\pi\sqrt{-1}\lambda_{1,1}}) \oplus \dots \oplus J(m_{1,n_1}^\vee, e^{2\pi\sqrt{-1}\lambda_{1,1}}).$$

Here  $(m_{1,1}^\vee, \dots, m_{1,n_1}^\vee)$  is the dual partition of  $(m_{1,1}, \dots, m_{1,n_1})$ . A little weaker condition for  $\lambda_{j,\nu}$  assuring the same conclusion is given in Proposition 11.9.

**Definition 6.16** (realizable spectral type). Let  $\mathbf{m} = (\mathbf{m}_0, \dots, \mathbf{m}_p)$  be a  $(p+1)$ -tuple of partitions of a positive integer  $n$ . Here  $\mathbf{m}_j = (m_{j,1}, \dots, m_{j,n_j})$  and  $n = m_{j,1} + \dots + m_{j,n_j}$  for  $j = 0, \dots, p$  and  $m_{j,\nu}$  are non-negative numbers. Fix  $p$  different points  $c_j$  ( $j = 1, \dots, p$ ) in  $\mathbb{C}$  and put  $c_0 = \infty$ .

Then  $\mathbf{m}$  is a *realizable spectral type* if there exists a Fuchsian operator  $P$  with the Riemann scheme (6.15) for generic  $\lambda_{j,\nu}$  satisfying the Fuchs relation (6.16). Moreover in this case if there exists such  $P$  so that the equation  $Pu = 0$  is irreducible, which is equivalent to say that the monodromy of the equation is irreducible, then  $\mathbf{m}$  is *irreducibly realizable*.

*Remark 6.17.* i) In the above definition  $\{\lambda_{j,\nu}\}$  are generic if, for example,  $0 < m_{0,1} < \text{ord } \mathbf{m}$  and  $\{\lambda_{j,\nu}; (j,\nu) \neq (0,1), j = 0, \dots, p, 1 \leq \nu \leq n_j\} \cup \{1\}$  are linearly independent over  $\mathbb{Q}$ .

ii) It follows from the facts (cf. (3.22)) in §3.1 that if  $\mathbf{m} \in \mathcal{P}$  satisfies

$$(6.42) \quad |\{\lambda_{\mathbf{m}'}\}| \notin \mathbb{Z}_{\leq 0} = \{0, -1, -2, \dots\} \text{ for any } \mathbf{m}', \mathbf{m}'' \in \mathcal{P} \\ \text{satisfying } \mathbf{m} = \mathbf{m}' + \mathbf{m}'' \text{ and } 0 < \text{ord } \mathbf{m}' < \text{ord } \mathbf{m},$$

the Fuchsian differential equation with the Riemann scheme (6.15) is irreducible. Hence if  $\mathbf{m}$  is indivisible and realizable,  $\mathbf{m}$  is irreducibly realizable.

Fix distinct  $p$  points  $c_1, \dots, c_p$  in  $\mathbb{C}$  and put  $c_0 = \infty$ . The Fuchsian differential operator  $P$  with regular singularities at  $x = c_j$  for  $j = 1, \dots, p$  has the *normal form*

$$(6.43) \quad P = \left( \prod_{j=1}^p (x - c_j)^n \right) \partial^n + a_{n-1}(x) \partial^{n-1} + \dots + a_1(x) \partial + a_0(x),$$

where  $a_i(x) \in \mathbb{C}[x]$  satisfy

$$(6.44) \quad \deg a_i(x) \leq (p-1)n + i,$$

$$(6.45) \quad (\partial^\nu a_i)(c_j) = 0 \quad (0 \leq \nu \leq i-1)$$

for  $i = 0, \dots, n-1$ .

Note that the condition (6.44) (resp. (6.45)) corresponds to the fact that  $P$  has regular singularities at  $x = c_j$  for  $j = 1, \dots, p$  (resp. at  $x = \infty$ ).

Since  $a_i(x) = b_i(x) \prod_{j=1}^p (x - c_j)^i$  with  $b_i(x) = \sum_{r=0}^{(p-1)(n-i)} b_{i,r} x^r \in W[x]$  satisfying  $\deg b_i(x) \leq (p-1)n + i - pi = (p-1)(n-i)$ , the operator  $P$  has the parameters  $\{b_{i,r}\}$ . The numbers of the parameters equals

$$\sum_{i=0}^{n-1} ((p-1)(n-i) + 1) = \frac{(pn + p - n + 1)n}{2},$$

The condition  $(x - c_j)^{-k} P \in W[x]$  implies  $(\partial^\ell a_i)(c_j) = 0$  for  $0 \leq \ell \leq k-1$  and  $0 \leq i \leq n$ , which equals  $(\partial^\ell b_i)(c_j) = 0$  for  $0 \leq \ell \leq k-1-i$  and  $0 \leq i \leq k-1$ . Therefore the condition

$$(6.46) \quad (x - c_j)^{-m_{j,\nu}} \text{Ad}((x - c_j)^{-\lambda_{j,\nu}}) P \in W[x]$$

gives  $\frac{(m_{j,\nu}+1)m_{j,\nu}}{2}$  independent linear equations for  $\{b_{\nu,r}\}$  since  $\sum_{i=0}^{m_{j,\nu}-1} (m_{j,\nu} - i) = \frac{(m_{j,\nu}+1)m_{j,\nu}}{2}$ . If all these equations have a simultaneous solution and they are independent except for the relation caused by the Fuchs relation, the number of the parameters of the solution equals

$$(6.47) \quad \begin{aligned} & \frac{(pn + p - n + 1)n}{2} - \sum_{j=0}^p \sum_{\nu=1}^{n_j} \frac{m_{j,\nu}(m_{j,\nu} + 1)}{2} + 1 \\ &= \frac{(pn + p - n + 1)n}{2} - \sum_{j=0}^p \sum_{\nu=1}^{n_j} \frac{m_{j,\nu}^2}{2} - (p+1) \frac{n}{2} + 1 \\ &= \frac{1}{2} \left( (p-1)n^2 - \sum_{j=0}^p \sum_{\nu=1}^{n_j} m_{j,\nu}^2 + 1 \right) = \text{Pidx } \mathbf{m}. \end{aligned}$$

*Remark 6.18* (cf. [O6, §5]). Katz [Kz] introduced the *index of rigidity* of an irreducible local system by the number  $\text{idx } \mathbf{m}$  whose spectral type equals  $\mathbf{m} = (m_{j,\nu})_{\substack{j=0,\dots,p \\ \nu=1,\dots,n_j}}$  and proves  $\text{idx } \mathbf{m} \leq 2$ , if the local system is irreducible.

Assume the local system is irreducible. Then Katz [Kz] shows that the local system is uniquely determined by the local monodromies if and only if  $\text{idx } \mathbf{m} = 2$  and in this case the local system and the tuple of partition  $\mathbf{m}$  are called *rigid*. If  $\text{idx } \mathbf{m} > 2$ , the corresponding system of differential equations of *Schleginger normal form*

$$(6.48) \quad \frac{du}{dx} = \sum_{j=1}^p \frac{A_j}{x - a_j} u$$

has  $2\text{Pidx } \mathbf{m}$  parameters which are independent from the characteristic exponents and local monodromies. They are called *accessory parameters*. Here  $A_j$  are constant square matrices of size  $n$ . The number of accessory parameters of the single Fuchsian differential operator without apparent singularities will be the half of this number  $2\text{Pidx } \mathbf{m}$  (cf. Theorem 8.13 and [Sz]).

Lastly in this subsection we calculate the Riemann scheme of the products and the dual of Fuchsian differential operators.

**Theorem 6.19.** *Let  $P$  be a Fuchsian differential operator with the Riemann scheme (6.15). Suppose  $P$  has the normal form (6.43).*

i) *Let  $P'$  be a Fuchsian differential operator with regular singularities also at  $x = c_0 = \infty, c_1, \dots, c_p$ . Then if  $P'$  has the Riemann scheme*

$$(6.49) \quad \left\{ \begin{array}{cc} x = c_0 = \infty & c_j \quad (j = 1, \dots, p) \\ [\lambda_{0,1} + m_{0,1} - (p-1) \text{ord } \mathbf{m}]_{(m'_{0,1})} & [\lambda_{j,1} + m_{j,1}]_{(m'_{j,1})} \\ \vdots & \vdots \\ [\lambda_{0,n_0} + m_{0,n_0} - (p-1) \text{ord } \mathbf{m}]_{(m'_{0,n_0})} & [\lambda_{j,n_j} + m_{j,n_j}]_{(m'_{j,n_j})} \end{array} \right\},$$

*the Fuchsian operator  $P'P$  has the spectral type  $\mathbf{m} + \mathbf{m}'$  and the Riemann scheme*

$$(6.50) \quad \left\{ \begin{array}{cccc} x = c_0 = \infty & c_1 & \cdots & c_p \\ [\lambda_{0,1}]_{(m_{0,1} + m'_{0,1})} & [\lambda_{1,1}]_{(m_{1,1} + m'_{1,1})} & \cdots & [\lambda_{p,1}]_{(m_{p,1} + m'_{p,1})} \\ \vdots & \vdots & \vdots & \vdots \\ [\lambda_{0,n_0}]_{(m_{0,n_0} + m'_{0,n_0})} & [\lambda_{1,n_1}]_{(m_{1,n_1} + m'_{1,n_1})} & \cdots & [\lambda_{p,n_p}]_{(m_{p,n_p} + m'_{p,n_p})} \end{array} \right\}.$$

*Suppose the Fuchs relation (6.32) for (6.15). Then the Fuchs relation for (6.49) is valid if and only if so is the Fuchs relation for (6.50).*

ii) *For  $Q = \sum_{k \geq 0} q_k(x) \partial^k \in W(x)$ , we define*

$$(6.51) \quad Q^* := \sum_{k \geq 0} (-\partial)^k q_k(x)$$

*and the dual operator  $P^\vee$  of  $P$  by*

$$(6.52) \quad P^\vee := a_n(x)(a_n(x)^{-1}P)^*$$

*when  $P = \sum_{k=0}^n a_k(x) \partial^k$ . Then the Riemann scheme of  $P^\vee$  equals*

$$(6.53) \quad \left\{ \begin{array}{cc} x = c_0 = \infty & c_j \quad (j = 1, \dots, p) \\ [2 - n - m_{0,1} - \lambda_{0,1}]_{(m_{0,1})} & [n - m_{j,1} - \lambda_{j,1}]_{(m_{j,1})} \\ \vdots & \vdots \\ [2 - n - m_{0,n_0} - \lambda_{0,n_0}]_{(m_{0,n_0})} & [n - m_{j,n_j} - \lambda_{j,n_j}]_{(m_{j,n_j})} \end{array} \right\}.$$

*Proof.* i) It is clear that  $P'P$  is a Fuchsian differential operator of the normal form if so is  $P'$  and Lemma 6.5 iii) shows that the characteristic exponents of  $P'P$  at  $x = c_j$  for  $j = 1, \dots, p$  are just as given in the Riemann scheme (6.50). Put  $n = \text{ord } \mathbf{m}$  and  $n' = \mathbf{m}'$ . We can also apply Lemma 6.5 iii) to  $x^{-(p-1)n}P$  and  $x^{-(p-1)n'}P'$  under the coordinate transformation  $x \mapsto \frac{1}{x}$ , we have the set of characteristic exponents as is given in (6.50) because  $x^{-(p-1)(n+n')}P'P = (\text{Ad}(x^{-(p-1)n})x^{-(p-1)n'}P')(x^{-(p-1)n}P)$ .

The Fuchs relation for (6.49) equals

$$\sum_{j=0}^p \sum_{\nu=1}^{n_j} m'_{j,\nu} (\lambda_{j,\nu} + m_{j,\nu} - \delta_{j,0}(p-1) \text{ord } \mathbf{m}) = \text{ord } \mathbf{m}' - \frac{\text{idx } \mathbf{m}'}{2}.$$

Since

$$\sum_{j=0}^p \sum_{\nu=1}^{n_j} m'_{j,\nu} (m_{j,\nu} - \delta_{j,0}(p-1) \text{ord } \mathbf{m}) = \text{idx}(\mathbf{m}, \mathbf{m}'),$$

the condition is equivalent to

$$(6.54) \quad \sum_{j=0}^p \sum_{\nu=1}^{n_j} m'_{j,\nu} \lambda_{j,\nu} = \text{ord } \mathbf{m}' - \frac{\text{idx } \mathbf{m}}{2} - \text{idx}(\mathbf{m}, \mathbf{m}')$$

and also to

$$(6.55) \quad \sum_{j=0}^p \sum_{\nu=1}^{n_j} (m_{j,\nu} + m'_{j,\nu}) \lambda_{j,\nu} = \text{ord}(\mathbf{m} + \mathbf{m}') - \frac{\text{id}x(\mathbf{m} + \mathbf{m}')}{2}$$

under the condition (6.32).

ii) We may suppose  $c_1 = 0$ . Then

$$\begin{aligned} a_n(x)^{-1}P &= \sum_{\ell \geq 0} x^{\ell-n} q_\ell(\vartheta) \prod_{\substack{1 \leq \nu \leq n_1 \\ 0 \leq i < m_{1,\nu} - \ell}} (\vartheta - \lambda_{1,\nu} - i), \\ a_n(x)^{-1}P^\vee &= \sum_{\ell \geq 0} q_\ell(-\vartheta - 1) \prod_{\substack{1 \leq \nu \leq n_1 \\ 0 \leq i < m_{1,\nu} - \ell}} (-\vartheta - \lambda_{1,\nu} - i - 1) x^{\ell-n} \\ &= \sum_{\ell \geq 0} x^{\ell-n} s_\ell(\vartheta) \prod_{\substack{1 \leq \nu \leq n_1 \\ 0 \leq i < m_{1,\nu} - \ell}} (\vartheta + \lambda_{1,\nu} + i + 1 + \ell - n) \\ &= \sum_{\ell \geq 0} x^{\ell-n} s_\ell(\vartheta) \prod_{\substack{1 \leq \nu \leq n_1 \\ 0 \leq j < m_{1,\nu} - \ell}} (\vartheta + \lambda_{1,\nu} - j + m_{1,\nu} - n) \end{aligned}$$

with suitable polynomials  $q_\ell$  and  $s_\ell$  such that  $q_0, s_0 \in \mathbb{C}^\times$ . Hence the set of characteristic exponents of  $P^\vee$  at  $c_1$  is  $\{[n - m_{1,\nu} - \lambda_{1,\nu}]_{(m_{1,\nu})}; \nu = 1, \dots, n_1\}$ .

At infinity we have

$$\begin{aligned} a_n(x)^{-1}P &= \sum_{\ell \geq 0} x^{-\ell-n} q_\ell(\vartheta) \prod_{\substack{1 \leq \nu \leq n_1 \\ 0 \leq i < m_{0,\nu} - \ell}} (\vartheta + \lambda_{0,\nu} + i), \\ (a_n(x)^{-1}P)^* &= \sum_{\ell \geq 0} x^{-\ell-n} s_\ell(\vartheta) \prod_{\substack{1 \leq \nu \leq n_0 \\ 0 \leq i < m_{0,\nu} - \ell}} (\vartheta - \lambda_{0,\nu} - i + 1 - \ell - n) \\ &= \sum_{\ell \geq 0} x^{-\ell-n} s_\ell(\vartheta) \prod_{\substack{1 \leq \nu \leq n_1 \\ 0 \leq j < m_{0,\nu} - \ell}} (\vartheta - \lambda_{0,\nu} + j + 2 - n - m_{0,\nu}) \end{aligned}$$

with suitable polynomials  $q_\ell$  and  $s_\ell$  with  $q_0, s_0 \in \mathbb{C}^\times$  and the set of characteristic exponents of  $P^\vee$  at  $c_1$  is  $\{[2 - n - m_{0,\nu} - \lambda_{0,\nu}]_{(m_{0,\nu})}; \nu = 1, \dots, n_0\}$   $\square$

**Example 6.20.** The Riemann scheme of the dual  $P_{\lambda_1, \dots, \lambda_p, \mu}^\vee$  of Jordan-Pochhammer operator  $P_{\lambda_1, \dots, \lambda_p, \mu}^\vee$  given in Example 2.8 iii) is

$$\left\{ \begin{array}{cccc} \frac{1}{c_1} & \cdots & \frac{1}{c_p} & \infty \\ [1]_{(p-1)} & \cdots & [1]_{(p-1)} & [2 - 2p + \mu]_{(p-1)} \\ \lambda_1 - \mu + p - 1 & \cdots & -\lambda_p - \mu + p - 1 & \lambda_1 + \cdots + \lambda_p + \mu - p + 1 \end{array} \right\}.$$

## 7. REDUCTION OF FUCHSIAN DIFFERENTIAL EQUATIONS

Additions and middle convolutions introduced in §2 are transformations within Fuchsian differential operators and we examine how their Riemann schemes change under the transformations.

**Proposition 7.1.** i) Let  $Pu = 0$  be a Fuchsian differential equation. Suppose there exists  $c \in \mathbb{C}$  such that  $P \in (\partial - c)W[x]$ . Then  $c = 0$ .

ii) For  $\phi(x) \in \mathbb{C}(x)$ ,  $\lambda \in \mathbb{C}$ ,  $\mu \in \mathbb{C}$  and  $P \in W[x]$ , we have

$$(7.1) \quad P \in \mathbb{C}[x] \text{RA} \text{dei}(-\phi(x)) \circ \text{RA} \text{dei}(\phi(x)) P,$$

$$(7.2) \quad P \in \mathbb{C}[\partial] \text{RAd}(\partial^{-\mu}) \circ \text{RAd}(\partial^\mu) P.$$



In particular, if the equation  $Pu = 0$  is irreducible and  $\text{ord } P > 1$ ,  $\text{RAd}(\partial^{-\mu}) \circ \text{RAd}(\partial^\mu)P = cP$  with  $c \in \mathbb{C}^\times$ .

*Proof.* i) Put  $P = (\partial - c)Q$ . Then there is a function  $u(x)$  satisfying  $Qu(x) = e^{cx}$ . Since  $Pu = 0$  has at most a regular singularity at  $x = \infty$ , there exist  $C > 0$  and  $N > 0$  such that  $|u(x)| < C|x|^N$  for  $|x| \gg 1$  and  $0 \leq \arg x \leq 2\pi$ , which implies  $c = 0$ .

ii) This follows from the fact

$$\begin{aligned} \text{Adei}(-\phi(x)) \circ \text{Adei}(\phi(x)) &= \text{id}, \\ \text{Adei}(\phi(x))f(x)P &= f(x)\text{Adei}(\phi(x))P \quad (f(x) \in \mathbb{C}(x)) \end{aligned}$$

and the definition of  $\text{RAdei}(\phi(x))$  and  $\text{RAd}(\partial^\mu)$ .  $\square$

The addition and the middle convolution transform the Riemann scheme of the Fuchsian differential equation as follows.

**Theorem 7.2.** *Let  $Pu = 0$  be a Fuchsian differential equation with the Riemann scheme (6.15). We assume that  $P$  has the normal form (6.43).*

i) (addition) *The operator  $\text{Ad}((x - c_j)^\tau)P$  has the Riemann scheme*

$$\left\{ \begin{array}{cccccc} x = c_0 = \infty & c_1 & \cdots & c_j & \cdots & c_p \\ [\lambda_{0,1} - \tau]_{(m_{0,1})} & [\lambda_{1,1}]_{(m_{1,1})} & \cdots & [\lambda_{j,1} + \tau]_{(m_{j,1})} & \cdots & [\lambda_{p,1}]_{(m_{p,1})} \\ \vdots & \vdots & \vdots & \vdots & \vdots & \vdots \\ [\lambda_{0,n_0} - \tau]_{(m_{0,n_0})} & [\lambda_{1,n_1}]_{(m_{1,n_1})} & \cdots & [\lambda_{j,n_j} + \tau]_{(m_{j,n_j})} & \cdots & [\lambda_{p,n_p}]_{(m_{p,n_p})} \end{array} \right\}.$$

ii) (middle convolution) *Fix  $\mu \in \mathbb{C}$ . By allowing the condition  $m_{j,1} = 0$ , we may assume*

$$(7.3) \quad \mu = \lambda_{0,1} - 1 \quad \text{and} \quad \lambda_{j,1} = 0 \quad \text{for } j = 1, \dots, p$$

and  $\#\{j; m_{j,1} < n\} \geq 2$  and  $P$  is of the normal form (6.43). Putting

$$(7.4) \quad d := \sum_{j=0}^p m_{j,1} - (p-1)n,$$

we suppose

$$(7.5) \quad m_{j,1} \geq d \quad \text{for } j = 0, \dots, p,$$

$$(7.6) \quad \left\{ \begin{array}{l} \lambda_{0,\nu} \notin \{0, -1, -2, \dots, m_{0,1} - m_{0,\nu} - d + 2\} \\ \text{if } m_{0,\nu} + \cdots + m_{p,1} - (p-1)n \geq 2, \quad m_{1,1} \cdots m_{p,1} \neq 0 \quad \text{and } \nu \geq 1, \end{array} \right.$$

$$(7.7) \quad \left\{ \begin{array}{l} \lambda_{0,1} + \lambda_{j,\nu} \notin \{0, -1, -2, \dots, m_{j,1} - m_{j,\nu} - d + 2\} \\ \text{if } m_{0,1} + \cdots + m_{j-1,1} + m_{j,\nu} + m_{j+1,1} + \cdots + m_{p,1} - (p-1)n \geq 2, \\ m_{j,1} \neq 0, \quad 1 \leq j \leq p \quad \text{and } \nu \geq 2. \end{array} \right.$$

Then  $S := \partial^{-d} \text{Ad}(\partial^{-\mu}) \prod_{j=1}^p (x - c_j)^{-m_{j,1}} P \in W[x]$  and the Riemann scheme of  $S$  equals

$$(7.8) \quad \left\{ \begin{array}{cccc} x = c_0 = \infty & c_1 & \cdots & c_p \\ [1 - \mu]_{(m_{0,1}-d)} & [0]_{(m_{1,1}-d)} & \cdots & [0]_{(m_{p,1}-d)} \\ [\lambda_{0,2} - \mu]_{(m_{0,2})} & [\lambda_{1,2} + \mu]_{(m_{1,2})} & \cdots & [\lambda_{p,2} + \mu]_{(m_{p,2})} \\ \vdots & \vdots & \vdots & \vdots \\ [\lambda_{0,n_0} - \mu]_{(m_{0,n_0})} & [\lambda_{1,n_1} + \mu]_{(m_{1,n_1})} & \cdots & [\lambda_{p,n_p} + \mu]_{(m_{p,n_p})} \end{array} \right\}.$$

More precisely, the condition (7.5) and the condition (7.6) for  $\nu = 1$  assure  $S \in W[x]$ . In this case the condition (7.6) (resp. (7.7) for a fixed  $j$ ) assures that the sets of characteristic exponents of  $P$  at  $x = \infty$  (resp.  $c_j$ ) are equal to the sets given in (7.8), respectively.

Here we have  $\text{RAd}(\partial^{-\mu})\text{R}P = S$ , if

$$(7.9) \quad \begin{cases} \lambda_{j,1} + m_{j,1} & \text{are not characteristic exponents of } P \\ & \text{at } x = c_j \text{ for } j = 0, \dots, p, \text{ respectively,} \end{cases}$$

and moreover

$$(7.10) \quad m_{0,1} = d \text{ or } \lambda_{0,1} \notin \{-d, -d-1, \dots, 1-m_{0,1}\}.$$

Using the notation in Definition 2.3, we have

$$(7.11) \quad \begin{aligned} S &= \text{Ad}((x-c_1)^{\lambda_{0,1}-2})(x-c_1)^d T_{\frac{1}{x-c_1}}^* (-\partial)^{-d} \text{Ad}(\partial^{-\mu}) T_{\frac{1}{x}+c_1}^* \\ &\cdot (x-c_1)^d \prod_{j=1}^p (x-c_j)^{-m_{j,1}} \text{Ad}((x-c_1)^{\lambda_{0,1}}) P \end{aligned}$$

under the conditions (7.5) and

$$(7.12) \quad \begin{cases} \lambda_{0,\nu} \notin \{0, -1, -2, \dots, m_{0,1} - m_{0,\nu} - d + 2\} \\ \text{if } m_{0,\nu} + \dots + m_{p,1} - (p-1)n \geq 2, m_{1,1} \neq 0 \text{ and } \nu \geq 1. \end{cases}$$

iii) Suppose  $\text{ord } P > 1$  and  $P$  is irreducible in ii). Then the conditions (7.5), (7.6), (7.7) are valid. The condition (7.10) is also valid if  $d \geq 1$ .

All these conditions in ii) are valid if  $\#\{j; m_{j,1} < n\} \geq 2$  and  $\mathbf{m}$  is realizable and moreover  $\lambda_{j,\nu}$  are generic under the Fuchs relation with  $\lambda_{j,1} = 0$  for  $j = 1, \dots, p$ .

iv) Let  $\mathbf{m} = (m_{j,\nu})_{\substack{j=0,\dots,p \\ \nu=1,\dots,n_j}} \in \mathcal{P}_{p+1}^{(n)}$ . Define  $d$  by (7.4). Suppose  $\lambda_{j,\nu}$  are complex numbers satisfying (7.3). Suppose moreover  $m_{j,1} \geq d$  for  $j = 1, \dots, p$ . Defining  $\mathbf{m}' \in \mathcal{P}_{p+1}^{(n)}$  and  $\lambda'_{j,\nu}$  by

$$(7.13) \quad m'_{j,\nu} = m_{j,\nu} - \delta_{\nu,1}d \quad (j = 0, \dots, p, \nu = 1, \dots, n_j),$$

$$(7.14) \quad \lambda'_{j,\nu} = \begin{cases} 2 - \lambda_{0,1} & (j = 0, \nu = 1), \\ \lambda_{j,\nu} - \lambda_{0,1} + 1 & (j = 0, \nu > 1), \\ 0 & (j > 0, \nu = 1), \\ \lambda_{j,\nu} + \lambda_{0,1} - 1 & (j > 0, \nu > 1), \end{cases}$$

we have

$$(7.15) \quad \text{idx } \mathbf{m} = \text{idx } \mathbf{m}', \quad |\{\lambda_{\mathbf{m}}\}| = |\{\lambda'_{\mathbf{m}'}\}|.$$

*Proof.* The claim i) is clear from the definition of the Riemann scheme.

ii) Suppose (7.5), (7.6) and (7.7). Then

$$(7.16) \quad P' := \left( \prod_{j=1}^p (x-c_j)^{-m_{j,1}} \right) P \in W[x].$$

Note that  $\text{R}P = P'$  under the condition (7.9). Put  $Q := \partial^{(p-1)n - \sum_{j=1}^p m_{j,1}} P'$ . Here we note that (7.5) assures  $(p-1)n - \sum_{j=1}^p m_{j,1} \geq 0$ .

Fix a positive integer  $j$  with  $j \leq p$ . For simplicity suppose  $j = 1$  and  $c_j = 0$ . Since  $P' = \sum_{j=0}^n a_j(x)\partial^j$  with  $\deg a_j(x) \leq (p-1)n + j - \sum_{j=1}^p m_{j,1}$ , we have

$$x^{m_{1,1}} P' = \sum_{\ell=0}^N x^{N-\ell} r_{\ell}(\vartheta) \prod_{\substack{1 \leq \nu \leq n_0 \\ 0 \leq i < m_{0,\nu} - \ell}} (\vartheta + \lambda_{0,\nu} + i)$$

and

$$N := (p-1)n - \sum_{j=2}^p m_{j,1} = m_{0,1} + m_{1,1} - d$$

with suitable polynomials  $r_\ell$  such that  $r_0 \in \mathbb{C}^\times$ . Suppose

$$(7.17) \quad \prod_{\substack{1 \leq \nu \leq n_0 \\ 0 \leq i < m_{0,\nu} - \ell}} (\vartheta + \lambda_{0,\nu} + i) \notin xW[x] \text{ if } N - m_{1,1} + 1 \leq \ell \leq N.$$

Since  $P' \in W[x]$ , we have

$$x^{N-\ell} r_\ell(\vartheta) = x^{N-\ell} x^{\ell-N+m_{1,1}} \partial^{\ell-N+m_{1,1}} s_\ell(\vartheta) \text{ if } N - m_{1,1} + 1 \leq \ell \leq N$$

for suitable polynomials  $s_\ell$ . Putting  $s_\ell = r_\ell$  for  $0 \leq \ell \leq N - m_{1,1}$ , we have

$$(7.18) \quad \begin{aligned} P' &= \sum_{\ell=0}^{N-m_{1,1}} x^{N-m_{1,1}-\ell} s_\ell(\vartheta) \prod_{\substack{1 \leq \nu \leq n_0 \\ 0 \leq i < m_{0,\nu} - \ell}} (\vartheta + \lambda_{0,\nu} + i) \\ &+ \sum_{\ell=N-m_{1,1}+1}^N \partial^{\ell-N+m_{1,1}} s_\ell(\vartheta) \prod_{\substack{1 \leq \nu \leq n_0 \\ 0 \leq i < m_{0,\nu} - \ell}} (\vartheta + \lambda_{0,\nu} + i). \end{aligned}$$

Note that  $s_0 \in \mathbb{C}^\times$  and the condition (7.17) is equivalent to the condition  $\lambda_{0,\nu} + i \neq 0$  for any  $\nu$  and  $i$  such that there exists an integer  $\ell$  with  $0 \leq i \leq m_{0,\nu} - \ell - 1$  and  $N - m_{1,1} + 1 \leq \ell \leq N$ . This condition is valid if (7.6) is valid, namely,  $m_{1,1} = 0$  or

$$\lambda_{0,\nu} \notin \{0, -1, \dots, m_{0,1} - m_{0,\nu} - d + 2\}$$

for  $\nu$  satisfying  $m_{0,\nu} \geq m_{0,1} - d + 2$ . Under this condition we have

$$\begin{aligned} Q &= \sum_{\ell=0}^N \partial^\ell s_\ell(\vartheta) \prod_{1 \leq i \leq N-m_{1,1}-\ell} (\vartheta + i) \cdot \prod_{\substack{1 \leq \nu \leq n_0 \\ 0 \leq i < m_{0,\nu} - \ell}} (\vartheta + \lambda_{0,\nu} + i), \\ \text{Ad}(\partial^{-\mu})Q &= \sum_{\ell=0}^N \partial^\ell s_\ell(\vartheta - \mu) \prod_{1 \leq i \leq N-m_{1,1}-\ell} (\vartheta - \mu + i) \\ &\cdot \prod_{1 \leq i \leq m_{0,1}-\ell} (\vartheta + i) \cdot \prod_{\substack{2 \leq \nu \leq n_0 \\ 0 \leq i < m_{0,\nu} - \ell}} (\vartheta - \mu + \lambda_{0,\nu} + i) \end{aligned}$$

since  $\mu = \lambda_{0,1} - 1$ . Hence  $\partial^{-m_{0,1}} \text{Ad}(\partial^{-\mu})Q$  equals

$$\begin{aligned} &\sum_{\ell=0}^{m_{0,1}-1} x^{m_{0,1}-\ell} s_\ell(\vartheta - \mu) \prod_{1 \leq i \leq N-m_{1,1}-\ell} (\vartheta - \mu + i) \prod_{\substack{2 \leq \nu \leq n_0 \\ 0 \leq i < m_{0,\nu} - \ell}} (\vartheta - \mu + \lambda_{0,\nu} + i) \\ &+ \sum_{\ell=m_{0,1}}^N \partial^{\ell-m_{0,1}} s_\ell(\vartheta - \mu) \prod_{1 \leq i \leq N-m_{1,1}-\ell} (\vartheta - \mu + i) \prod_{\substack{2 \leq \nu \leq n_0 \\ 0 \leq i < m_{0,\nu} - \ell}} (\vartheta - \mu + \lambda_{0,\nu} + i) \end{aligned}$$

and then the set of characteristic exponents of this operator at  $\infty$  is

$$\{[1 - \mu]_{(m_{0,1}-d)}, [\lambda_{0,2} - \mu]_{(m_{0,2})}, \dots, [\lambda_{0,n_0} - \mu]_{(m_{0,n_0})}\}.$$

Moreover  $\partial^{-m_{0,1}-1} \text{Ad}(\partial^{-\mu})Q \notin W[x]$  if  $\lambda_{0,1} + m_{0,1}$  is not a characteristic exponent of  $P$  at  $\infty$  and  $-\lambda_{0,1} + 1 + i \neq m_{0,1} + 1$  for  $1 \leq i \leq N - m_{1,1} = m_{0,1} - d$ , which assures  $x^{m_{0,1}} s_0 \prod_{1 \leq i \leq N-m_{1,1}} (\vartheta - \mu + i) \prod_{\substack{2 \leq \nu \leq n_0 \\ 0 \leq i < m_{0,\nu}}} (\vartheta - \mu + \lambda_{1,\nu} + i) \notin \partial W[x]$ .

Similarly we have

$$\begin{aligned}
P' &= \sum_{\ell=0}^{m_{1,1}} \partial^{m_{1,1}-\ell} q_{\ell}(\vartheta) \prod_{\substack{2 \leq \nu \leq n_1 \\ 0 \leq i < m_{1,\nu}-\ell}} (\vartheta - \lambda_{1,\nu} - i) \\
&+ \sum_{\ell=m_{1,1}+1}^N x^{\ell-m_{1,1}} q_{\ell}(\vartheta) \prod_{\substack{2 \leq \nu \leq n_1 \\ 0 \leq i < m_{1,\nu}-\ell}} (\vartheta - \lambda_{1,\nu} - i), \\
Q &= \sum_{\ell=0}^{m_{1,1}} \partial^{N-\ell} q_{\ell}(\vartheta) \prod_{\substack{2 \leq \nu \leq n_1 \\ 0 \leq i < m_{1,\nu}-\ell}} (\vartheta + \lambda_{1,\nu} - i) \\
&+ \sum_{\ell=m_{1,1}+1}^N \partial^{N-\ell} q_{\ell}(\vartheta) \prod_{i=1}^{\ell-m_{1,1}} (\vartheta + i) \prod_{\substack{2 \leq \nu \leq n_1 \\ 0 \leq i < m_{1,\nu}-\ell}} (\vartheta - \lambda_{1,\nu} - i). \\
\text{Ad}(\partial^{-\mu})Q &= \sum_{\ell=0}^N \partial^{N-\ell} q_{\ell}(\vartheta - \mu) \prod_{1 \leq i \leq \ell-m_{1,1}} (\vartheta - \mu + i) \\
&\cdot \prod_{\substack{2 \leq \nu \leq n_1 \\ 0 \leq i < m_{1,\nu}-\ell}} (\vartheta - \mu - \lambda_{1,\nu} - i)
\end{aligned}$$

with  $q_0 \in \mathbb{C}^{\times}$ . Then the set of characteristic exponents of  $\partial^{-m_{0,1}} \text{Ad}(p^{-\mu})Q$  equals

$$\{[0]_{(m_{1,1}-d)}, [\lambda_{1,2} + \mu]_{(m_{1,2})}, \dots, [\lambda_{1,n_1} + \mu]_{(m_{1,n_1})}\}$$

if

$$\prod_{\substack{2 \leq \nu \leq n_1 \\ 0 \leq i < m_{1,\nu}-\ell}} (\vartheta - \mu - \lambda_{1,\nu} - i) \notin \partial W[x]$$

for any integers  $\ell$  satisfying  $0 \leq \ell \leq N$  and  $N - \ell < m_{0,1}$ . This condition is satisfied if (7.7) is valid, namely,  $m_{0,1} = 0$  or

$$\begin{aligned}
\lambda_{0,1} + \lambda_{1,\nu} &\notin \{0, -1, \dots, m_{1,1} - m_{1,\nu} - d + 2\} \\
&\text{for } \nu \geq 2 \text{ satisfying } m_{1,\nu} \geq m_{1,1} - d + 2
\end{aligned}$$

because  $m_{1,\nu} - \ell - 1 \leq m_{1,\nu} + m_{0,1} - N - 2 = m_{1,\nu} - m_{1,1} + d - 2$  and the condition  $\vartheta - \mu - \lambda_{1,\nu} - i \in \partial W[x]$  means  $-1 = \mu + \lambda_{1,\nu} + i = \lambda_{0,1} - 1 + \lambda_{1,\nu} + i$ .

Now we will prove (7.11). Under the conditions, it follows from (7.18) that

$$\begin{aligned}
\tilde{P} &:= x^{m_{0,1}-N} \text{Ad}(x^{\lambda_{0,1}}) \prod_{j=2}^p (x - c_j)^{-m_{j,1}} P \\
&= x^{m_{0,1}+m_{1,1}-N} \text{Ad}(x^{\lambda_{0,1}}) P' \\
&= \sum_{\ell=0}^N x^{m_{0,1}-\ell} \text{Ad}(x^{\lambda_{0,1}}) s_{\ell}(\vartheta) \prod_{0 \leq \nu < \ell - N + m_{1,1}} (\vartheta - \nu) \prod_{\substack{1 \leq \nu \leq n_0 \\ 0 \leq i < m_{0,\nu}-\ell}} (\vartheta + \lambda_{0,\nu} + i),
\end{aligned}$$

$$\begin{aligned}
\tilde{Q} &:= (-\partial)^{N-m_{0,1}} T_{\frac{1}{x}}^* \tilde{P} \\
&= (-\partial)^{N-m_{0,1}} \sum_{\ell=0}^N x^{\ell-m_{0,1}} s_{\ell}(-\vartheta - \lambda_{0,1}) \prod_{0 \leq \nu < \ell - N + m_{1,1}} (-\vartheta - \lambda_{0,1} - \nu) \\
&\cdot \prod_{\substack{2 \leq \nu \leq n_0 \\ 0 \leq i < m_{0,\nu}-\ell}} (-\vartheta + \lambda_{0,\nu} - \lambda_{0,1} + i) \prod_{0 \leq i \leq m_{0,1}-\ell} (-\vartheta + i)
\end{aligned}$$

$$\begin{aligned}
&= \sum_{\ell=0}^N (-\partial)^{N-\ell} s_{\ell}(-\vartheta - \lambda_{0,1}) \prod_{1 \leq i \leq \ell - m_{0,1}} (-\vartheta - i) \\
&\quad \cdot \prod_{0 \leq \nu < \ell - N + m_{1,1}} (-\vartheta - \lambda_{0,1} - \nu) \prod_{\substack{2 \leq \nu \leq n_0 \\ 0 \leq i < m_{0,\nu} - \ell}} (-\vartheta + \lambda_{0,\nu} - \lambda_{0,1} + i)
\end{aligned}$$

and therefore

$$\begin{aligned}
\text{Ad}(\partial^{-\mu})\tilde{Q} &= \sum_{\ell=0}^N (-\partial)^{N-\ell} s_{\ell}(-\vartheta - 1) \prod_{1 \leq i \leq \ell - m_{0,1}} (-\vartheta + \lambda_{0,1} - 1 - i) \\
&\quad \cdot \prod_{0 \leq \nu < \ell - N + m_{1,1}} (-\vartheta - 1 - \nu) \prod_{\substack{2 \leq \nu \leq n_0 \\ 0 \leq i < m_{0,\nu} - \ell}} (-\vartheta + \lambda_{0,\nu} - 1 + i).
\end{aligned}$$

Since

$$\begin{aligned}
(-\partial)^{N-\ell-m_{1,1}} \prod_{0 \leq \nu < \ell - N + m_{1,1}} (-\vartheta - 1 - \nu) &= \begin{cases} x^{\ell-N+m_{1,1}} & (N-\ell < m_{1,1}), \\ (-\partial)^{N-\ell-m_{1,1}} & (N-\ell \geq m_{1,1}), \end{cases} \\
&= x^{\ell-N+m_{1,1}} \prod_{0 \leq \nu < N-\ell-m_{1,1}} (-\vartheta + \nu),
\end{aligned}$$

we have

$$\begin{aligned}
\tilde{Q}' &:= (-\partial)^{-m_{1,1}} \text{Ad}(\partial^{-\mu})\tilde{Q} = \sum_{\ell=0}^N x^{\ell-N+m_{1,1}} \prod_{0 \leq \nu < N-\ell-m_{1,1}} (-\vartheta + \nu) \\
&\quad \cdot s_{\ell}(-\vartheta - 1) \prod_{0 \leq \nu < \ell - m_{0,1}} (-\vartheta + \lambda_{0,1} - 2 - \nu) \prod_{\substack{2 \leq \nu \leq n_0 \\ 0 \leq i < m_{0,\nu} - \ell}} (-\vartheta + \lambda_{0,\nu} - 1 + i)
\end{aligned}$$

and

$$\begin{aligned}
x^{m_{0,1}+m_{1,1}-N} \text{Ad}(x^{\lambda_{0,1}-2})T_{\frac{x}{x}}^* \tilde{Q}' &= \sum_{\ell=0}^N x^{m_{0,1}-\ell} \prod_{0 \leq \nu < \ell - m_{0,1}} (\vartheta - \nu) \cdot s_{\ell}(\vartheta - \lambda_{0,1} + 1) \\
&\quad \cdot \prod_{0 \leq \nu < N - m_{1,1} - \ell} (\vartheta - \lambda_{0,1} + 2 + \nu) \prod_{\substack{2 \leq \nu \leq n_0 \\ 0 \leq i < m_{0,\nu} - \ell}} (\vartheta + \lambda_{0,\nu} - \lambda_{0,1} + 1 + i),
\end{aligned}$$

which equals  $\partial^{-m_{0,1}} \text{Ad}(\partial^{-\mu})Q$  because  $\prod_{0 \leq \nu < k} (\vartheta - \nu) = x^k \partial^k$  for  $k \in \mathbb{Z}_{\geq 0}$ .

iv) (Cf. Remark 9.4 ii) for another proof.) Since

$$\begin{aligned}
\text{idx } \mathbf{m} - \text{idx } \mathbf{m}' &= \sum_{j=0}^p m_{j,1}^2 - (p-1)n^2 - \sum_{j=0}^p (m_{j,1} - d)^2 + (p-1)(n-d)^2 \\
&= 2d \sum_{j=0}^p m_{j,1} - (p+1)d^2 - 2(p-1)nd + (p-1)d^2 \\
&= d \left( 2 \sum_{j=0}^p m_{j,1} - 2d - 2(p-1)n \right) = 0
\end{aligned}$$

and

$$\sum_{j=0}^p \sum_{\nu=1}^{n_j} m_{j,\nu} \lambda_{j,\nu} - \sum_{j=0}^p \sum_{\nu=1}^{n_j} m'_{j,\nu} \lambda'_{j,\nu}$$

$$\begin{aligned}
&= m_{0,1}(\mu + 1) - (m_{0,1} - d)(1 - \mu) + \mu(n - m_{0,1} - \sum_{j=1}^p (n - m_{j,1})) \\
&= \left( \sum_{j=0}^p m_{j,1} - d - (p-1)n \right) \mu - m_{0,1}d - (m_{0,1} - d) = d,
\end{aligned}$$

we have the claim.

The claim iii) follows from the following lemma when  $P$  is irreducible.

Suppose  $\lambda_{j,\nu}$  are generic in the sense of the claim iii). Put  $\mathbf{m} = \gcd(\mathbf{m})\overline{\mathbf{m}}$ . Then an irreducible subspace of the solutions of  $Pu = 0$  has the spectral type  $\ell'\overline{\mathbf{m}}$  with  $1 \leq \ell' \leq \gcd(\mathbf{m})$  and the same argument as in the proof of the following lemma shows iii).  $\square$

The following lemma is known which follows from Scott's lemma (cf. §7.19).

**Lemma 7.3.** *Let  $P$  be a Fuchsian differential operator with the Riemann scheme (6.15). Suppose  $P$  is irreducible. Then*

$$(7.19) \quad \text{idx } \mathbf{m} \leq 2.$$

Fix  $\ell = (\ell_0, \dots, \ell_p) \in \mathbb{Z}_{>0}^{p+1}$  and suppose  $\text{ord } P > 1$ . Then

$$(7.20) \quad m_{0,\ell_0} + m_{1,\ell_1} + \dots + m_{p,\ell_p} - (p-1) \text{ord } \mathbf{m} \leq m_{k,\ell_k} \quad \text{for } k = 0, \dots, p.$$

Moreover the condition

$$(7.21) \quad \lambda_{0,\ell_0} + \lambda_{1,\ell_1} + \dots + \lambda_{p,\ell_p} \in \mathbb{Z}$$

implies

$$(7.22) \quad m_{0,\ell_0} + m_{1,\ell_1} + \dots + m_{p,\ell_p} \leq (p-1) \text{ord } \mathbf{m}.$$

*Proof.* Let  $M_j$  be the monodromy generators of the solutions of  $Pu = 0$  at  $c_j$ , respectively. Then  $\dim Z(M_j) \geq \sum_{\nu=1}^{n_j} m_{j,\nu}^2$  and therefore  $\sum_{j=0}^p \text{codim } Z(M_j) \leq (p+1)n^2 - (\text{idx } \mathbf{m} + (p-1)n^2) = 2n^2 - \text{idx } \mathbf{m}$ . Hence Corollary 11.12 (cf. (11.47)) proves (7.19).

We may assume  $\ell_j = 1$  for  $j = 0, \dots, p$  and  $k = 0$  to prove the lemma. By the map  $u(x) \mapsto \prod_{j=1}^p (x - c_j)^{-\lambda_{j,1}} u(x)$  we may moreover assume  $\lambda_{j,\ell_j} = 0$  for  $j = 1, \dots, p$ . Suppose  $\lambda_{0,1} \in \mathbb{Z}$ . We may assume  $M_p \cdots M_1 M_0 = I_n$ . Since  $\dim \ker M_j \geq m_{j,1}$ , Scott's lemma (Lemma 11.11) assures (7.22).

The condition (7.20) is reduced to (7.22) by putting  $m_{0,\ell_0} = 0$  and  $\lambda_{0,\ell_0} = -\lambda_{1,\ell_1} - \dots - \lambda_{p,\ell_p}$  because we may assume  $k = 0$  and  $\ell_0 = n_0 + 1$ .  $\square$

*Remark 7.4.* i) Retain the notation in Theorem 7.2. The operation in Theorem 7.2 i) corresponds to the *addition* and the operation in Theorem 7.2 ii) corresponds to Katz's *middle convolution* (cf. [Kz]), which are studied by [DR] for the systems of Schlesinger canonical form.

The operation  $c(P) := \text{Ad}(\partial^{-\mu})\partial^{(p-1)n}P$  is always well-defined for the Fuchsian differential operator of the normal form which has  $p+1$  singular points including  $\infty$ . This corresponds to the *convolution* defined by Katz. Note that the equation  $Sv = 0$  is a quotient of the equation  $c(P)\tilde{u} = 0$ .

ii) Retain the notation in the previous theorem. Suppose the equation  $Pu = 0$  is irreducible and  $\lambda_{j,\nu}$  are generic complex numbers satisfying the assumption in Theorem 7.2. Let  $u(x)$  be a local solution of the equation  $Pu = 0$  corresponding to the characteristic exponent  $\lambda_{i,\nu}$  at  $x = c_i$ . Assume  $0 \leq i \leq p$  and  $1 < \nu \leq n_i$ . Then the irreducible equations  $(\text{Ad}((x - c_j)^r)P)u_1 = 0$  and  $(\text{RAd}(\partial^{-\mu}) \circ \text{R}P)u_2 = 0$  are characterized by the equations satisfied by  $u_1(x) = (x - c_j)^r u(x)$  and  $u_2(x) = I_{c_i}^\mu(u(x))$ , respectively.

Moreover for any integers  $k_0, k_1, \dots, k_p$  the irreducible equation  $Qu_3 = 0$  satisfied by  $u_3(x) = I_{c_i}^{\mu+k_0} \left( \prod_{j=1}^p (x-c_j)^{k_j} u(x) \right)$  is isomorphic to the equation  $(\text{RAd}(\partial^{-\mu}) \circ \text{R}P)u_2 = 0$  as  $W(x)$ -modules (cf. §2.4 and §5).

**Example 7.5** (exceptional parameters). The Fuchsian differential equation with the Riemann scheme

$$\left\{ \begin{array}{cccc} x = \infty & 0 & 1 & c \\ [\delta]_{(2)} & [0]_{(2)} & [0]_{(2)} & [0]_{(2)} \\ 2 - \alpha - \beta - \gamma - 2\delta & \alpha & \beta & \gamma \end{array} \right\}$$

is a Jordan-Pochhammer equation (cf. Example 2.8 ii)) if  $\delta \neq 0$ , which is proved by the reduction using the operation  $\text{RAd}(\partial^{1-\delta}) \text{R}$  given in Theorem 7.2 ii).

The Riemann scheme of the operator

$$\begin{aligned} P_r &= x(x-1)(x-c)\partial^3 \\ &\quad - ((\alpha + \beta + \gamma - 6)x^2 - ((\alpha + \beta - 4)c + \alpha + \gamma - 4)x + (\alpha - 2)c)\partial^2 \\ &\quad - (2(\alpha + \beta + \gamma - 3)x + (\alpha + \beta - 2)c + \alpha + \gamma - 2 + r)\partial \end{aligned}$$

equals

$$\left\{ \begin{array}{cccc} x = \infty & 0 & 1 & c \\ [0]_{(2)} & [0]_{(2)} & [0]_{(2)} & [0]_{(2)} \\ 2 - \alpha - \beta - \gamma & \alpha & \beta & \gamma \end{array} \right\},$$

which corresponds to a Jordan-Pochhammer operator when  $r = 0$ . If the parameters are generic,  $\text{RAd}(\partial)P_r$  is Heun's operator (8.19) with the Riemann scheme

$$\left\{ \begin{array}{cccc} x = \infty & 0 & 1 & c \\ 2 & 0 & 0 & 0 \\ 3 - \alpha - \beta - \gamma & \alpha - 1 & \beta - 1 & \gamma - 1 \end{array} \right\},$$

which contains the accessory parameter  $r$ . This transformation doesn't satisfy (7.6) for  $\nu = 1$ .

The operator  $\text{RAd}(\partial^{1-\alpha-\beta-\gamma})P_r$  has the Riemann scheme

$$\left\{ \begin{array}{cccc} x = \infty & 0 & 1 & c \\ \alpha + \beta + \gamma - 1 & 0 & 0 & 0 \\ \alpha + \beta + \gamma & 1 - \beta - \gamma & 1 - \gamma - \alpha & 1 - \alpha - \beta \end{array} \right\}$$

and the monodromy generator at  $\infty$  is semisimple if and only if  $r = 0$ . This transformation doesn't satisfy (7.6) for  $\nu = 2$ .

**Definition 7.6.** Let

$$P = a_n(x)\partial^n + a_{n-1}(x)\partial^{n-1} + \dots + a_0(x)$$

be a Fuchsian differential operator with the Riemann scheme (6.15). Here some  $m_{j,\nu}$  may be 0. Fix  $\ell = (\ell_0, \dots, \ell_p) \in \mathbb{Z}_{>0}^{p+1}$  with  $1 \leq \ell_j \leq n_j$ . Suppose

$$(7.23) \quad \#\{j; m_{j,\ell_j} \neq n \text{ and } 0 \leq j \leq p\} \geq 2.$$

Put

$$(7.24) \quad d_\ell(\mathbf{m}) := m_{0,\ell_0} + \dots + m_{p,\ell_p} - (p-1) \text{ord } \mathbf{m}$$

and

$$(7.25)$$

$$\begin{aligned} \partial_\ell P &:= \text{Ad} \left( \prod_{j=1}^p (x-c_j)^{\lambda_{j,\ell_j}} \right) \prod_{j=1}^p (x-c_j)^{m_{j,\ell_j} - d_\ell(\mathbf{m})} \partial^{-m_{0,\ell_0}} \text{Ad}(\partial^{1-\lambda_{0,\ell_0} - \dots - \lambda_{p,\ell_p}}) \\ &\quad \cdot \partial^{(p-1)n - m_{1,\ell_1} - \dots - m_{p,\ell_p}} a_n^{-1}(x) \prod_{j=1}^n (x-c_j)^{n-m_{j,\ell_j}} \text{Ad} \left( \prod_{j=1}^p (x-c_j)^{-\lambda_{j,\ell_j}} \right) P. \end{aligned}$$

If  $\lambda_{j,\nu}$  are generic under the Fuchs relation or  $P$  is irreducible,  $\partial_\ell P$  is well-defined as an element of  $W[x]$  and

$$(7.26) \quad \partial_\ell^2 P = P \quad \text{with } P \text{ of the form (6.43),}$$

$$(7.27) \quad \begin{aligned} \partial_\ell P \in W(x) \text{RAd}\left(\prod_{j=1}^p (x - c_j)^{\lambda_{j,\ell_j}}\right) \text{RAd}(\partial^{1-\lambda_{0,\ell_0} - \dots - \lambda_{p,\ell_p}}) \\ \cdot \text{RAd}\left(\prod_{j=1}^p (x - c_j)^{-\lambda_{j,\ell_j}}\right) P \end{aligned}$$

and  $\partial_\ell$  gives a correspondence between differential operators of normal form (6.43). Here the spectral type  $\partial_\ell \mathbf{m}$  of  $\partial_\ell P$  is given by

$$(7.28) \quad \partial_\ell \mathbf{m} := (m'_{j,\nu})_{\substack{0 \leq j \leq p \\ 1 \leq \nu \leq n_j}} \quad \text{and} \quad m'_{j,\nu} = m_{j,\nu} - \delta_{\ell_j,\nu} \cdot d_\ell(\mathbf{m})$$

and the Riemann scheme of  $\partial_\ell P$  equals

$$(7.29) \quad \partial_\ell \{\lambda_{\mathbf{m}}\} := \{\lambda'_{\mathbf{m}'}\} \quad \text{with} \quad \lambda'_{j,\nu} = \begin{cases} \lambda_{0,\nu} - 2\mu_\ell & (j = 0, \nu = \ell_0) \\ \lambda_{0,\nu} - \mu_\ell & (j = 0, \nu \neq \ell_0) \\ \lambda_{j,\nu} & (1 \leq j \leq p, \nu = \ell_j) \\ \lambda_{0,\nu} + \mu_\ell & (1 \leq j \leq p, \nu \neq \ell_j) \end{cases}$$

by putting

$$(7.30) \quad \mu_\ell := \sum_{j=0}^p \lambda_{j,\ell_j} - 1.$$

It follows from Theorem 7.2 that the above assumption is satisfied if

$$(7.31) \quad m_{j,\ell_j} \geq d_\ell(\mathbf{m}) \quad (j = 0, \dots, p)$$

and

$$(7.32) \quad \sum_{j=0}^p \lambda_{j,\ell_j + (\nu - \ell_j)\delta_{j,k}} \notin \{i \in \mathbb{Z}; (p-1)n - \sum_{j=0}^p m_{j,\ell_j + (\nu - \ell_j)\delta_{j,k}} + 2 \leq i \leq 0\}$$

for  $k = 0, \dots, p$  and  $\nu = 1, \dots, n_k$ .

Note that  $\partial_\ell \mathbf{m} \in \mathcal{P}_{p+1}$  is well-defined for a given  $\mathbf{m} \in \mathcal{P}_{p+1}$  if (7.31) is valid. Moreover we define

$$(7.33) \quad \partial \mathbf{m} := \partial_{(1,1,\dots)} \mathbf{m},$$

$$(7.34) \quad \begin{aligned} \partial_{max} \mathbf{m} &:= \partial_{\ell_{max}(\mathbf{m})} \mathbf{m} \quad \text{with} \\ \ell_{max}(\mathbf{m})_j &:= \min\{\nu; m_{j,\nu} = \max\{m_{j,1}, m_{j,2}, \dots\}\}, \end{aligned}$$

$$(7.35) \quad d_{max}(\mathbf{m}) := \sum_{j=0}^p \max\{m_{j,1}, m_{j,2}, \dots, m_{j,n_j}\} - (p-1) \text{ord } \mathbf{m}.$$

For a Fuchsian differential operator  $P$  with the Riemann scheme (6.15) we define

$$(7.36) \quad \partial_{max} P := \partial_{\ell_{max}(\mathbf{m})} P \quad \text{and} \quad \partial_{max} \{\lambda_{\mathbf{m}}\} = \partial_{\ell_{max}(\mathbf{m})} \{\lambda_{\mathbf{m}}\}.$$

A tuple  $\mathbf{m} \in \mathcal{P}$  is called *basic* if  $\mathbf{m}$  is indivisible and  $d_{max}(\mathbf{m}) \leq 0$ .

**Proposition 7.7** (linear fractional transformation). *Let  $\phi$  be a linear fractional transformation of  $\mathbb{P}^1(\mathbb{C})$ , namely there exists  $\begin{pmatrix} \alpha & \beta \\ \gamma & \delta \end{pmatrix} \in GL(2, \mathbb{C})$  such that  $\phi(x) = \frac{\alpha x + \beta}{\gamma x + \delta}$ . Let  $P$  be a Fuchsian differential operator with the Riemann scheme (6.15). We may assume  $-\frac{\delta}{\gamma} = c_j$  with a suitable  $j$  by putting  $c_{p+1} = -\frac{\delta}{\gamma}$ ,  $\lambda_{p+1,1} = 0$  and*



$m_{p+1,1} = n$  if necessary. Fix  $\ell = (\ell_0, \dots, \ell_p) \in \mathbb{Z}_{>0}^{p+1}$ . If (7.31) and (7.32) are valid, we have

$$(7.37) \quad \begin{aligned} \partial_\ell P &\in W(x) \operatorname{Ad}((\gamma x + \delta)^{2\mu}) T_{\phi^{-1}}^* \partial_\ell T_\phi^* P, \\ \mu &= \lambda_{0,\ell_0} + \dots + \lambda_{p,\ell_p} - 1. \end{aligned}$$

*Proof.* The claim is clear if  $\gamma = 0$ . Hence we may assume  $\phi(x) = \frac{1}{x}$  and the claim follows from (7.11).  $\square$

*Remark 7.8.* i) Fix  $\lambda_{j,\nu} \in \mathbb{C}$ . If  $P$  has the Riemann scheme  $\{\lambda_{\mathbf{m}}\}$  with  $d_{\max}(\mathbf{m}) = 1$ ,  $\partial_\ell P$  is well-defined and  $\partial_{\max} P$  has the Riemann scheme  $\partial_{\max}\{\lambda_{\mathbf{m}}\}$ . This follows from the fact that the conditions (7.5), (7.6) and (7.7) are valid when we apply Theorem 7.2 to the operation  $\partial_{\max} : P \mapsto \partial_{\max} P$ .

ii) We remark that

$$(7.38) \quad \operatorname{idx} \mathbf{m} = \operatorname{idx} \partial_\ell \mathbf{m},$$

$$(7.39) \quad \operatorname{ord} \partial_{\max} \mathbf{m} = \operatorname{ord} \mathbf{m} - d_{\max}(\mathbf{m}).$$

Moreover if  $\operatorname{idx} \mathbf{m} > 0$ , we have

$$(7.40) \quad d_{\max}(\mathbf{m}) > 0$$

because of the identity

$$(7.41) \quad \left( \sum_{j=0}^k m_{j,\ell_j} - (p-1) \operatorname{ord} \mathbf{m} \right) \cdot \operatorname{ord} \mathbf{m} = \operatorname{idx} \mathbf{m} + \sum_{j=0}^p \sum_{\nu=1}^{n_j} (m_{j,\ell_j} - m_{j,\nu}) \cdot m_{j,\nu}.$$

If  $\operatorname{idx} \mathbf{m} = 0$ , then  $d_{\max}(\mathbf{m}) \geq 0$  and the condition  $d_{\max}(\mathbf{m}) = 0$  implies  $m_{j,\nu} = m_{j,1}$  for  $\nu = 2, \dots, n_j$  and  $j = 0, 1, \dots, p$  (cf. Corollary 8.3).

iii) The set of indices  $\ell_{\max}(\mathbf{m})$  is defined in (7.34) so that it is uniquely determined. It is sufficient to impose only the condition

$$(7.42) \quad m_{j,\ell_{\max}(\mathbf{m})_j} = \max\{m_{j,1}, m_{j,2}, \dots\} \quad (j = 0, \dots, p)$$

on  $\ell_{\max}(\mathbf{m})$  for the arguments in this paper.

Thus we have the following result.

**Theorem 7.9.** *A tuple  $\mathbf{m} \in \mathcal{P}$  is realizable if and only if  $s\mathbf{m}$  is trivial (cf. Definitions 6.10 and 6.11) or  $\partial_{\max} \mathbf{m}$  is well-defined and realizable.*

*Proof.* We may assume  $\mathbf{m} \in \mathcal{P}_{p+1}^{(n)}$  is monotone.

Suppose  $\#\{j; m_{j,1} < n\} < 2$ . Then  $\partial_{\max} \mathbf{m}$  is not well-defined. We may assume  $p = 0$  and the corresponding equation  $Pu = 0$  has no singularities in  $\mathbb{C}$  by applying a suitable addition to the equation and then  $P \in W(x)\partial^n$ . Hence  $\mathbf{m}$  is realizable if and only if  $\#\{j; m_{j,1} < n\} = 0$ , namely,  $\mathbf{m}$  is trivial.

Suppose  $\#\{j; m_{j,1} < n\} \geq 2$ . Then Theorem 7.2 assures that  $\partial_{\max} \mathbf{m}$  is realizable if and only if  $\partial_{\max} \mathbf{m}$  is realizable.  $\square$

In the next section we will prove that  $\mathbf{m}$  is realizable if  $d_{\max}(\mathbf{m}) \leq 0$ . Thus we will have a criterion whether a given  $\mathbf{m} \in \mathcal{P}$  is realizable or not by successive applications of  $\partial_{\max}$ .

**Example 7.10.** There are examples of successive applications of  $s \circ \partial$  to monotone elements of  $\mathcal{P}$ :

$$\begin{aligned} &\underline{411}, \underline{411}, \underline{42}, \underline{33} \xrightarrow{15-2-6=3} \underline{111}, \underline{111}, \underline{21} \xrightarrow{4-3=1} \underline{11}, \underline{11}, \underline{11} \xrightarrow{3-2=1} 1, 1, 1 \text{ (rigid)} \\ &\underline{211}, \underline{211}, \underline{1111} \xrightarrow{5-4=1} \underline{111}, \underline{111}, \underline{111} \xrightarrow{3-3=0} \underline{111}, \underline{111}, \underline{111} \text{ (realizable, not rigid)} \\ &\underline{211}, \underline{211}, \underline{211}, \underline{31} \xrightarrow{9-8=1} \underline{111}, \underline{111}, \underline{111}, \underline{21} \xrightarrow{5-6=-1} \text{ (realizable, not rigid)} \end{aligned}$$

$\underline{22}, \underline{22}, \underline{1111} \xrightarrow{5-4=1} \underline{21}, \underline{21}, \underline{111} \xrightarrow{5-3=2} \times$  (not realizable)

The numbers on the above arrows are  $d_{(1,1,\dots)}(\mathbf{m})$ . We sometimes delete the trivial partition as above.

The transformation of the generalized Riemann scheme of the application of  $\partial_{max}^k$  is described in the following definition.

**Definition 7.11** (Reduction of Riemann schemes). Let  $\mathbf{m} = (m_{j,\nu})_{\substack{j=0,\dots,p \\ \nu=1,\dots,n_j}} \in \mathcal{P}_{p+1}$  and  $\lambda_{j,\nu} \in \mathbb{C}$  for  $j = 0, \dots, p$  and  $\nu = 1, \dots, n_j$ . Suppose  $\mathbf{m}$  is realizable. Then there exists a positive integer  $K$  such that

$$(7.43) \quad \begin{aligned} \text{ord } \mathbf{m} &> \text{ord } \partial_{max} \mathbf{m} > \text{ord } \partial_{max}^2 \mathbf{m} > \dots > \text{ord } \partial_{max}^K \mathbf{m} \\ &\text{and } s\partial_{max}^K \mathbf{m} \text{ is trivial or } d_{max}(\partial_{max}^K \mathbf{m}) \leq 0. \end{aligned}$$

Define  $\mathbf{m}(k) \in \mathcal{P}_{p+1}$ ,  $\ell(k) \in \mathbb{Z}$ ,  $\mu(k) \in \mathbb{C}$  and  $\lambda(k)_{j,\nu \in \mathbb{C}}$  for  $k = 0, \dots, K$  by

$$(7.44) \quad \mathbf{m}(0) = \mathbf{m} \text{ and } \mathbf{m}(k) = \partial_{max} \mathbf{m}(k-1) \quad (k = 1, \dots, K),$$

$$(7.45) \quad \ell(k) = \ell_{max}(\mathbf{m}(k)) \text{ and } d(k) = d_{max}(\mathbf{m}(k)),$$

$$(7.46) \quad \{\lambda(k)_{\mathbf{m}(k)}\} = \partial_{max}^k \{\lambda_{\mathbf{m}}\} \text{ and } \mu(k) = \lambda(k+1)_{1,\nu} - \lambda(k)_{1,\nu} \quad (\nu \neq \ell(k)_1).$$

Namely we have

$$(7.47) \quad \lambda(0)_{j,\nu} = \lambda_{j,\nu} \quad (j = 0, \dots, p, \nu = 1, \dots, n_j),$$

$$(7.48) \quad \mu(k) = \sum_{j=0}^p \lambda(k)_{j,\ell(k)_j} - 1,$$

$$(7.49) \quad \lambda(k+1)_{j,\nu} = \begin{cases} \lambda(k)_{0,\nu} - 2\mu(k) & (j = 0, \nu = \ell(k)_0), \\ \lambda(k)_{0,\nu} - \mu(k) & (j = 0, 1 \leq \nu \leq n_0, \nu \neq \ell(k)_0), \\ \lambda(k)_{j,\nu} & (1 \leq j \leq p, \nu = \ell(k)_j), \\ \lambda(k)_{j,\nu} + \mu(k) & (1 \leq j \leq p, 1 \leq \nu \leq n_j, \nu \neq \ell(k)_j) \end{cases}$$

$$= \lambda(k)_{j,\nu} + ((-1)^{\delta_{j,0}} - \delta_{\nu,\ell(k)_j})\mu(k),$$

$$(7.50) \quad \{\lambda_{\mathbf{m}}\} \xrightarrow{\partial_{\ell(0)}} \dots \longrightarrow \{\lambda(k)_{\mathbf{m}(k)}\} \xrightarrow{\partial_{\ell(k)}} \{\lambda(k+1)_{\mathbf{m}(k+1)}\} \xrightarrow{\partial_{\ell(k+1)}} \dots$$

## 8. DELIGNE-SIMPSON PROBLEM

In this section we give an answer for the existence and the construction of Fuchsian differential equations with given Riemann schemes and examine the irreducibility for generic spectral parameters.

**8.1. Fundamental lemmas.** First we prepare two lemmas to construct Fuchsian differential operators with a given spectral type.

**Definition 8.1.** For  $\mathbf{m} = (m_{j,\nu})_{\substack{j=0,\dots,p \\ 1 \leq \nu \leq n_j}} \in \mathcal{P}_{p+1}^{(n)}$ , we put

$$(8.1) \quad \begin{aligned} N_{\nu}(\mathbf{m}) &:= (p-1)(\nu+1) + 1 \\ &\quad - \#\{(j,i) \in \mathbb{Z}^2; i \geq 0, 0 \leq j \leq p, \tilde{m}_{j,i} \geq n - \nu\}, \end{aligned}$$

$$(8.2) \quad \tilde{m}_{j,i} := \sum_{\nu=1}^{n_j} \max\{m_{j,\nu} - i, 0\}.$$

See the Young diagram in (8.32) and its explanation for an interpretation of the number  $\tilde{m}_{j,i}$ .

**Lemma 8.2.** *We assume that  $\mathbf{m} = (m_{j,\nu})_{\substack{j=0,\dots,p \\ 1 \leq \nu \leq n_j}} \in \mathcal{P}_{p+1}^{(n)}$  satisfies*

$$(8.3) \quad m_{j,1} \geq m_{j,2} \geq \dots \geq m_{j,n_j} > 0 \quad \text{and} \quad n > m_{0,1} \geq m_{1,1} \geq \dots \geq m_{p,1}$$

and

$$(8.4) \quad m_{0,1} + \dots + m_{p,1} \leq (p-1)n.$$

Then

$$(8.5) \quad N_\nu(\mathbf{m}) \geq 0 \quad (\nu = 2, 3, \dots, n-1)$$

if and only if  $\mathbf{m}$  is not any one of

$$(8.6) \quad \begin{aligned} & (k, k; k, k; k, k; k, k), \quad (k, k, k; k, k, k; k, k, k), \\ & (2k, 2k; k, k, k, k; k, k, k, k) \\ & \text{and } (3k, 3k; 2k, 2k, 2k; k, k, k, k, k, k) \text{ with } k \geq 2. \end{aligned}$$

*Proof.* Put

$$\phi_j(t) := \sum_{\nu=1}^{n_j} \max\{m_{j,\nu} - t, 0\} \quad \text{and} \quad \bar{\phi}_j(t) := n \left(1 - \frac{t}{m_{j,1}}\right) \quad \text{for } j = 0, \dots, p.$$

Then  $\phi_j(t)$  and  $\bar{\phi}_j(t)$  are strictly decreasing continuous functions of  $t \in [0, m_{j,1}]$  and

$$\begin{aligned} \phi_j(0) &= \bar{\phi}_j(0) = n, \\ \phi_j(m_{j,1}) &= \bar{\phi}_j(m_{j,1}) = 0, \\ 2\phi_j\left(\frac{t_1+t_2}{2}\right) &\leq \phi_j(t_1) + \phi_j(t_2) & (0 \leq t_1 \leq t_2 \leq m_{j,1}), \\ \phi'_j(t) &= -n_j \leq -\frac{n}{m_{j,1}} = \bar{\phi}'_j(t) & (0 < t < 1). \end{aligned}$$

Hence we have

$$\begin{aligned} \phi_j(t) &= \bar{\phi}_j(t) & (0 < t < m_{j,1}, \quad n = m_{j,1}n_j), \\ \phi_j(t) &< \bar{\phi}_j(t) & (0 < t < m_{j,1}, \quad n < m_{j,1}n_j) \end{aligned}$$

and for  $\nu = 2, \dots, n-1$

$$\begin{aligned} \sum_{j=0}^p \#\{i \in \mathbb{Z}_{\geq 0}; \phi_j(i) \geq n - \nu\} &= \sum_{j=0}^p [\phi_j^{-1}(n - \nu) + 1] \\ &\leq \sum_{j=0}^p (\bar{\phi}_j^{-1}(n - \nu) + 1) \\ &\leq \sum_{j=0}^p (\bar{\phi}_j^{-1}(n - \nu) + 1) = \sum_{j=0}^p \left(\frac{\nu m_{j,1}}{n} + 1\right) \\ &\leq (p-1)\nu + (p+1) = (p-1)(\nu+1) + 2. \end{aligned}$$

Here  $[r]$  means the largest integer which is not larger than a real number  $r$ .

Suppose there exists  $\nu$  with  $2 \leq \nu \leq n-1$  such that (8.5) doesn't hold. Then the equality holds in the above each line, which means

$$(8.7) \quad \begin{aligned} \phi_j^{-1}(n - \nu) &\in \mathbb{Z} & (j = 0, \dots, p), \\ n &= m_{j,1}n_j & (j = 0, \dots, p), \\ (p-1)n &= m_{0,1} + \dots + m_{p,1}. \end{aligned}$$

Note that  $n = m_{j,1}n_j$  implies  $m_{j,1} = \dots = m_{j,n_j} = \frac{n}{n_j}$  and  $p-1 = \frac{1}{n_0} + \dots + \frac{1}{n_p} \leq \frac{p+1}{2}$ . Hence  $p = 3$  with  $n_0 = n_1 = n_2 = n_3 = 2$  or  $p = 2$  with  $1 = \frac{1}{n_0} + \frac{1}{n_1} + \frac{1}{n_2}$ . If

$p = 2$ ,  $\{n_0, n_1, n_2\}$  equals  $\{3, 3, 3\}$  or  $\{2, 4, 4\}$  or  $\{2, 3, 6\}$ . Thus we have (8.6) with  $k = 1, 2, \dots$ . Moreover since

$$\phi_j^{-1}(n - \nu) = \bar{\phi}_j^{-1}(n - \nu) = \frac{\nu m_{j,1}}{n} = \frac{\nu}{n_j} \in \mathbb{Z} \quad (j = 0, \dots, p),$$

$\nu$  is a common multiple of  $n_0, \dots, n_p$  and thus  $k \geq 2$ . If  $\nu$  is the least common multiple of  $n_0, \dots, n_p$  and  $k \geq 2$ , then (8.7) is valid and the equality holds in the above each line and hence (8.5) is not valid.  $\square$

**Corollary 8.3** (Kostov [Ko3]). *Let  $\mathbf{m} \in \mathcal{P}$  satisfying  $\text{idx } \mathbf{m} = 0$  and  $d_{\max}(\mathbf{m}) \leq 0$ . Then  $\mathbf{m}$  is isomorphic to one of the tuples in (8.6) with  $k = 1, 2, 3, \dots$*

*Proof.* Remark 7.8 assures that  $d_{\max}(\mathbf{m}) = 0$  and  $n = m_{j,1}n_j$ . Then the proof of the final part of Lemma 8.2 shows the corollary.  $\square$

**Lemma 8.4.** *Let  $c_0, \dots, c_p$  be  $p + 1$  distinct points in  $\mathbb{C} \cup \{\infty\}$ . Let  $n_0, n_1, \dots, n_p$  be non-negative integers and let  $a_{j,\nu}$  be complex numbers for  $j = 0, \dots, p$  and  $\nu = 1, \dots, n_j$ . Put  $\tilde{n} := n_0 + \dots + n_p$ . Then there exists a unique polynomial  $f(x)$  of degree  $\tilde{n} - 1$  such that*

$$(8.8) \quad \begin{aligned} f(x) &= a_{j,1} + a_{j,2}(x - c_j) + \dots + a_{j,n_j}(x - c_j)^{n_j-1} \\ &\quad + o(|x - c_j|^{n_j-1}) \quad (x \rightarrow c_j, c_j \neq \infty), \\ x^{1-\tilde{n}}f(x) &= a_{j,1} + a_{j,2}x^{-1} + a_{j,n_j}x^{1-n_j} + o(|x|^{1-n_j}) \\ &\quad (x \rightarrow \infty, c_j = \infty). \end{aligned}$$

Moreover the coefficients of  $f(x)$  are linear functions of the  $\tilde{n}$  variables  $a_{j,\nu}$ .

*Proof.* We may assume  $c_p = \infty$  with allowing  $n_p = 0$ . Put  $\tilde{n}_i = n_0 + \dots + n_{i-1}$  and  $\tilde{n}_0 = 0$ . For  $k = 0, \dots, \tilde{n} - 1$  we define

$$f_k(x) := \begin{cases} (x - c_i)^{k-\tilde{n}_i} \prod_{\nu=0}^{i-1} (x - c_\nu)^{n_\nu} & (\tilde{n}_i \leq k < \tilde{n}_{i+1}, 0 \leq i < p), \\ x^{k-\tilde{n}_p} \prod_{\nu=0}^{p-1} (x - c_\nu)^{n_\nu} & (\tilde{n}_p \leq k < \tilde{n}). \end{cases}$$

Since  $\deg f_k(x) = k$ , the polynomials  $f_0(x), f_1(x), \dots, f_{\tilde{n}-1}(x)$  are linearly independent over  $\mathbb{C}$ . Put  $f(x) = \sum_{k=0}^{\tilde{n}-1} u_k f_k(x)$  with  $c_k \in \mathbb{C}$  and

$$v_k = \begin{cases} a_{i,k-\tilde{n}_i+1} & (\tilde{n}_i \leq k < \tilde{n}_{i+1}, 0 \leq i < p), \\ a_{p,\tilde{n}-k} & (\tilde{n}_p \leq k < \tilde{n}) \end{cases}$$

by (8.8). The correspondence which maps the column vectors  $u := (u_k)_{k=0, \dots, \tilde{n}-1} \in \mathbb{C}^{\tilde{n}}$  to the column vectors  $v := (v_k)_{k=0, \dots, \tilde{n}-1} \in \mathbb{C}^{\tilde{n}}$  is given by  $v = Au$  with a square matrix  $A$  of size  $\tilde{n}$ . Then  $A$  is an upper triangular matrix of size  $\tilde{n}$  with non-zero diagonal entries and therefore the lemma is clear.  $\square$

## 8.2. Existence theorem.

**Definition 8.5** (Top term). Let

$$P = a_n(x) \frac{d^n}{dx^n} + a_{n-1}(x) \frac{d^{n-1}}{dx^{n-1}} + \dots + a_1(x) \frac{d}{dx} + a_0(x)$$

be a differential operator with polynomial coefficients. Suppose  $a_n \neq 0$ . If  $a_n(x)$  is a polynomial of degree  $k$  with respect to  $x$ , we define  $\text{Top } P := a_{n,k} x^k \partial^n$  with the coefficient  $a_{n,k}$  of the term  $x^k$  of  $a_n(x)$ . We put  $\text{Top } P = 0$  when  $P = 0$ .

**Theorem 8.6.** *Suppose  $\mathbf{m} \in \mathcal{P}_{p+1}^{(n)}$  satisfies (8.3). Retain the notation in Definition 8.1.*

i) We have  $N_1(\mathbf{m}) = p - 2$  and

$$(8.9) \quad \sum_{\nu=1}^{n-1} N_\nu(\mathbf{m}) = \text{Pid} \mathbf{m}.$$

ii) Suppose  $p \geq 2$  and  $N_\nu(\mathbf{m}) \geq 0$  for  $\nu = 2, \dots, n-1$ . Put

$$(8.10) \quad q_\nu^0 := \#\{i; \tilde{m}_{0,i} \geq n - \nu, i \geq 0\},$$

$$(8.11) \quad I_{\mathbf{m}} := \{(j, \nu) \in \mathbb{Z}^2; q_\nu^0 \leq j < q_\nu^0 + N_\nu(\mathbf{m}) \text{ and } 1 \leq \nu \leq n-1\}.$$

Then there uniquely exists a Fuchsian differential operator  $P$  of the normal form (6.43) which has the Riemann scheme (6.15) with  $c_0 = \infty$  under the Fuchs relation (6.16) and satisfies

$$(8.12) \quad \frac{1}{(\deg P - j - \nu)!} \frac{d^{\deg P - j - \nu} a_{n-\nu-1}}{dx^{\deg P - j - \nu}}(0) = g_{j,\nu} \quad (\forall (j, \nu) \in I_{\mathbf{m}}).$$

Here  $(g_{j,\nu})_{(j,\nu) \in I_{\mathbf{m}}} \in \mathbb{C}^{\text{Pid} \mathbf{m}}$  is arbitrarily given. Moreover the coefficients of  $P$  are polynomials of  $x$ ,  $\lambda_{j,\nu}$  and  $g_{j,\nu}$  and satisfy

$$(8.13) \quad x^{j+\nu} \text{Top} \left( \frac{\partial P}{\partial g_{j,\nu}} \right) \partial^{\nu+1} = \text{Top} P \quad \text{and} \quad \frac{\partial^2 P}{\partial g_{j,\nu}^2} = 0.$$

Fix the characteristic exponents  $\lambda_{j,\nu} \in \mathbb{C}$  satisfying the Fuchs relation. Then all the Fuchsian differential operators of the normal form with the Riemann scheme (6.15) are parametrized by  $(g_{j,\nu}) \in \mathbb{C}^{\text{Pid} \mathbf{m}}$ . Hence the operators are unique if and only if  $\text{Pid} \mathbf{m} = 0$ .

*Proof.* i) Since  $\tilde{m}_{j,1} = n - n_j \leq n - 2$ ,  $N_1(\mathbf{m}) = 2(p-1) + 1 - (p+1) = p-2$  and

$$\begin{aligned} & \sum_{\nu=1}^{n-1} \#\{(j, i) \in \mathbb{Z}^2; i \geq 0, 0 \leq j \leq p, \tilde{m}_{j,i} \geq n - \nu\} \\ &= \sum_{j=0}^p \left( \sum_{\nu=0}^{n-1} \#\{i \in \mathbb{Z}_{\geq 0}; \tilde{m}_{j,i} \geq n - \nu\} - 1 \right) \\ &= \sum_{j=0}^p \left( \sum_{i=0}^{m_{j,1}} \tilde{m}_{j,i} - 1 \right) = \sum_{j=0}^p \left( \sum_{i=0}^{m_{j,1}} \sum_{\nu=1}^{n_j} \max\{m_{j,\nu} - i, 0\} - 1 \right) \\ &= \sum_{j=0}^p \left( \sum_{\nu=1}^{n_j} \frac{m_{j,\nu}(m_{j,\nu} + 1)}{2} - 1 \right) \\ &= \frac{1}{2} \left( \sum_{j=0}^p \sum_{\nu=1}^{n_j} m_{j,\nu}^2 + (p+1)(n-2) \right), \\ \sum_{\nu=1}^{n-1} N_\nu(\mathbf{m}) &= (p-1) \left( \frac{n(n+1)}{2} - 1 \right) + (n-1) - \frac{1}{2} \left( \sum_{j=0}^p \sum_{\nu=1}^{n_j} m_{j,\nu}^2 + (p+1)(n-2) \right) \\ &= \frac{1}{2} \left( (p-1)n^2 + 2 - \sum_{j=0}^p \sum_{\nu=1}^{n_j} m_{j,\nu}^2 \right) = \text{Pid} \mathbf{m}. \end{aligned}$$

ii) Put

$$\begin{aligned} P &= \sum_{\ell=0}^{pn} x^{pn-\ell} p_{0,\ell}^P(\vartheta) \\ &= \sum_{\ell=0}^{pn} (x - c_j)^\ell p_{j,\ell}^P((x - c_j)\partial) \quad (1 \leq j \leq n), \\ h_{j,\ell}(t) &:= \begin{cases} \prod_{\nu=1}^{n_0} \prod_{0 \leq i < m_{0,\nu} - \ell} (t + \lambda_{0,\nu} + i) & (j = 0), \\ \prod_{\nu=1}^{n_j} \prod_{0 \leq i < m_{j,\nu} - \ell} (t - \lambda_{j,\nu} - i) & (1 \leq j \leq p), \end{cases} \\ p_{j,\ell}^P(t) &= q_{j,\ell}^P(t) h_{j,\ell}(t) + r_{j,\ell}^P(t) \quad (\deg r_{j,\ell}^P(t) < \deg h_{j,\ell}(t)). \end{aligned}$$

Here  $p_{j,\ell}^P(t)$ ,  $q_{j,\ell}^P(t)$ ,  $r_{j,\ell}^P(t)$  and  $h_{j,\ell}(t)$  are polynomials of  $t$  and

$$(8.14) \quad \deg h_{j,\ell} = \sum_{\nu=1}^{n_j} \max\{m_{j,\nu} - \ell, 0\}.$$

The condition that  $P$  of the form (6.43) have the Riemann scheme (6.15) if and only if  $r_{j,\ell}^P = 0$  for any  $j$  and  $\ell$ . Note that  $a_{n-k}(x) \in \mathbb{C}[x]$  should satisfy

$$(8.15) \quad \deg a_{n-k}(x) \leq pn - k \quad \text{and} \quad a_{n-k}^{(\nu)}(c_j) = 0 \quad (0 \leq \nu \leq n - k - 1, 1 \leq k \leq n),$$

which is equivalent to the condition that  $P$  is of the Fuchsian type.

Put  $P(k) := \left(\prod_{j=1}^p (x - c_j)^n\right) \frac{d^n}{dx^n} + a_{n-1}(x) \frac{d^{n-1}}{dx^{n-1}} + \cdots + a_{n-k}(x) \frac{d^{n-k}}{dx^{n-k}}$ .

Assume that  $a_{n-1}(x), \dots, a_{n-k+1}(x)$  have already defined so that  $\deg r_{j,\ell}^{P(k-1)} < n - k + 1$  and we will define  $a_{n-k}(x)$  so that  $\deg r_{j,\ell}^{P(k)} < n - k$ .

When  $k = 1$ , we put

$$a_{n-1}(x) = -a_n(x) \sum_{j=1}^p (x - c_j)^{-1} \sum_{\nu=1}^{n_j} \sum_{i=0}^{m_{j,\nu}-1} (\lambda_{j,\nu} + i)$$

and then we have  $\deg r_{j,\ell}^{P(1)} < n - 1$  for  $j = 1, \dots, p$ . Moreover we have  $\deg r_{0,\ell}^{P(1)} < n - 1$  because of the Fuchs relation.

Suppose  $k \geq 2$  and put

$$a_{n-k}(x) = \begin{cases} \sum_{\ell \geq 0} c_{0,k,\ell} x^{pn-k-\ell}, \\ \sum_{\ell \geq 0} c_{j,k,\ell} (x - c_j)^{n-k+\ell} \quad (j = 1, \dots, p) \end{cases}$$

with  $c_{i,j,\ell} \in \mathbb{C}$ . Note that

$$\begin{aligned} a_{n-k}(x) \partial^{n-k} &= \sum_{\ell \geq 0} c_{0,k,\ell} x^{(p-1)n-\ell} \prod_{i=0}^{n-k-1} (\vartheta - i) \\ &= \sum_{\ell \geq 0} c_{j,k,\ell} (x - c_j)^\ell \prod_{i=0}^{n-k-1} ((x - c_j)\partial - i). \end{aligned}$$

Then  $\deg r_{j,\ell}^{P(k)} < n - k$  if and only if  $\deg h_{j,\ell} \leq n - k$  or

$$(8.16) \quad c_{j,k,\ell} = -\frac{1}{(n-k)!} \left( \frac{d^{n-k}}{dt^{n-k}} r_{j,\ell}^{P(k-1)}(t) \right) \Big|_{t=0}.$$

Namely we impose the condition (8.16) for all  $(j, \ell)$  satisfying

$$\tilde{m}_{j,\ell} = \sum_{\nu=1}^{n_j} \max\{m_{j,\nu} - \ell, 0\} > n - k.$$

The number of the pairs  $(j, \ell)$  satisfying this condition equals  $(p-1)k+1-N_{k-1}(\mathbf{m})$ . Together with the conditions  $a_{n-k}^{(\nu)}(c_j) = 0$  for  $j = 1, \dots, p$  and  $\nu = 0, \dots, n-k-1$ , the total number of conditions imposing to the polynomial  $a_{n-k}(x)$  of degree  $pn-k$  equals

$$p(n-k) + (p-1)k + 1 - N_{k-1}(\mathbf{m}) = (pn-k+1) - N_{k-1}(\mathbf{m}).$$

Hence Lemma 8.4 shows that  $a_{n-k}(x)$  is uniquely defined by giving  $c_{0,k,\ell}$  arbitrarily for  $q_{k-1}^0 \leq \ell < q_{k-1}^0 + N_{k-1}(\mathbf{m})$  because  $q_{k-1}^0 = \#\{\ell \geq 0; \tilde{m}_{0,\ell} > n-k\}$ . Thus we have the theorem.  $\square$

*Remark 8.7.* The numbers  $N_\nu(\mathbf{m})$  don't change if we replace a  $(p+1)$ -tuple  $\mathbf{m}$  of partitions of  $n$  by the  $(p+2)$ -tuple of partitions of  $n$  defined by adding a trivial partition  $n = n$  of  $n$  to  $\mathbf{m}$ .

**Example 8.8.** We will examine the number  $N_\nu(\mathbf{m})$  in Theorem 8.6. In the case of the Simpson's list (cf. §15.2) we have the following.

( $H_n$ : hypergeometric family)

$$\begin{aligned} \mathbf{m} &= n-11, 1^n, 1^n \\ \tilde{\mathbf{m}} &= n, n-2, n-3, \dots, 1; n; n \end{aligned}$$

( $EO_{2m}$ : even family)

$$\begin{aligned} \mathbf{m} &= mm, mm-11, 1^{2m} \\ \tilde{\mathbf{m}} &= 2m, 2m-2, \dots, 2; 2m, 2m-3, \dots, 1; 2m \end{aligned}$$

( $EO_{2m+1}$ : odd family)

$$\begin{aligned} \mathbf{m} &= m+1m, mm1, 1^{2m+1} \\ \tilde{\mathbf{m}} &= 2m+1, 2m-1, \dots, 1; 2m+1, 2m-2, \dots, 2; 2m+1 \end{aligned}$$

( $X_6$ : extra case)

$$\begin{aligned} \mathbf{m} &= 42, 222, 1^6 \\ \tilde{\mathbf{m}} &= 6, 4, 2, 1; 6, 3; 6 \end{aligned}$$

In these cases  $p = 2$  and we have  $N_\nu(\mathbf{m}) = 0$  for  $\nu = 1, 2, \dots, n-1$  because

$$\begin{aligned} (8.17) \quad \tilde{\mathbf{m}} &:= \{\tilde{m}_{j,\nu}; \nu = 0, \dots, m_{j,1}-1, j = 0, \dots, p\} \\ &= \{n, n, n, n-2, n-3, n-4, \dots, 2, 1\}. \end{aligned}$$

See Proposition 8.16 ii) for the condition that  $N_\nu(\mathbf{m}) \geq 0$  for  $\nu = 1, \dots, \text{ord } \mathbf{m} - 1$ .

We give other examples:

$\mathbf{m}$	Pidx	$\tilde{\mathbf{m}}$	$N_1, N_2, \dots, N_{\text{ord } \mathbf{m}-1}$
221, 221, 221	0	52, 52, 52	0, 1, -1, 0
21, 21, 21, 21 ( $P_3$ )	0	31, 31, 31, 31	1, -1
22, 22, 22	-3	42, 42, 42	0, -2, -1
11, 11, 11, 11 ( $\tilde{D}_4$ )	1	2, 2, 2, 2	1
111, 111, 111 ( $\tilde{E}_6$ )	1	3, 3, 3	0, 1
22, 1111, 1111 ( $\tilde{E}_7$ )	1	42, 4, 4	0, 0, 1
33, 222, 111111 ( $\tilde{E}_8$ )	1	642, 63, 6	0, 0, 0, 0, 1
21, 21, 21, 111	1	31, 31, 31, 3	1, 0
222, 222, 222	1	63, 63, 63	0, 1, -1, 0, 1
11, 11, 11, 11, 11	2	2, 2, 2, 2, 2	2
55, 3331, 22222	2	10, 8, 6, 4, 2; 10, 6, 3; 10, 5	0, 0, 1, 0, 0, 0, 0, 1
22, 22, 22, 211	2	42, 42, 42, 41	1, 0, 1
22, 22, 22, 22, 22	5	42, 42, 42, 42, 42	2, 0, 3
32111, 3221, 2222	8	831, 841, 84	0, 1, 2, 1, 1, 2, 1

Note that if Pidx  $\mathbf{m} = 0$ , in particular, if  $\mathbf{m}$  is rigid, then  $\mathbf{m}$  doesn't satisfy (8.4). The tuple 222, 222, 222 of partitions is the second case in (8.6) with  $k = 2$ .

*Remark 8.9.* Note that [O6, Proposition 8.1] proves that there exist only finite basic tuples of partitions with a fixed index of rigidity.

Those with index of rigidity 0 are of only 4 types, which are  $\tilde{D}_4$ ,  $\tilde{E}_6$ ,  $\tilde{E}_7$  and  $\tilde{E}_8$  given in the above (cf. Corollary 8.3, Kostov [Ko3]). Namely those are in the  $S_\infty$ -orbit of

$$(8.18) \quad \{11, 11, 11, 11 \quad 111, 111, 111 \quad 22, 1111, 1111 \quad 33, 222, 111111\}$$

and the operator  $P$  in Theorem 8.6 with any one of this spectral type has one accessory parameter in its 0-th order term.

The equation corresponding to 11, 11, 11, 11 is called Heun's equation (cf. [SW, WW]), which is given by the operator

$$(8.19) \quad \begin{aligned} P_{\alpha, \beta, \gamma, \delta, \lambda} = & x(x-1)(x-c)\partial^2 + (\gamma(x-1)(x-c) + \delta x(x-c) \\ & + (\alpha + \beta + 1 - \gamma - \delta)x(x-1))\partial + \alpha\beta x - \lambda \end{aligned}$$

with the Riemann scheme

$$(8.20) \quad \left\{ \begin{array}{cccc} x=0 & 1 & c & \infty \\ 0 & 0 & 0 & \alpha \\ 1-\gamma & 1-\delta & \gamma+\delta-\alpha-\beta & \beta \end{array} ; \begin{array}{l} x \\ \lambda \end{array} \right\}.$$

Here  $\lambda$  is an accessory parameter. Our operation cannot decrease the order of  $P_{\alpha, \beta, \gamma, \delta, \lambda}$  but gives the following transformation.

$$(8.21) \quad \begin{aligned} \text{Ad}(\partial^{1-\alpha})P_{\alpha, \beta, \gamma, \delta, \lambda} &= P_{\alpha', \beta', \gamma', \delta', \lambda'}, \\ \left\{ \begin{array}{l} \alpha' = 2 - \alpha, \quad \beta' = \beta - \alpha + 1, \quad \gamma' = \gamma - \alpha + 1, \quad \delta' = \delta - \alpha + 1, \\ \lambda' = \lambda + (1 - \alpha)(\beta - \delta + 1 + (\gamma + \delta - \alpha)c). \end{array} \right. \end{aligned}$$

**Proposition 8.10.** ([O6, Proposition 8.4]). *The basic tuples of partitions with index of rigidity  $-2$  are in the  $S_\infty$ -orbit of the set of the 13 tuples*

$$\begin{aligned} & \{11, 11, 11, 11, 11 \quad 21, 21, 111, 111 \quad 31, 22, 22, 1111 \quad 22, 22, 22, 211 \\ & \quad 211, 1111, 1111 \quad 221, 221, 11111 \quad 32, 11111, 11111 \quad 222, 222, 2211 \\ & \quad 33, 2211, 111111 \quad 44, 2222, 22211 \quad 44, 332, 1111111 \quad 55, 3331, 22222 \\ & \quad 66, 444, 2222211\}. \end{aligned}$$

*Proof.* Here we give the proof in [O6].

Assume that  $\mathbf{m} \in \mathcal{P}_{p+1}$  is basic and monotone and  $\text{idx } \mathbf{m} = -2$ . Note that (7.41) shows

$$0 \leq \sum_{j=0}^p \sum_{\nu=2}^{n_j} (m_{j,1} - m_{j,\nu}) \cdot m_{j,\nu} \leq -\text{idx } \mathbf{m} = 2.$$

Hence (7.41) implies  $\sum_{j=0}^p \sum_{\nu=2}^{n_j} (m_{j,1} - m_{j,\nu})m_{j,\nu} = 0$  or 2 and we have only to examine the following 5 possibilities.

- (A)  $m_{0,1} \cdots m_{0,n_0} = 2 \cdots 211$  and  $m_{j,1} = m_{j,n_j}$  for  $1 \leq j \leq p$ .
- (B)  $m_{0,1} \cdots m_{0,n_0} = 3 \cdots 31$  and  $m_{j,1} = m_{j,n_j}$  for  $1 \leq j \leq p$ .
- (C)  $m_{0,1} \cdots m_{0,n_0} = 3 \cdots 32$  and  $m_{j,1} = m_{j,n_j}$  for  $1 \leq j \leq p$ .
- (D)  $m_{i,1} \cdots m_{i,n_0} = 2 \cdots 21$  and  $m_{j,1} = m_{j,n_j}$  for  $0 \leq i \leq 1 < j \leq p$ .
- (E)  $m_{j,1} = m_{j,n_j}$  for  $0 \leq j \leq p$  and  $\text{ord } \mathbf{m} = 2$ .

Case (A). If  $2 \cdots 211$  is replaced by  $2 \cdots 22$ ,  $\mathbf{m}$  is transformed into  $\mathbf{m}'$  with  $\text{idx } \mathbf{m}' = 0$ . If  $\mathbf{m}'$  is indivisible,  $\mathbf{m}'$  is basic and  $\text{idx } \mathbf{m}' = 0$  and therefore  $\mathbf{m}$  is  $211, 1^4, 1^4$  or  $33, 2211, 1^6$ . If  $\mathbf{m}'$  is not indivisible,  $\frac{1}{2}\mathbf{m}'$  is basic and  $\text{idx } \frac{1}{2}\mathbf{m}' = 0$  and hence  $\mathbf{m}$  is one of the tuples in

$$\{211, 22, 22, 22 \quad 2211, 222, 222 \quad 22211, 2222, 44 \quad 2222211, 444, 66\}.$$



Put  $m = n_0 - 1$  and examine the identity

$$\sum_{j=0}^p \frac{m_{j,1}}{\text{ord } \mathbf{m}} = p - 1 + (\text{ord } \mathbf{m})^{-2} \left( \text{id}_x \mathbf{m} + \sum_{j=0}^p \sum_{\nu=1}^{n_j} (m_{j,1} - m_{j,\nu}) m_{j,\nu} \right)$$

Case (B). Note that  $\text{ord } \mathbf{m} = 3m + 1$  and therefore  $\frac{3}{3m+1} + \frac{1}{n_1} + \cdots + \frac{1}{n_p} = p - 1$ . Since  $n_j \geq 2$ , we have  $\frac{1}{2}p - 1 \leq \frac{3}{3m+1} < 1$  and  $p \leq 3$ .

If  $p = 3$ , we have  $m = 1$ ,  $\text{ord } \mathbf{m} = 4$ ,  $\frac{1}{n_1} + \frac{1}{n_2} + \frac{1}{n_3} = \frac{5}{4}$ ,  $\{n_1, n_2, n_3\} = \{2, 2, 4\}$  and  $\mathbf{m} = 31, 22, 22, 1111$ .

Assume  $p = 2$ . Then  $\frac{1}{n_1} + \frac{1}{n_2} = 1 - \frac{3}{3m+1}$ . If  $\min\{n_1, n_2\} \geq 3$ ,  $\frac{1}{n_1} + \frac{1}{n_2} \leq \frac{2}{3}$  and  $m \leq 2$ . If  $\min\{n_1, n_2\} = 2$ ,  $\max\{n_1, n_2\} \geq 3$  and  $\frac{3}{3m+1} \geq \frac{1}{6}$  and  $m \leq 5$ . Note that  $\frac{1}{n_1} + \frac{1}{n_2} = \frac{13}{16}, \frac{10}{13}, \frac{7}{10}, \frac{4}{7}$  and  $\frac{1}{4}$  according to  $m = 5, 4, 3, 2$  and  $1$ , respectively. Hence we have  $m = 3$ ,  $\{n_1, n_2\} = \{2, 5\}$  and  $\mathbf{m} = 3331, 55, 22222$ .

Case (C). We have  $\frac{3}{3m+2} + \frac{1}{n_1} + \cdots + \frac{1}{n_p} = p - 1$ . Since  $n_j \geq 2$ ,  $\frac{1}{2}p - 1 \leq \frac{3}{3m+2} < 1$  and  $p \leq 3$ . If  $p = 3$ , then  $m = 1$ ,  $\text{ord } \mathbf{m} = 5$  and  $\frac{1}{n_1} + \frac{1}{n_2} + \frac{1}{n_3} = \frac{7}{5}$ , which never occurs.

Thus we have  $p = 2$ ,  $\frac{1}{n_1} + \frac{1}{n_2} = 1 - \frac{3}{3m+2}$  and hence  $m \leq 5$  as in Case (B). Then  $\frac{1}{n_1} + \frac{1}{n_2} = \frac{14}{17}, \frac{11}{14}, \frac{8}{11}, \frac{5}{8}$  and  $\frac{2}{5}$  according to  $m = 5, 4, 3, 2$  and  $1$ , respectively. Hence we have  $m = 1$  and  $n_1 = n_2 = 5$  and  $\mathbf{m} = 32, 11111, 11111$  or  $m = 2$  and  $n_1 = 2$  and  $n_2 = 8$  and  $\mathbf{m} = 332, 44, 11111111$ .

Case (D). We have  $\frac{2}{2m+1} + \frac{2}{2m+1} + \frac{1}{n_2} + \cdots + \frac{1}{n_p} = p - 1$ . Since  $n_j \geq 3$  for  $j \geq 2$ , we have  $p - 1 \leq \frac{3}{2} \frac{4}{2m+1} = \frac{6}{2m+1}$  and  $m \leq 2$ . If  $m = 1$ , then  $p = 3$  and  $\frac{1}{n_2} + \frac{1}{n_3} = 2 - \frac{4}{3} = \frac{2}{3}$  and we have  $\mathbf{m} = 21, 21, 111, 111$ . If  $m = 2$ , then  $p = 2$ ,  $\frac{1}{n_2} = 1 - \frac{4}{5}$  and  $\mathbf{m} = 221, 221, 11111$ .

Case (E). Since  $m_{j,1} = 1$  and (7.41) means  $-2 = \sum_{j=0}^p 2m_{j,1} - 4(p - 1)$ , we have  $p = 4$  and  $\mathbf{m} = 11, 11, 11, 11, 11$ .  $\square$

### 8.3. Divisible spectral types.

**Proposition 8.11.** *Let  $\mathbf{m}$  be any one of the partition of type  $\tilde{D}_4, \tilde{E}_6, \tilde{E}_7$  or  $\tilde{E}_8$  in Example 8.8 and put  $n = \text{ord } \mathbf{m}$ . Then  $k\mathbf{m}$  is realizable but it isn't irreducibly realizable for  $k = 2, 3, \dots$ . Moreover we have the operator  $P$  of order  $k \text{ord } \mathbf{m}$  satisfying the properties in Theorem 8.6 ii) for the tuple  $k\mathbf{m}$ .*

*Proof.* Let  $P(k, c)$  be the operator of the normal form with the Riemann scheme

$$\left\{ \begin{array}{cc} x = c_0 = \infty & x = c_j \ (j = 1, \dots, p) \\ [\lambda_{0,1} - k(p-1)n + km_{0,1}]_{(m_{0,1})} & [\lambda_{j,1} + km_{j,1}]_{(m_{j,1})} \\ \vdots & \vdots \\ [\lambda_{0,n_1} - k(p-1)n + km_{0,1}]_{(m_{0,n_1})} & [\lambda_{j,n_j} + km_{j,n_j}]_{(m_{j,n_j})} \end{array} \right\}$$

of type  $\mathbf{m}$ . Here  $\mathbf{m} = (m_{j,\nu})_{\substack{j=0,\dots,p \\ \nu=1,\dots,n_j}}$ ,  $n = \text{ord } \mathbf{m}$  and  $c$  is the accessory parameter contained in the coefficient of the 0-th order term of  $P(k, c)$ . Since  $\text{Pid}_x \mathbf{m} = 0$  means

$$\sum_{j=0}^p \sum_{\nu=1}^{n_j} m_{j,\nu}^2 = (p-1)n^2 = \sum_{\nu=0}^{n_0} (p-1)nm_{0,\nu},$$

the Fuchs relation (6.16) is valid for any  $k$ . Then it follows from Lemma 6.1 that the Riemann scheme of the operator  $P_k(c_1, \dots, c_k) = P(k-1, c_k)P(k-$

$2, c_{k-1}) \cdots P(0, c_1)$  equals

$$(8.22) \quad \left\{ \begin{array}{ll} x = c_0 = \infty & x = c_j \ (j = 1, \dots, p) \\ [\lambda_{0,1}]_{(km_{0,1})} & [\lambda_{j,1}]_{(km_{j,1})} \\ \vdots & \vdots \\ [\lambda_{0,n_1}]_{(km_{0,n_1})} & [\lambda_{j,n_j}]_{(km_{j,n_j})} \end{array} \right\}$$

and it contain an independent accessory parameters in the coefficient of  $\nu n$ -th order term of  $P_k(c_1, \dots, c_k)$  for  $\nu = 0, \dots, k-1$  because for the proof of this statement we may assume  $\lambda_{j,\nu}$  are generic under the Fuchs relation.

Note that

$$N_\nu(k\mathbf{m}) = \begin{cases} 1 & (\nu \equiv n-1 \pmod{n}), \\ -1 & (\nu \equiv 0 \pmod{n}), \\ 0 & (\nu \not\equiv 0, n-1 \pmod{n}) \end{cases}$$

for  $\nu = 1, \dots, kn-1$  because

$$\widetilde{k\mathbf{m}} = \begin{cases} \{2i, 2i, 2i, 2i; i = 1, 2, \dots, k\} & \text{if } \mathbf{m} \text{ is of type } \tilde{D}_4, \\ \{ni, ni, ni, ni-2, ni-3, \dots, ni-n+1; i = 1, 2, \dots, k\} & \text{if } \mathbf{m} \text{ is of type } \tilde{E}_6, \tilde{E}_7 \text{ or } \tilde{E}_8 \end{cases}$$

under the notation (8.2) and (8.17). Then the operator  $P_k(c_1, \dots, c_k)$  shows that when we inductively determine the coefficients of the operator with the Riemann scheme (8.22) as in the proof of Theorem 8.6, we have a new accessory parameter in the coefficient of the  $((k-j)n)$ -th order term and then the conditions for the coefficients of the  $((k-j)n-1)$ -th order term are overdetermined but they are automatically compatible for  $j = 1, \dots, k-1$ .

Thus we can conclude that the operators of the normal form with the Riemann scheme (8.22) are  $P_k(c_1, \dots, c_k)$ , which are always reducible.  $\square$

**Proposition 8.12.** *Let  $k$  be a positive integer and let  $\mathbf{m}$  be an indivisible  $(p+1)$ -tuple of partitions of  $n$ . Suppose  $k\mathbf{m}$  is realizable and  $\text{idx } \mathbf{m} < 0$ . Then any Fuchsian differential equation with the Riemann scheme (8.22) is always irreducible if  $\lambda_{j,\nu}$  is generic under the Fuchs relation*

$$(8.23) \quad \sum_{j=0}^p \sum_{\nu=1}^{n_j} m_{j,\nu} \lambda_{j,\nu} = \text{ord } \mathbf{m} - k \frac{\text{idx } \mathbf{m}}{2}.$$

*Proof.* The above Fuchs relation follows from (6.32) with the identities  $\text{ord } k\mathbf{m} = k \text{ord } \mathbf{m}$  and  $\text{idx } k\mathbf{m} = k^2 \text{idx } \mathbf{m}$ .

Suppose  $Pu = 0$  is reducible. Then Remark 6.17 ii) says that there exist  $\mathbf{m}'$ ,  $\mathbf{m}'' \in \mathcal{P}$  such that  $k\mathbf{m} = \mathbf{m}' + \mathbf{m}''$  and  $0 < \text{ord } \mathbf{m}' < k \text{ord } \mathbf{m}$  and  $|\{\lambda_{\mathbf{m}'}\}| \in \{0, -1, -2, \dots\}$ . Suppose  $\lambda_{j,\nu}$  are generic under (8.23). Then the condition  $|\{\lambda_{\mathbf{m}'}\}| \in \mathbb{Z}$  implies  $\mathbf{m}' = \ell \mathbf{m}$  with a positive integer satisfying  $\ell < k$  and

$$\begin{aligned} |\{\lambda_{\ell \mathbf{m}}\}| &= \sum_{j=0}^p \sum_{\nu=1}^{n_j} \ell m_{j,\nu} \lambda_{j,\nu} - \text{ord } \ell \mathbf{m} + \ell^2 \text{idx } \mathbf{m} \\ &= \ell \left( \text{ord } \mathbf{m} - k \frac{\text{idx } \mathbf{m}}{2} \right) - \ell \text{ord } \mathbf{m} + \ell^2 \text{idx } \mathbf{m} \\ &= \ell(\ell - k) \text{idx } \mathbf{m} > 0. \end{aligned}$$

Hence  $|\lambda_{\mathbf{m}'}| > 0$ .  $\square$

8.4. **Universal model.** Now we have a main result in §8 which assures the existence of Fuchsian differential operators with given spectral types.

**Theorem 8.13.** Fix a tuple  $\mathbf{m} = (m_{j,\nu})_{\substack{0 \leq j \leq p \\ 1 \leq \nu \leq n_j}} \in \mathcal{P}_{p+1}^{(n)}$ .

i) Under the notation in Definitions 6.10, 6.16 and 7.6, the tuple  $\mathbf{m}$  is realizable if and only if there exists a non-negative integer  $K$  such that  $\partial_{max}^i \mathbf{m}$  are well-defined for  $i = 1, \dots, K$  and

$$(8.24) \quad \begin{aligned} \text{ord } \mathbf{m} &> \text{ord } \partial_{max} \mathbf{m} > \text{ord } \partial_{max}^2 \mathbf{m} > \dots > \text{ord } \partial_{max}^K \mathbf{m}, \\ d_{max}(\partial_{max}^K \mathbf{m}) &= 2 \text{ord } \partial_{max}^K \mathbf{m} \text{ or } d_{max}(\partial_{max}^K \mathbf{m}) \leq 0. \end{aligned}$$

ii) Fix complex numbers  $\lambda_{j,\nu}$ . If there exists an irreducible Fuchsian operator with the Riemann scheme (6.15) such that it is locally non-degenerate (cf. Definition 11.8), then  $\mathbf{m}$  is irreducibly realizable.

Here we note that if  $P$  is irreducible and  $\mathbf{m}$  is rigid,  $P$  is locally non-degenerate (cf. Definition 11.8).

Hereafter in this theorem we assume  $\mathbf{m}$  is realizable.

iii)  $\mathbf{m}$  is irreducibly realizable if and only if  $\mathbf{m}$  is indivisible or  $\text{idx } \mathbf{m} < 0$ .

iv) There exists a universal model  $P_{\mathbf{m}} u = 0$  associated with  $\mathbf{m}$  which has the following property.

Namely,  $P_{\mathbf{m}}$  is the Fuchsian differential operator of the form

$$(8.25) \quad \begin{aligned} P_{\mathbf{m}} &= \left( \prod_{j=1}^p (x - c_j)^n \right) \frac{d^n}{dx^n} + a_{n-1}(x) \frac{d^{n-1}}{dx^{n-1}} + \dots + a_1(x) \frac{d}{dx} + a_0(x), \\ a_j(x) &\in \mathbb{C}[\lambda_{j,\nu}, g_1, \dots, g_N] \end{aligned}$$

such that  $P_{\mathbf{m}}$  has regular singularities at  $p+1$  fixed points  $x = c_0 = \infty, c_1, \dots, c_p$  and the Riemann scheme of  $P_{\mathbf{m}}$  equals (6.15) for any  $g_i \in \mathbb{C}$  and  $\lambda_{j,\nu} \in \mathbb{C}$  under the Fuchs relation (6.16). Moreover the coefficients  $a_j(x)$  are polynomials of  $x$ ,  $\lambda_{j,\nu}$  and  $g_i$  with the degree at most  $(p-1)n + j$  for  $j = 0, \dots, n$ , respectively. Here  $g_i$  are called accessory parameters and we call  $P_{\mathbf{m}}$  the universal operator of type  $\mathbf{m}$ .

The non-negative integer  $N$  will be denoted by  $\text{Ridx } \mathbf{m}$  and given by

$$(8.26) \quad N = \text{Ridx } \mathbf{m} := \begin{cases} 0 & (\text{idx } \mathbf{m} > 0), \\ \text{gcd } \mathbf{m} & (\text{idx } \mathbf{m} = 0), \\ \text{Pidx } \mathbf{m} & (\text{idx } \mathbf{m} < 0). \end{cases}$$

Put  $\bar{\mathbf{m}} = (\bar{m}_{j,\nu})_{\substack{0 \leq j \leq p \\ 1 \leq \nu \leq n_j}} := \partial_{max}^K \mathbf{m}$  with the non-negative integer  $K$  given in i).

When  $\text{idx } \mathbf{m} \leq 0$ , we define

$$\begin{aligned} q_\ell^0 &:= \#\{i; \sum_{\nu=1}^{\bar{n}_0} \max\{\bar{m}_{0,\nu} - i, 0\} \geq \text{ord } \bar{\mathbf{m}} - \ell, i \geq 0\}, \\ I_{\mathbf{m}} &:= \{(j, \nu) \in \mathbb{Z}^2; q_\nu^0 \leq j \leq q_\nu^0 + N_\nu - 1, 1 \leq \nu \leq \text{ord } \bar{\mathbf{m}} - 1\}. \end{aligned}$$

When  $\text{idx } \mathbf{m} > 0$ , we put  $I_{\mathbf{m}} = \emptyset$ .

Then  $\#I_{\mathbf{m}} = \text{Ridx } \mathbf{m}$  and we can define  $I_i$  such that  $I_{\mathbf{m}} = \{I_i; i = 1, \dots, N\}$  and  $g_i$  satisfy (8.13) by putting  $g_{I_i} = g_i$  for  $i = 1, \dots, N$ .

v) Retain the notation in Definition 7.11. If  $\lambda_{j,\nu} \in \mathbb{C}$  satisfy

$$(8.27) \quad \begin{cases} \sum_{j=0}^p \lambda(k)_{j,\ell(k)_j + \delta_{j,j_0}(\nu_0 - \ell(k)_j)} \\ \notin \{0, -1, -2, -3, \dots, m(k)_{j_0, \ell(k)_{j_0}} - m(k)_{j_0, \nu_0} - d(k) + 2\} \\ \text{for any } k = 0, \dots, K-1 \text{ and } (j_0, \nu_0) \text{ satisfying} \\ m(k)_{j_0, \nu_0} \geq m(k)_{j_0, \ell(k)_{j_0}} - d(k) + 2, \end{cases}$$

any Fuchsian differential operator  $P$  of the normal form which has the Riemann scheme (6.15) belongs to  $P_{\mathbf{m}}$  with a suitable  $(g_1, \dots, g_N) \in \mathbb{C}^N$ .

(8.28)  $\left\{ \begin{array}{l} \text{If } \mathbf{m} \text{ is a scalar multiple of a fundamental tuple or simply reducible,} \\ (8.27) \text{ is always valid for any } \lambda_{j,\nu}. \end{array} \right.$

(8.29)  $\left\{ \begin{array}{l} \text{Fix } \lambda_{j,\nu} \in \mathbb{C}. \text{ Suppose there is an irreducible Fuchsian differential} \\ \text{operator with the Riemann scheme (6.15) such that the operator is} \\ \text{locally non-degenerate or } K \leq 1, \text{ then (8.27) is valid.} \end{array} \right.$

Suppose  $\mathbf{m}$  is monotone. Under the notation in §9.1, the condition (8.27) is equivalent to

$$(8.30) \quad \begin{aligned} &(\Lambda(\lambda)|\alpha) + 1 \notin \{0, -1, \dots, 2 - (\alpha|\alpha_{\mathbf{m}})\} \\ &\text{for any } \alpha \in \Delta(\mathbf{m}) \text{ satisfying } (\alpha|\alpha_{\mathbf{m}}) > 1. \end{aligned}$$

Example 7.5 gives a Fuchsian differential operator with the rigid spectral type 21, 21, 21, 21 which doesn't belong to the corresponding universal operator.

The fundamental tuple and the simply reducible are defined as follows.

**Definition 8.14.** i) (fundamental tuple) An irreducibly realizable tuple  $\mathbf{m} \in \mathcal{P}$  is called *fundamental* if  $\text{ord } \mathbf{m} = 1$  or  $d_{\max}(\mathbf{m}) \leq 0$ .

For an irreducibly realizable tuple  $\mathbf{m} \in \mathcal{P}$ , there exists a non-negative integer  $K$  such that  $\partial_{\max}^K \mathbf{m}$  is fundamental and satisfies (8.24). Then we call  $\partial_{\max}^K \mathbf{m}$  a fundamental tuple corresponding to  $\mathbf{m}$  and define  $f\mathbf{m} := \partial_{\max}^K \mathbf{m}$ .

ii) (simply reducible tuple) A tuple  $\mathbf{m}$  is *simply reducible* if there exists a positive integer  $K$  satisfying (8.24) and  $\text{ord } \partial_{\max}^K \mathbf{m} = \text{ord } \mathbf{m} - K$ .

*Proof of Theorem 8.13.* i) We have proved that  $\mathbf{m}$  is realizable if  $d_{\max}(\mathbf{m}) \leq 0$ . Note that the condition  $d_{\max}(\mathbf{m}) = 2 \text{ord } \mathbf{m}$  is equivalent to the fact that  $s\mathbf{m}$  is trivial. Hence Theorem 7.9 proves the claim.

iv) Now we use the notation in Definition 7.11. The existence of the universal operator is clear if  $s\mathbf{m}$  is trivial. If  $d_{\max}(\mathbf{m}) \leq 0$ , Theorem 8.6 and Proposition 8.11 with Corollary 8.3 assure the existence of the universal operator  $P_{\mathbf{m}}$  claimed in iii). Hence iii) is valid for the tuple  $\mathbf{m}(K)$  and we have a universal operator  $P_K$  with the Riemann scheme  $\{\lambda(K)_{\mathbf{m}(K)}\}$ .

The universal operator  $P_k$  with the Riemann scheme  $\{\lambda(k)_{\mathbf{m}(k)}\}$  are inductively obtained by applying  $\partial_{\ell(k)}$  to the universal operator  $P_{k+1}$  with the Riemann scheme  $\{\lambda(k+1)_{\mathbf{m}(k+1)}\}$  for  $k = K-1, K-2, \dots, 0$ . Since the claims in iii) such as (8.13) are kept by the operation  $\partial_{\ell(k)}$ , we have iv).

iii) Note that  $\mathbf{m}$  is irreducibly realizable if  $\mathbf{m}$  is indivisible (cf. Remark 6.17 ii)). Hence suppose  $\mathbf{m}$  is not indivisible. Put  $k = \text{gcd } \mathbf{m}$  and  $\mathbf{m} = k\mathbf{m}'$ . Then  $\text{idx } \mathbf{m} = k^2 \text{idx } \mathbf{m}'$ .

If  $\text{idx } \mathbf{m} > 0$ , then  $\text{idx } \mathbf{m} > 2$  and the inequality (7.19) in Lemma 7.3 implies that  $\mathbf{m}$  is not irreducibly realizable. If  $\text{idx } \mathbf{m} < 0$ , Proposition 8.12 assures that  $\mathbf{m}$  is irreducibly realizable.

Suppose  $\text{idx } \mathbf{m} = 0$ . Then the universal operator  $P_{\mathbf{m}}$  has  $k$  accessory parameters. Using the argument in the first part of the proof of Proposition 8.11, we can construct a Fuchsian differential operator  $\tilde{P}_{\mathbf{m}}$  with the Riemann scheme  $\{\lambda_{\mathbf{m}}\}$ . Since  $\tilde{P}_{\mathbf{m}}$  is a product of  $k$  copies of the universal operator  $P_{\overline{\mathbf{m}}}$  and it has  $k$  accessory parameters, the operator  $P_{\mathbf{m}}$  coincides with the reducible operator  $\tilde{P}_{\mathbf{m}}$  and hence  $\mathbf{m}$  is not irreducibly realizable.

v) Fix  $\lambda_{j,\nu} \in \mathbb{C}$ . Let  $P$  be a Fuchsian differential operator with the Riemann scheme  $\{\lambda_{\mathbf{m}}\}$ . Suppose  $P$  is of the normal form.

Theorem 8.6 and Proposition 8.11 assure that  $P$  belongs to  $P_{\mathbf{m}}$  if  $K = 0$ .

Theorem 7.2 proves that if  $\partial_{max}^k P$  has the Riemann scheme  $\{\lambda(k)_{\mathbf{m}(k)}\}$  and (8.27) is valid, then  $\partial_{max}^{k+1} P = \partial_{\ell(k)} \partial_{max}^k P$  is well-defined and has the Riemann scheme  $\{\lambda(k+1)_{\mathbf{m}(k+1)}\}$  for  $k = 0, \dots, K-1$  and hence it follows from (7.26) that  $P$  belongs to the universal operator  $P_{\mathbf{m}}$  because  $\partial_{max}^K P$  belongs to the universal operator  $P_{\mathbf{m}(K)}$ .

If  $\mathbf{m}$  is simply reducible,  $d(k) = 1$  and therefore (8.27) is valid because  $m(k)_{j,\nu} \leq m(k)_{j,\ell(k)\nu} < m(k)_{j,\ell(k)\nu} - d(k) + 2$  for  $j = 0, \dots, p$  and  $\nu = 1, \dots, n_j$  and  $k = 0, \dots, K-1$ .

The equivalence of the conditions (8.27) and (8.30) follows from the argument in §9.1, Proposition 9.9 and Theorem 12.13.

ii) Suppose there exists an irreducible operator  $P$  with the Riemann scheme (6.15). Let  $\mathbf{M} = (M_0, \dots, M_p)$  be the tuple of monodromy generators of the equation  $Pu = 0$  and put  $\mathbf{M}(0) = \mathbf{M}$ . Let  $\mathbf{M}(k+1)$  be the tuple of matrices applying the operations in §11.1 to  $\mathbf{M}(k)$  corresponding to the operations  $\partial_{\ell(k)}$  for  $k = 0, 1, 2, \dots$

Comparing the operations on  $\mathbf{M}(k)$  and  $\partial_{\ell(k)}$ , we can conclude that there exists a non-negative integer  $K$  satisfying the claim in i). In fact Theorem 11.3 proves that  $\mathbf{M}(k)$  are irreducible, which assures that the conditions (7.6) and (7.7) corresponding to the operations  $\partial_{\ell(k)}$  are always valid (cf. Corollary 12.12). Therefore  $\mathbf{m}$  is realizable and moreover we can conclude that (8.29) implies (8.27). If  $\text{idx } \mathbf{m}$  is divisible and  $\text{idx } \mathbf{m} = 0$ , then  $P_{\mathbf{m}}$  is reducible for any fixed parameters  $\lambda_{j,\nu}$  and  $g_i$ . Hence  $\mathbf{m}$  is irreducibly realizable.  $\square$

*Remark 8.15.* i) The uniqueness of the universal operator in Theorem 8.13 is obvious. But it is not valid in the case of systems of Schlesinger canonical form (cf. Example 11.2).

ii) The assumption that  $Pu = 0$  is locally non-degenerate seems to be not necessary in Theorem 8.13 ii) and (8.29). When  $K = 1$ , this is clear from the proof of the theorem. For example, the rigid irreducible operator with the spectral type 31, 31, 31, 31, 31 belongs to the universal operator of type 211, 31, 31, 31, 31.

**8.5. Simply reducible spectral type.** In this subsection we characterize the tuples of the simply reducible spectral type.

**Proposition 8.16.** i) *A realizable tuple  $\mathbf{m} \in \mathcal{P}^{(n)}$  satisfying  $m_{0,\nu} = 1$  for  $\nu = 1, \dots, n$  is simply reducible if  $\mathbf{m}$  is not fundamental.*

ii) *The simply reducible rigid tuple corresponds to the tuple in Simpson's list (cf. §15.2) or it is isomorphic to 21111, 222, 33.*

iii) *Suppose  $\mathbf{m} \in \mathcal{P}_{p+1}$  is not fundamental. Then  $\mathbf{m}$  satisfies the condition  $N_\nu(\mathbf{m}) \geq 0$  for  $\nu = 2, \dots, \text{ord } \mathbf{m} - 1$  in Definition 8.1 if and only if  $\mathbf{m}$  is realizable and simply reducible.*

iv) *Let  $\mathbf{m} \in \mathcal{P}_{p+1}$  be a realizable monotone tuple. Suppose  $\mathbf{m}$  is indivisible and not fundamental. Then under the notation in §9.1,  $\mathbf{m}$  is simply reducible if and only if*

$$(8.31) \quad (\alpha | \alpha_{\mathbf{m}}) = 1 \quad (\forall \alpha \in \Delta(\mathbf{m})),$$

namely  $[\Delta(\mathbf{m})] = 1^{\#\Delta(\mathbf{m})}$  (cf. Remark 9.11 ii)).

*Proof.* i) The claim is obvious from the definition.

ii) Let  $\mathbf{m}'$  be a simply reducible rigid tuple. We have only to prove that  $\mathbf{m} = \partial_{max} \mathbf{m}'$  is in the Simpson's list or 21111, 222, 33 and  $\text{ord } \mathbf{m}' = \text{ord } \mathbf{m} + 1$  and  $d_{max}(\mathbf{m}) = 1$ , then  $\mathbf{m}'$  is in Simpson's list or 21111, 222, 33. The condition  $\text{ord } \mathbf{m}' = \text{ord } \mathbf{m} + 1$  implies  $\mathbf{m} \in \mathcal{P}_3$ . We may assume  $\mathbf{m}$  is monotone and  $\mathbf{m}' = \partial_{\ell_0, \ell_1, \ell_2} \mathbf{m}$ . The condition  $\text{ord } \mathbf{m}' = \text{ord } \mathbf{m} + 1$  also implies

$$(m_{0,1} - m_{0,\ell_0}) + (m_{1,1} - m_{1,\ell_0}) + (m_{2,1} - m_{2,\ell_0}) = 2.$$

Since  $\partial_{max} \mathbf{m}' = \mathbf{m}$ , we have  $m_{j,\ell_j} \geq m_{j,1} - 1$  for  $j = 0, 1, 2$ . Hence there exists an integer  $k$  with  $0 \leq k \leq 2$  such that  $m_{j,\ell_j} = m_{j,1} - 1 + \delta_{j,k}$  for  $j = 0, 1, 2$ . Then the following claims are easy, which assures the proposition.

If  $\mathbf{m} = 11, 11, 11$ ,  $\mathbf{m}'$  is isomorphic to  $1^3, 1^3, 21$ .

If  $\mathbf{m} = 1^3, 1^3, 21$ ,  $\mathbf{m}'$  is isomorphic to  $1^4, 1^4, 31$  or  $1^4, 211, 22$ .

If  $\mathbf{m} = 1^n, 1^n, n - 11$  with  $n \geq 4$ ,  $\mathbf{m}' = 1^{n+1}, 1^{n+1}, n1$ .

If  $\mathbf{m} = 1^{2n}, nn - 11, nn$  with  $n \geq 2$ ,  $\mathbf{m}' = 1^{2n+1}, nn1, n + 1n$ .

If  $\mathbf{m} = 1^5, 221, 32$ , then  $\mathbf{m}' = 1^6, 33, 321$  or  $1^6, 222, 42$  or  $21111, 222, 33$ .

If  $\mathbf{m} = 1^{2n+1}, n + 1n, nn1$  with  $n \geq 3$ ,  $\mathbf{m}' = 1^{2n+2}, n + 1n + 1, n + 1n1$ .

If  $\mathbf{m} = 1^6, 222, 42$  or  $\mathbf{m} = 21111, 222, 33$ ,  $\mathbf{m}'$  doesn't exist.

iii) Note that Theorem 8.6 assures that the condition  $N_\nu(\mathbf{m}) \geq 0$  for  $\nu = 1, \dots, \text{ord } \mathbf{m} - 1$  implies that  $\mathbf{m}$  is realizable.

We may assume  $\mathbf{m} \in \mathcal{P}_{p+1}^{(n)}$  is standard. Put  $d = m_{0,1} + \dots + m_{p,1} - (p-1)n > 0$  and  $\mathbf{m}' = \partial_{max} \mathbf{m}$ . Then  $m'_{j,\nu} = m_{j,\nu} - \delta_{\nu,1}d$  for  $j = 0, \dots, p$  and  $\nu \geq 1$ . Under the notation in Definition 8.1 the operation  $\partial_{max}$  transforms the sets

$$\mathbf{m}_j := \{\tilde{m}_{j,k}; k = 0, 1, 2, \dots \text{ and } \tilde{m}_{j,k} > 0\}$$

into

$$\mathbf{m}'_j = \{\tilde{m}_{j,k} - \min\{d, m_{j,1} - k\}; k = 0, \dots, \max\{m_{j,1} - d, m_{j,2} - 1\}\},$$

respectively because  $\tilde{m}_{j,i} = \sum_\nu \max\{m_{j,\nu} - i, 0\}$ . Therefore  $N_\nu(\mathbf{m}') \leq N_\nu(\mathbf{m})$  for  $\nu = 1, \dots, n - d - 1 = \text{ord } \mathbf{m}' - 1$ . Here we note that

$$\sum_{\nu=1}^{n-1} N_\nu(\mathbf{m}) = \sum_{\nu=1}^{n-d-1} N_\nu(\mathbf{m}') = \text{Pid } \mathbf{m}.$$

Hence  $N_\nu(\mathbf{m}) \geq 0$  for  $\nu = 1, \dots, n - 1$  if and only if  $N_\nu(\mathbf{m}') = N_\nu(\mathbf{m})$  for  $\nu = 1, \dots, (n - d) - 1$  and moreover  $N_\nu(\mathbf{m}) = 0$  for  $\nu = n - d, \dots, n - 1$ . Note that the condition that  $N_\nu(\mathbf{m}') = N_\nu(\mathbf{m})$  for  $\nu = 1, \dots, (n - d) - 1$  equals

$$(8.32) \quad m_{j,1} - d \geq m_{j,2} - 1 \quad \text{for } j = 0, \dots, p.$$

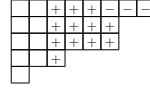

This is easy to see by using a Young diagram. For example, when  $\{8, 6, 6, 3, 1\} = \{m_{0,1}, m_{0,2}, m_{0,3}, m_{0,4}, m_{0,5}\}$  is a partition of  $n = 24$ , the corresponding Young diagram is as above and then  $\tilde{m}_{0,2}$  equals 15, namely, the number of boxes with the sign + or -. Moreover when  $d = 3$ , the boxes with the sign - are deleted by  $\partial_{max}$  and the number  $\tilde{m}_{0,2}$  changes into 12. In this case  $m_0 = \{24, 19, 15, 11, 8, 5, 2, 1\}$  and  $m'_0 = \{21, 16, 12, 8, 5, 2\}$ .

If  $d \geq 2$ , then  $1 \in \mathbf{m}_j$  for  $j = 0, \dots, p$  and therefore  $N_{n-2}(\mathbf{m}) - N_{n-1}(\mathbf{m}) = 2$ , which means  $N_{n-1}(\mathbf{m}) \neq 0$  or  $N_{n-2}(\mathbf{m}) \neq 0$ . When  $d = 1$ , we have  $N_\nu(\mathbf{m}) = N_\nu(\mathbf{m}')$  for  $\nu = 1, \dots, n - 2$  and  $N_{n-1}(\mathbf{m}) = 0$ . Thus we have the claim.

iv) The claim follows from Proposition 9.9.  $\square$

**Example 8.17.** We show the simply reducible tuples with index 0 whose fundamental tuple is of type  $\tilde{D}_4, \tilde{E}_6, \tilde{E}_7$  or  $\tilde{E}_8$  (cf. Example 8.8).

$\tilde{D}_4$ : 21, 21, 21, 111 22, 22, 31, 211 22, 31, 31, 1111

$\tilde{E}_6$ : 211, 211, 1111 221, 221, 2111 221, 311, 11111 222, 222, 3111 222, 321, 2211  
222, 411, 111111 322, 331, 2221 332, 431, 2222 333, 441, 3222

$\tilde{E}_7$ : 11111, 2111, 32 111111, 2211, 42 21111, 2211, 33 111111, 3111, 33  
22111, 2221, 43 1111111, 2221, 52 22211, 2222, 53 11111111, 2222, 62  
32111, 2222, 44 22211, 3221, 53

$\tilde{E}_8$ : 1111111, 322, 43 11111111, 332, 53 2111111, 332, 44 11111111, 422, 44  
2211111, 333, 54 111111111, 333, 63 2221111, 433, 55 2222111, 443, 65  
3222111, 444, 66 2222211, 444, 75 2222211, 543, 66 2222221, 553, 76

2222222, 653, 77

In general we have the following proposition.

**Proposition 8.18.** *There exist only a finite number of standard and simply reducible tuples with any fixed non-positive index of rigidity.*

*Proof.* First note that  $\mathbf{m} \in \mathcal{P}_{p+1}$  if  $d_{max}(\mathbf{m}) = 1$  and  $\text{ord } \mathbf{m} > 3$  and  $\partial_{max} \mathbf{m} \in \mathcal{P}_{p+1}$ . Since there exist only finite basic tuples with any fixed index of rigidity (cf. Remark 9.15), we have only to prove the non-existence of the infinite sequence

$$\mathbf{m}(0) \xleftarrow{\partial_{max}} \mathbf{m}(1) \xleftarrow{\partial_{max}} \dots \xleftarrow{\partial_{max}} \mathbf{m}(k) \xleftarrow{\partial_{max}} \mathbf{m}(k+1) \xleftarrow{\partial_{max}} \dots$$

such that  $d_{max}(\mathbf{m}(k)) = 1$  for  $k \geq 1$  and  $\text{idx } \mathbf{m}(0) \leq 0$ .

Put

$$\begin{aligned} \bar{m}(k)_j &= \max_{\nu} \{m(k)_{j,\nu}\}, \\ a(k)_j &= \#\{\nu; m(k)_{j,\nu} = \bar{m}(k)_j\}, \\ b(k)_j &= \begin{cases} \#\{\nu; m(k)_{j,\nu} = \bar{m}(k)_j - 1\} & (\bar{m}(k)_j > 1), \\ \infty & (\bar{m}(k)_j = 1). \end{cases} \end{aligned}$$

The assumption  $d_{max}(\mathbf{m}(k)) = d_{max}(\mathbf{m}(k+1)) = 1$  implies that there exist indices  $0 \leq j_k < j'_k$  such that

$$(8.33) \quad (a(k+1)_j, b(k+1)_j) = \begin{cases} (a(k)_j + 1, b(k)_j - 1) & (j = j_k \text{ or } j'_k), \\ (1, a(k)_j - 1) & (j \neq j_k \text{ and } j'_k) \end{cases}$$

and

$$(8.34) \quad \bar{m}(k)_0 + \dots + \bar{m}(k)_p = (p-1) \text{ord } \mathbf{m}(k) + 1 \quad (p \gg 1)$$

for  $k = 1, 2, \dots$ . Since  $a(k+1)_j + b(k+1)_j \leq a(k)_j + b(k)_j$ , there exists a positive integer  $N$  such that  $a(k+1)_j + b(k+1)_j = a(k)_j + b(k)_j$  for  $k \geq N$ , which means

$$(8.35) \quad b(k)_j \begin{cases} > 0 & (j = j_k \text{ or } j'_k), \\ = 0 & (j \neq j_k \text{ and } j'_k). \end{cases}$$

Putting  $(a_j, b_j) = (a(N)_j, b(N)_j)$ , we may assume  $b_0 \geq b_1 > b_2 = b_3 = \dots = 0$  and  $a_2 \geq a_3 \geq \dots$ . Moreover we may assume  $j'_{N+1} \leq 3$ , which means  $a_j = 1$  for  $j \geq 4$ . Then the relations (8.33) and (8.35) for  $k = N, N+1, N+2$  and  $N+3$  prove that  $((a_0, b_0), \dots, (a_3, b_3))$  is one of the followings:

$$(8.36) \quad ((a_0, \infty), (a_1, \infty), (1, 0), (1, 0)),$$

$$(8.37) \quad ((a_0, \infty), (1, 1), (2, 0), (1, 0)),$$

$$(8.38) \quad ((2, 2), (1, 1), (4, 0), (1, 0)), ((1, 3), (3, 1), (2, 0), (1, 0)),$$

$$(8.39) \quad ((1, 2), (2, 1), (3, 0), (1, 0)),$$

$$(8.40) \quad ((1, 1), (1, 1), (2, 0), (2, 0)).$$

In fact if  $b_1 > 1$ ,  $a_2 = a_3 = 1$  and we have (8.36). Thus we may assume  $b_1 = 1$ . If  $b_0 = \infty$ ,  $a_3 = 1$  and we have (8.37). If  $b_0 = b_1 = 1$ , we have easily (8.40). Thus we may moreover assume  $b_1 = 1 < b_0 < \infty$  and  $a_3 = 1$ . In this case the integers  $j''_k$  satisfying  $b(k)_{j''_k} = 0$  and  $0 \leq j''_k \leq 2$  for  $k \geq N$  are uniquely determined and we have easily (8.38) or (8.39).

Put  $n = \text{ord } \mathbf{m}(N)$ . We may suppose  $\mathbf{m}(N)$  is standard. Let  $p$  be an integer such that  $m_{j,0} < n$  if and only if  $j \leq p$ . Note that  $p \geq 2$ . Then if  $\mathbf{m}(N)$  satisfies (8.36) (resp. (8.37)), (8.34) implies  $\mathbf{m}(N) = 1^n, 1^n, n-11$  (resp.  $1^n, mm-11, mm$  or  $1^n, m+1m, mm1$ ) and  $\mathbf{m}(N)$  is rigid.

Suppose one of (8.38)–(8.40). Then it is easy to check that  $\mathbf{m}(N)$  doesn't satisfy (8.34). For example, suppose (8.39). Then  $3m_{0,1} - 2 \leq n$ ,  $3m_{1,1} - 1 \leq n$  and  $3m_{2,1} \leq n$  and we have  $m_{0,1} + m_{1,1} + m_{2,1} \leq [\frac{n+2}{3}] + [\frac{n+1}{3}] + [\frac{n}{3}] = n$ , which contradicts to (8.34). The relations  $[\frac{n+2}{4}] + [\frac{n}{2}] + [\frac{n}{4}] \leq n$  and  $2[\frac{n+1}{2}] + 2[\frac{n}{2}] = 2n$  assure the same conclusion in the other cases.  $\square$

## 9. A KAC-MOODY ROOT SYSTEM

**9.1. Correspondence with a Kac-Moody root system.** We review a Kac-Moody root system to describe the combinatorial structure of middle convolutions on the spectral types. Its relation to Deligne-Simpson problem is first clarified by [CB].

Let

$$(9.1) \quad I := \{0, (j, \nu); j = 0, 1, \dots, \nu = 1, 2, \dots\}.$$

be a set of indices and let  $\mathfrak{h}$  be an infinite dimensional real vector space with the set of basis  $\Pi$ , where

$$(9.2) \quad \Pi = \{\alpha_i; i \in I\} = \{\alpha_0, \alpha_{j,\nu}; j = 0, 1, 2, \dots, \nu = 1, 2, \dots\}.$$

Put

$$(9.3) \quad I' := I \setminus \{0\}, \quad \Pi' := \Pi \setminus \{\alpha_0\},$$

$$(9.4) \quad Q := \sum_{\alpha \in \Pi} \mathbb{Z}\alpha \supset Q_+ := \sum_{\alpha \in \Pi} \mathbb{Z}_{\geq 0}\alpha.$$

We define an indefinite symmetric bilinear form on  $\mathfrak{h}$  by

$$(9.5) \quad \begin{aligned} (\alpha|\alpha) &= 2 & (\alpha \in \Pi), \\ (\alpha_0|\alpha_{j,\nu}) &= -\delta_{\nu,1}, \\ (\alpha_{i,\mu}|\alpha_{j,\nu}) &= \begin{cases} 0 & (i \neq j \text{ or } |\mu - \nu| > 1), \\ -1 & (i = j \text{ and } |\mu - \nu| = 1). \end{cases} \end{aligned}$$

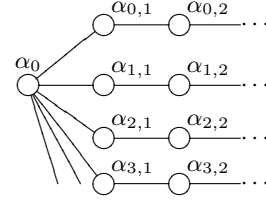

The element of  $\Pi$  is called the *simple root* of a Kac-Moody root system and the *Weyl group*  $W_\infty$  of this Kac-Moody root system is generated by the *simple reflections*  $s_i$  with  $i \in I$ . Here the *reflection* with respect to an element  $\alpha \in \mathfrak{h}$  satisfying  $(\alpha|\alpha) \neq 0$  is the linear transformation

$$(9.6) \quad s_\alpha : \mathfrak{h} \ni x \mapsto x - 2 \frac{(x|\alpha)}{(\alpha|\alpha)} \alpha \in \mathfrak{h}$$

and

$$(9.7) \quad s_i = s_{\alpha_i} \text{ for } i \in I.$$

In particular  $s_i(x) = x - (\alpha_i|x)\alpha_i$  for  $i \in I$  and the subgroup of  $W_\infty$  generated by  $s_i$  for  $i \in I \setminus \{0\}$  is denoted by  $W'_\infty$ .

The Kac-Moody root system is determined by the set of simple roots  $\Pi$  and its Weyl group  $W_\infty$  and it is denoted by  $(\Pi, W_\infty)$ .

Denoting  $\sigma(\alpha_0) = \alpha_0$  and  $\sigma(\alpha_{j,\nu}) = \alpha_{\sigma(j),\nu}$  for  $\sigma \in \mathfrak{S}_\infty$ , we put

$$(9.8) \quad \widetilde{W}_\infty := \mathfrak{S}_\infty \times W_\infty,$$

which is an automorphism group of the root system.

*Remark 9.1* ([Kc]). The set  $\Delta^{re}$  of *real roots* equals the  $W_\infty$ -orbit of  $\Pi$ , which also equals  $W_\infty \alpha_0$ . Denoting

$$(9.9) \quad B := \{\beta \in Q_+; \text{supp } \beta \text{ is connected and } (\beta, \alpha) \leq 0 \text{ } (\forall \alpha \in \Pi)\},$$



the set of *positive imaginary roots*  $\Delta_+^{im}$  equals  $W_\infty B$ . Here

$$(9.10) \quad \text{supp } \beta := \{\alpha \in \Pi; n_\alpha \neq 0\} \quad \text{if } \beta = \sum_{\alpha \in \Pi} n_\alpha \alpha.$$

The set  $\Delta$  of roots equals  $\Delta^{re} \cup \Delta^{im}$  by denoting  $\Delta_-^{im} = -\Delta_+^{im}$  and  $\Delta^{im} = \Delta_+^{im} \cup \Delta_-^{im}$ . Put  $\Delta_+ = \Delta \cap Q_+$ ,  $\Delta_- = -\Delta_+$ ,  $\Delta_+^{re} = \Delta^{re} \cap Q_+$  and  $\Delta_-^{re} = -\Delta_+^{re}$ . Then  $\Delta = \Delta_+ \cup \Delta_-$ ,  $\Delta_+^{im} \subset \Delta_+$  and  $\Delta^{re} = \Delta_+^{re} \cup \Delta_-^{re}$ . The root in  $\Delta$  is called *positive* if and only if  $\alpha \in Q_+$ .

A subset  $L \subset \Pi$  is called *connected* if the decomposition  $L_1 \cup L_2 = L$  with  $L_1 \neq \emptyset$  and  $L_2 \neq \emptyset$  always implies the existence of  $v_j \in L_j$  satisfying  $(v_1 | v_2) \neq 0$ . Note that  $\text{supp } \alpha \ni \alpha_0$  for  $\alpha \in \Delta^{im}$ .

The subset  $L$  is called *classical* if it corresponds to the classical Dynkin diagram, which is equivalent to the condition that the group generated by the reflections with respect to the elements in  $L$  is a finite group.

The connected subset  $L$  is called *affine* if it corresponds to affine Dynkin diagram and in our case it corresponds to  $\tilde{D}_4$  or  $\tilde{E}_6$  or  $\tilde{E}_7$  or  $\tilde{E}_8$  with the following Dynkin diagram, respectively.

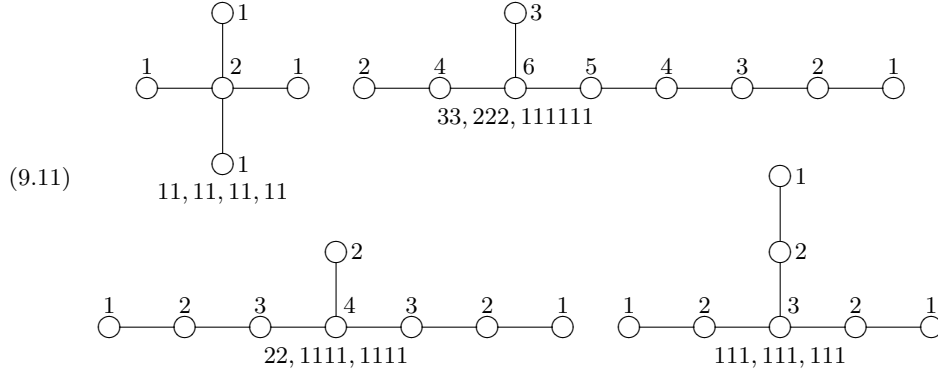

Here the circle correspond to simple roots and the numbers attached to simple roots are the coefficients  $n$  and  $n_{j,\nu}$  in the expression (9.15) of a root  $\alpha$ .

For a tuple of partitions  $\mathbf{m} = (m_{j,\nu})_{j \geq 0, \nu \geq 1} \in \mathcal{P}^{(n)}$ , we define

$$(9.12) \quad \begin{aligned} n_{j,\nu} &:= m_{j,\nu+1} + m_{j,\nu+2} + \cdots, \\ \alpha_{\mathbf{m}} &:= n\alpha_0 + \sum_{j=0}^{\infty} \sum_{\nu=1}^{\infty} n_{j,\nu} \alpha_{j,\nu} \in Q_+, \\ \kappa(\alpha_{\mathbf{m}}) &:= \mathbf{m}. \end{aligned}$$

As is given in [O6, Proposition 2.22] we have

**Proposition 9.2.** i)  $\text{idx}(\mathbf{m}, \mathbf{m}') = (\alpha_{\mathbf{m}} | \alpha_{\mathbf{m}'})$ .  
ii) Given  $i \in I$ , we have  $\alpha_{\mathbf{m}'} = s_i(\alpha_{\mathbf{m}})$  with

$$\mathbf{m}' = \begin{cases} \partial \mathbf{m} & (i = 0), \\ (m_{0,1} \dots, m_{j,1} \dots, \underset{\nu}{m_{j,\nu+1}} \underset{\nu+1}{m_{j,\nu}} \dots, \dots) & (i = (j, \nu)). \end{cases}$$

Moreover for  $\ell = (\ell_0, \ell_1, \dots) \in \mathbb{Z}_{>0}^\infty$  satisfying  $\ell_\nu = 1$  for  $\nu \gg 1$  we have

$$(9.13) \quad \alpha_\ell := \alpha_{\mathbf{1}_\ell} = \alpha_0 + \sum_{j=0}^{\infty} \sum_{\nu=1}^{\ell_j-1} \alpha_{j,\nu} = \left( \prod_{j \geq 0} s_{j,\ell_j-1} \cdots s_{j,2} s_{j,1} \right) (\alpha_0),$$

$$(9.14) \quad \alpha_{\partial_\ell(\mathbf{m})} = s_{\alpha_\ell}(\alpha_{\mathbf{m}}) = \alpha_{\mathbf{m}} - 2 \frac{(\alpha_{\mathbf{m}}|\alpha_\ell)}{(\alpha_\ell|\alpha_\ell)} \alpha_\ell = \alpha_{\mathbf{m}} - (\alpha_{\mathbf{m}}|\alpha_\ell) \alpha_\ell.$$

Note that

$$(9.15) \quad \begin{aligned} \alpha &= n\alpha_0 + \sum_{j \geq 0} \sum_{\nu \geq 1} n_{j,\nu} \alpha_{j,\nu} \in \Delta^+ \text{ with } n > 0 \\ &\Rightarrow n \geq n_{j,1} \geq n_{j,2} \geq \cdots \quad (j = 0, 1, \dots). \end{aligned}$$

In fact, for a sufficiently large  $K \in \mathbb{Z}_{>0}$ , we have  $n_{j,\mu} = 0$  for  $\mu \geq K$  and

$$s_{\alpha_{j,\nu} + \alpha_{j,\nu+1} + \cdots + \alpha_{j,K}} \alpha = \alpha + (n_{j,\nu-1} - n_{j,\nu})(\alpha_{j,\nu} + \alpha_{j,\nu+1} + \cdots + \alpha_{j,K}) \in \Delta^+$$

for  $\alpha \in \Delta_+$  in (9.15), which means  $n_{j,\nu-1} \geq n_{j,\nu}$  for  $\nu \geq 1$ . Here we put  $n_{j,0} = n$  and  $\alpha_{j,0} = \alpha_0$ . Hence for  $\alpha \in \Delta_+$  with  $\text{supp } \alpha \ni \alpha_0$ , there uniquely exists  $\mathbf{m} \in \mathcal{P}$  satisfying  $\alpha = \alpha_{\mathbf{m}}$ .

It follows from (9.14) that under the identification  $\mathcal{P} \subset Q_+$  with (9.12), our operation  $\partial_\ell$  corresponds to the reflection with respect to the root  $\alpha_\ell$ . Moreover the rigid (resp. indivisible realizable) tuple of partitions corresponds to the positive real root (resp. indivisible positive root) whose support contains  $\alpha_0$ , which were first established by [CB] in the case of Fuchsian systems of Schlesinger canonical form (cf. [O6]).

The corresponding objects with this identification are as follows, which will be clear in this subsection. Some of them are also explained in [O6].

$\mathcal{P}$	Kac-Moody root system
$\mathbf{m}$	$\alpha_{\mathbf{m}}$ (cf. (9.12))
$\mathbf{m}$ : monotone	$\alpha \in Q_+ : (\alpha \beta) \leq 0 \quad (\forall \beta \in \Pi')$
$\mathbf{m}$ : realizable	$\alpha \in \bar{\Delta}_+$
$\mathbf{m}$ : rigid	$\alpha \in \Delta_+^{re} : \text{supp } \alpha \ni \alpha_0$
$\mathbf{m}$ : monotone and fundamental	$\alpha \in Q_+ : \alpha = \alpha_0 \text{ or } (\alpha \beta) \leq 0 \quad (\forall \beta \in \Pi)$
$\mathbf{m}$ : irreducibly realizable	$\alpha \in \Delta_+, \text{ supp } \alpha \ni \alpha_0$ indivisible or $(\alpha \alpha) < 0$
$\mathbf{m}$ : basic and monotone	$\alpha \in Q_+ : (\alpha \beta) \leq 0 \quad (\forall \beta \in \Pi)$ indivisible
$\mathbf{m}$ : simply reducible and monotone	$\alpha \in \Delta_+ : (\alpha \alpha_{\mathbf{m}}) = 1 \quad (\forall \alpha \in \Delta(\mathbf{m}))$ $\alpha_0 \in \Delta(\mathbf{m}), \quad (\alpha \beta) \leq 0 \quad (\forall \beta \in \Pi')$
ord $\mathbf{m}$	$n_0 : \alpha = n_0 \alpha_0 + \sum_{i,\nu} n_{i,\nu} \alpha_{i,\nu}$
idx( $\mathbf{m}, \mathbf{m}'$ )	$(\alpha_{\mathbf{m}} \alpha_{\mathbf{m}'})$
idx $\mathbf{m}$	$(\alpha_{\mathbf{m}} \alpha_{\mathbf{m}})$
$d_\ell(\mathbf{m})$ (cf. (7.24))	$(\alpha_\ell \alpha_{\mathbf{m}})$ (cf. (9.13))
Pidx $\mathbf{m} + \text{Pidx } \mathbf{m}' = \text{Pidx}(\mathbf{m} + \mathbf{m}')$	$(\alpha_{\mathbf{m}} \alpha_{\mathbf{m}'}) = -1$
$(\nu, \nu+1) \in G_j \subset S'_\infty$ (cf. (6.30))	$s_{j,\nu} \in W'_\infty$ (cf. (9.7))
$H \simeq \mathfrak{S}_\infty$ (cf. (6.30))	$\mathfrak{S}_\infty$ in (9.8)
$\partial_{\mathbf{1}}$	$s_0$

$\partial_\ell$	$s_{\alpha_\ell}$ (cf. (9.13))
$\langle \partial_{\mathbf{1}}, S_\infty \rangle$	$\widetilde{W}_\infty$ (cf. (9.8))
$\{\lambda_{\mathbf{m}}\}$	$(\Lambda(\lambda), \alpha_{\mathbf{m}})$ (cf. (9.18))
$ \{\lambda_{\mathbf{m}}\} $	$(\Lambda(\lambda) + \frac{1}{2}\alpha_{\mathbf{m}} \alpha_{\mathbf{m}})$
$\text{Ad}((x - c_j)^\tau)$	$+\tau\Lambda_{0,j}^0$ (cf. (9.18))

Here

$$(9.16) \quad \overline{\Delta}_+ := \{k\alpha; \alpha \in \Delta_+, k \in \mathbb{Z}_{>0}, \text{supp } \alpha \ni \alpha_0\},$$

$\Delta(\mathbf{m}) \subset \Delta_+^{re}$  is given in (9.30) and  $\Lambda(\lambda) \in \overline{\mathfrak{h}}_p$  is defined as follows.

**Definition 9.3.** Fix a positive integer  $p$  which may be  $\infty$ . Put

$$(9.17) \quad I_p := \{0, (j, \nu); j = 0, 1, \dots, p, \nu = 1, 2, \dots\} \subset I$$

for a positive integer  $p$  and  $I_\infty = I$ .

Let  $\mathfrak{h}_p$  be the  $\mathbb{R}$ -vector space of finite linear combinations the elements of  $\Pi_p := \{\alpha_i; i \in \Pi_p\}$  and let  $\mathfrak{h}_p^\vee$  be the  $\mathbb{C}$ -vector space whose elements are linear combinations of infinite or finite elements of  $\Pi_p$ , which is identified with  $\Pi_{i \in I_p} \mathbb{C}\alpha_i$  and contains  $\mathfrak{h}_p$ .

The element  $\Lambda \in \mathfrak{h}_p^\vee$  naturally defines a linear form of  $\mathfrak{h}_p$  by  $(\Lambda | \cdot)$  and the group  $\widetilde{W}_\infty$  acts on  $\mathfrak{h}_p^\vee$ . If  $p = \infty$ , we assume that the element  $\Lambda = \xi_0\alpha_0 + \sum \xi_{j,\nu}\alpha_{j,\nu} \in \mathfrak{h}_\infty^\vee$  always satisfies  $\xi_{j,1} = 0$  for sufficiently large  $j \in \mathbb{Z}_{\geq 0}$ . Hence we have naturally  $\mathfrak{h}_p^\vee \subset \mathfrak{h}_{p+1}^\vee$  and  $\mathfrak{h}_\infty^\vee = \bigcup_{j \geq 0} \mathfrak{h}_j^\vee$ .

Define the elements of  $\mathfrak{h}_p^\vee$ :

$$(9.18) \quad \begin{aligned} \Lambda_0 &:= \frac{1}{2}\alpha_0 + \frac{1}{2} \sum_{j=0}^p \sum_{\nu=1}^{\infty} (1-\nu)\alpha_{j,\nu}, \\ \Lambda_{j,\nu} &:= \sum_{i=\nu+1}^{\infty} (i-\nu)\alpha_{j,i} \quad (j = 0, \dots, p, \nu = 0, 1, 2, \dots) \\ \Lambda^0 &:= 2\Lambda_0 - 2\Lambda_{0,0} = \alpha_0 + \sum_{\nu=1}^{\infty} (1+\nu)\alpha_{0,\nu} + \sum_{j=1}^p \sum_{\nu=1}^{\infty} (1-\nu)\alpha_{j,\nu}, \\ \Lambda_{j,k}^0 &:= \Lambda_{j,0} - \Lambda_{k,0} = \sum_{\nu=1}^{\infty} \nu(\alpha_{k,\nu} - \alpha_{j,\nu}) \quad (0 \leq j < k \leq p), \\ \Lambda(\lambda) &:= -\Lambda_0 - \sum_{j=0}^p \sum_{\nu=1}^{\infty} \left( \sum_{i=1}^{\nu} \lambda_{j,i} \right) \alpha_{j,\nu} \\ &= -\Lambda_0 + \sum_{j=0}^p \sum_{\nu=1}^{\infty} \lambda_{j,\nu} (\Lambda_{j,\nu-1} - \Lambda_{j,\nu}). \end{aligned}$$

Under the above definition we have

$$(9.19) \quad (\Lambda^0 | \alpha) = (\Lambda_{j,k}^0 | \alpha) = 0 \quad (\forall \alpha \in \Pi_p),$$

$$(9.20) \quad (\Lambda_{j,\nu} | \alpha_{j',\nu'}) = \delta_{j,j'} \delta_{\nu,\nu'} \quad (j, j' = 0, 1, \dots, \nu, \nu' = 1, 2, \dots)$$

$$(9.21) \quad (\Lambda_0 | \alpha_i) = (\Lambda_{j,0} | \alpha_i) = \delta_{i,0} \quad (\forall i \in \Pi_p),$$

$$(9.22) \quad |\{\lambda_{\mathbf{m}}\}| = (\Lambda(\lambda) + \frac{1}{2}\alpha_{\mathbf{m}} | \alpha_{\mathbf{m}}),$$

$$\begin{aligned}
(9.23) \quad s_0(\Lambda(\lambda)) &= -\left(\sum_{j=0}^p \lambda_{j,1} - 1\right)\alpha_0 + \Lambda(\lambda) \\
&= -\mu\Lambda^0 - \Lambda_0 - \sum_{\nu=1}^{\infty} \left(\sum_{i=1}^{\nu} (\lambda_{0,i} - (1 + \delta_{i,0})\mu)\right)\alpha_{0,\nu} \\
&\quad - \sum_{j=1}^p \sum_{\nu=1}^{\infty} \left(\sum_{i=1}^{\nu} (\lambda_{j,i} + (1 - \delta_{i,0})\mu)\right)\alpha_{j,\nu}
\end{aligned}$$

with  $\mu = \sum_{j=0}^p \lambda_{j,1} - 1$ .

We identify the elements of  $\mathfrak{h}_p^\vee$  if their difference are in  $\mathbb{C}\Lambda^0$ , namely, consider them in  $\bar{\mathfrak{h}}_p := \mathfrak{h}_p^\vee / \mathbb{C}\Lambda^0$ . Then the elements have the unique representatives in  $\mathfrak{h}_p^\vee$  whose coefficients of  $\alpha_0$  equal  $-\frac{1}{2}$ .

*Remark 9.4.* i) If  $p < \infty$ , we have

$$(9.24) \quad \{\Lambda \in \mathfrak{h}_p^\vee; (\Lambda|\alpha) = 0 \quad (\forall \alpha \in \Pi_p)\} = \mathbb{C}\Lambda^0 + \sum_{j=1}^p \mathbb{C}\Lambda_{0,j}^0.$$

ii) The invariance of the bilinear form  $(\cdot | \cdot)$  under the Weyl group  $W_\infty$  proves (7.15).

iii) The addition given in Theorem 7.2 i) corresponds to the map  $\Lambda(\lambda) \mapsto \Lambda(\lambda) + \tau\Lambda_{0,j}^0$  with  $\tau \in \mathbb{C}$  and  $1 \leq j \leq p$ .

iii) Combining the action of  $s_{j,\nu}$  on  $\mathfrak{h}_p^\vee$  with that of  $s_0$ , we have

$$(9.25) \quad \Lambda(\lambda') - s_{\alpha_\ell}\Lambda(\lambda) \in \mathbb{C}\Lambda^0 \quad \text{and} \quad \alpha_{\mathbf{m}'} = s_{\alpha_\ell}\alpha_{\mathbf{m}} \quad \text{when} \quad \{\lambda'_{\mathbf{m}'}\} = \partial_\ell\{\lambda_{\mathbf{m}}\}$$

because of (7.29) and (9.23).

Thus we have the following theorem.

**Theorem 9.5.** *Under the above notation we have the commutative diagram*

$$\begin{array}{ccc}
\{P_{\mathbf{m}} : \text{Fuchsian differential operators with } \{\lambda_{\mathbf{m}}\}\} & \rightarrow & \{(\Lambda(\lambda), \alpha_{\mathbf{m}}); \alpha_{\mathbf{m}} \in \bar{\Delta}_+\} \\
\downarrow \text{fractional operations} & \circlearrowleft & \downarrow W_\infty\text{-action, } +\tau\Lambda_{0,j}^0
\end{array}$$

$$\{P_{\mathbf{m}} : \text{Fuchsian differential operators with } \{\lambda_{\mathbf{m}}\}\} \rightarrow \{(\Lambda(\lambda), \alpha_{\mathbf{m}}); \alpha_{\mathbf{m}} \in \bar{\Delta}_+\}.$$

Here the defining domain of  $w \in W_\infty$  is  $\{\alpha \in \bar{\Delta}_+; w\alpha \in \bar{\Delta}_+\}$ .

*Proof.* Let  $T_i$  denote the corresponding operation on  $\{(P_{\mathbf{m}}, \{\lambda_{\mathbf{m}}\})\}$  for  $s_i \in W_\infty$  with  $i \in I$ . Then  $T_0$  corresponds to  $\partial_1$  and when  $i \in I'$ ,  $T_i$  is naturally defined and it doesn't change  $P_{\mathbf{m}}$ . The fractional transformation of the Fuchsian operators and their Riemann schemes corresponding to an element  $w \in W_\infty$  is defined through the expression of  $w$  by the product of simple reflections. It is clear that the transformation of their Riemann schemes do not depend on the expression.

Let  $i \in I$  and  $j \in I$ . We want to prove that  $(T_i T_j)^k = id$  if  $(s_i s_j)^k = id$  for a non-negative integer  $k$ . Note that  $T_i^2 = id$  and the addition commutes with  $T_i$ . Since  $T_i = id$  if  $i \in I'$ , we have only to prove that  $(T_{j,1} T_0)^3 = id$ . Moreover Proposition 7.7 assures that we may assume  $j = 0$ .

Let  $P$  be a Fuchsian differential operator with the Riemann scheme (6.15). Applying suitable additions to  $P$ , we may assume  $\lambda_{j,1} = 0$  for  $j \geq 1$  to prove  $(T_{0,1} T_0)^3 P = P$  and then this easily follows from the definition of  $\partial_1$  (cf. (7.25))

and the relation

$$\begin{aligned} & \left\{ \begin{array}{cc} \infty & c_j \ (1 \leq j \leq p) \\ [\lambda_{0,1}]_{(m_{0,1})} & [0]_{(m_{j,1})} \\ [\lambda_{0,2}]_{(m_{0,2})} & [\lambda_{j,2}]_{(m_{j,2})} \\ [\lambda_{0,\nu}]_{(m_{0,\nu})} & [\lambda_{j,\nu}]_{(m_{j,\nu})} \end{array} \right\} \quad (d = m_{0,1} + \cdots + m_{p,1} - \text{ord } \mathbf{m}) \\ & \xrightarrow{\frac{T_{0,1}T_0}{\partial^{1-\lambda_{0,1}}}} \left\{ \begin{array}{cc} \infty & c_j \ (1 \leq j \leq p) \\ [\lambda_{0,2} - \lambda_{0,1} + 1]_{(m_{0,1})} & [0]_{(m_{j,1}-d)} \\ [-\lambda_{0,1} + 2]_{(m_{0,2}-d)} & [\lambda_{j,2} + \lambda_{0,1} - 1]_{(m_{j,2})} \\ [\lambda_{0,\nu} - \lambda_{0,1} + 1]_{(m_{0,\nu})} & [\lambda_{j,\nu} + \lambda_{0,1} - 1]_{(m_{j,\nu})} \end{array} \right\} \\ & \xrightarrow{\frac{T_{0,1}T_0}{\partial^{\lambda_{0,1}-\lambda_{0,2}}}} \left\{ \begin{array}{cc} \infty & c_j \ (1 \leq j \leq p) \\ [-\lambda_{0,2} + 2]_{(m_{0,1}-d)} & [0]_{(m_{j,1}+m_{0,1}-m_{0,2}-d)} \\ [\lambda_{0,1} - \lambda_{0,2} + 1]_{(m_{0,1})} & [\lambda_{j,2} + \lambda_{0,2} - 1]_{(m_{j,2})} \\ [\lambda_{0,\nu} - \lambda_{0,2} + 1]_{(m_{0,\nu})} & [\lambda_{j,\nu} + \lambda_{0,2} - 1]_{(m_{j,\nu})} \end{array} \right\} \\ & \xrightarrow{\frac{T_{0,1}T_0}{\partial^{\lambda_{0,2}-1}}} \left\{ \begin{array}{cc} \infty & c_j \ (1 \leq j \leq p) \\ [\lambda_{0,1}]_{(m_{0,1})} & [0]_{(m_{j,1})} \\ [\lambda_{0,2}]_{(m_{0,2})} & [\lambda_{j,2}]_{(m_{j,2})} \\ [\lambda_{0,\nu}]_{(m_{0,\nu})} & [\lambda_{j,\nu}]_{(m_{j,\nu})} \end{array} \right\} \end{aligned}$$

and  $(T_{0,1}T_0)^3 P \in \mathbb{C}[x] \text{Ad}(\partial^{\lambda_{0,2}-1}) \circ \text{Ad}(\partial^{\lambda_{0,2}-\lambda_{0,1}}) \circ \text{Ad}(\partial^{1-\lambda_{0,1}}) \text{R}P = \mathbb{C}[x] \text{R}P$ .  $\square$

**Definition 9.6.** For an element  $w$  of the Weyl group  $W_\infty$  we put

$$(9.26) \quad \Delta(w) := \Delta_+^{re} \cap w^{-1} \Delta_-^{re}.$$

If  $w = s_{i_1} s_{i_2} \cdots s_{i_k}$  with  $i_\nu \in I$  is the *minimal expression* of  $w$  as the products of simple reflections which means  $k$  is minimal by definition, we have

$$(9.27) \quad \Delta(w) = \{\alpha_{i_k}, s_{i_k}(\alpha_{i_{k-1}}), s_{i_k} s_{i_{k-1}}(\alpha_{i_{k-2}}), \dots, s_{i_k} \cdots s_{i_2}(\alpha_{i_1})\}.$$

The number of the elements of  $\Delta(w)$  equals the number of the simple reflections in the minimal expression of  $w$ , which is called the *length* of  $w$  and denoted by  $L(w)$ . The equality (9.27) follows from the following lemma.

**Lemma 9.7.** Fix  $w \in W_\infty$  and  $i \in I$ . If  $\alpha_i \in \Delta(w)$ , there exists a minimal expression  $w = s_{i'_1} s_{i'_2} \cdots s_{i'_k}$  with  $s_{i'_k} = s_i$  and  $L(ws_i) = L(w) - 1$  and  $\Delta(ws_i) = s_i(\Delta(w) \setminus \{\alpha_i\})$ . If  $\alpha_i \notin \Delta(w)$ ,  $L(ws_i) = L(w) + 1$  and  $\Delta(ws_i) = s_i \Delta(w) \cup \{\alpha_i\}$ . Moreover if  $v \in W_\infty$  satisfies  $\Delta(v) = \Delta(w)$ , then  $v = w$ .

*Proof.* The proof is standard as in the case of classical root system, which follows from the fact that the condition  $\alpha_i = s_{i_k} \cdots s_{i_{\ell+1}}(\alpha_{i_\ell})$  implies

$$(9.28) \quad s_i = s_{i_k} \cdots s_{i_{\ell+1}} s_{i_\ell} s_{i_{\ell+1}} \cdots s_{i_k}$$

and then  $w = ws_i s_i = s_{i_1} \cdots s_{i_{\ell-1}} s_{i_{\ell+1}} \cdots s_{i_k} s_i$ .  $\square$

**Definition 9.8.** For  $\alpha \in Q$ , put

$$(9.29) \quad h(\alpha) := n_0 + \sum_{j \geq 0} \sum_{\nu \geq 1} n_{j,\nu} \quad \text{if } \alpha = n_0 \alpha_0 + \sum_{j \geq 0} \sum_{\nu \geq 1} n_{j,\nu} \alpha_{j,\nu} \in Q.$$

Suppose  $\mathbf{m} \in \mathcal{P}_{p+1}$  is irreducibly realizable. Note that  $sf\mathbf{m}$  is the monotone fundamental element determined by  $\mathbf{m}$ , namely,  $\alpha_{sf\mathbf{m}}$  is the unique element of  $W\alpha_{\mathbf{m}} \cap (B \cup \{\alpha_0\})$ . We inductively define  $w_{\mathbf{m}} \in W_\infty$  satisfying  $w_{\mathbf{m}} \alpha_{\mathbf{m}} = \alpha_{sf\mathbf{m}}$ . We may assume  $w_{\mathbf{m}'}$  has already defined if  $h(\alpha_{\mathbf{m}'}) < h(\alpha_{\mathbf{m}})$ . If  $\mathbf{m}$  is not monotone, there exists  $i \in I \setminus \{0\}$  such that  $(\alpha_{\mathbf{m}}|\alpha_i) > 0$  and then  $w_{\mathbf{m}} = w_{\mathbf{m}'} s_i$  with  $\alpha_{\mathbf{m}'} = s_i \alpha_{\mathbf{m}}$ . If  $\mathbf{m}$  is monotone and  $\mathbf{m} \neq f\mathbf{m}$ ,  $w_{\mathbf{m}} = w_{\partial\mathbf{m}} s_0$ .

We moreover define

$$(9.30) \quad \Delta(\mathbf{m}) := \Delta(w_{\mathbf{m}}).$$

Suppose  $\mathbf{m}$  is monotone, irreducibly realizable and  $\mathbf{m} \neq sf\mathbf{m}$ . We define  $w_{\mathbf{m}}$  so that there exists  $K \in \mathbb{Z}_{>0}$  and  $v_1, \dots, v_K \in W'_\infty$  satisfying

$$(9.31) \quad \begin{aligned} w_{\mathbf{m}} &= v_K s_0 \cdots v_2 s_0 v_1 s_0, \\ (v_k s_0 \cdots v_1 s_0 \alpha_{\mathbf{m}} | \alpha) &\leq 0 \quad (\forall \alpha \in \Pi \setminus \{0\}, k = 1, \dots, K), \end{aligned}$$

which uniquely characterizes  $w_{\mathbf{m}}$ . Note that

$$(9.32) \quad v_k s_0 \cdots v_1 s_0 \alpha_{\mathbf{m}} = \alpha_{(s\partial)^k \mathbf{m}} \quad (k = 1, \dots, K).$$

The following proposition gives the correspondence between the reduction of realizable tuples of partitions and the minimal expressions of the elements of the Weyl group.

**Proposition 9.9.** *Definition 9.8 naturally gives the product expression  $w_{\mathbf{m}} = s_{i_1} \cdots s_{i_k}$  with  $i_\nu \in I$  ( $1 \leq \nu \leq k$ ).*

i) *We have*

$$(9.33) \quad L(w_{\mathbf{m}}) = k,$$

$$(9.34) \quad (\alpha | \alpha_{\mathbf{m}}) > 0 \quad (\forall \alpha \in \Delta(\mathbf{m})),$$

$$(9.35) \quad h(\alpha_{\mathbf{m}}) = h(\alpha_{sf\mathbf{m}}) + \sum_{\alpha \in \Delta(\mathbf{m})} (\alpha | \alpha_{\mathbf{m}}).$$

Moreover  $\alpha_0 \in \text{supp } \alpha$  for  $\alpha \in \Delta(\mathbf{m})$  if  $\mathbf{m}$  is monotone.

ii) *Suppose  $\mathbf{m}$  is monotone and  $f\mathbf{m} \neq \mathbf{m}$ . Fix maximal integers  $\nu_j$  such that  $m_{j,1} - d_{\max}(\mathbf{m}) < m_{j,\nu_j+1}$  for  $j = 0, 1, \dots$ . Then*

$$(9.36) \quad \begin{aligned} \Delta(\mathbf{m}) &= s_0 \left( \prod_{\substack{j \geq 0 \\ \nu_j > 0}} s_{j,1} \cdots s_{j,\nu_j} \right) \Delta(s\partial\mathbf{m}) \cup \{\alpha_0\} \\ &\cup \{\alpha_0 + \alpha_{j,1} + \cdots + \alpha_{j,\nu_j}; 1 \leq \nu \leq \nu_j \text{ and } j = 0, 1, \dots\}, \end{aligned}$$

$$(9.37) \quad (\alpha_0 + \alpha_{j,1} + \cdots + \alpha_{j,\nu} | \alpha_{\mathbf{m}}) = d_{\max}(\mathbf{m}) + m_{j,\nu+1} - m_{j,1} \quad (\nu \geq 0).$$

iii) *Suppose  $\mathbf{m}$  is not rigid. Then  $\Delta(\mathbf{m}) = \{\alpha \in \Delta_+^{re}; (\alpha | \alpha_{\mathbf{m}}) > 0\}$ .*

iv) *Suppose  $\mathbf{m}$  is rigid. Let  $\alpha \in \Delta_+^{re}$  satisfying  $(\alpha | \alpha_{\mathbf{m}}) > 0$  and  $s_\alpha(\alpha_{\mathbf{m}}) \in \Delta_+$ . Then*

$$(9.38) \quad \begin{cases} \alpha \in \Delta(\mathbf{m}) & \text{if } (\alpha | \alpha_{\mathbf{m}}) > 1, \\ \#\left(\{\alpha, \alpha_{\mathbf{m}} - \alpha\} \cap \Delta(\mathbf{m})\right) = 1 & \text{if } (\alpha | \alpha_{\mathbf{m}}) = 1. \end{cases}$$

Moreover if a root  $\gamma \in \Delta(\mathbf{m})$  satisfies  $(\gamma | \alpha_{\mathbf{m}}) = 1$ , then  $\alpha_{\mathbf{m}} - \gamma \in \Delta_+^{re}$  and  $\alpha_0 \in \text{supp}(\alpha_{\mathbf{m}} - \gamma)$ .

v)  $w_{\mathbf{m}}$  is the unique element with the minimal length satisfying  $w_{\mathbf{m}} \alpha_{\mathbf{m}} = \alpha_{sf\mathbf{m}}$ .

*Proof.* Since  $h(s_{i'}\alpha) - h(\alpha) = -(\alpha_{i'} | \alpha) = (s_{i'}\alpha_{i'} | \alpha)$ , we have

$$\begin{aligned} h(s_{i'_\ell} \cdots s_{i'_1} \alpha) - h(\alpha) &= \sum_{\nu=1}^{\ell} \left( h(s_{i'_\nu} \cdots s_{i'_1} \alpha) - h(s_{i'_{\nu-1}} \cdots s_{i'_1} \alpha) \right) \\ &= \sum_{\nu=1}^{\ell} (\alpha_{i'_\nu} | s_{i'_\nu} \cdots s_{i'_1} \alpha) = \sum_{\nu=1}^{\ell} (s_{i'_\ell} \cdots s_{i'_{\nu+1}} \alpha_{i'_\nu} | s_{i'_\ell} \cdots s_{i'_1} \alpha) \end{aligned}$$

for  $i', i'_\nu \in I$  and  $\alpha \in \Delta$ .

i) We show by the induction on  $k$ . We may assume  $k \geq 1$ . Put  $w' = s_{i_1} \cdots s_{i_{k-1}}$  and  $\alpha_{\mathbf{m}'} = s_{i_k} \alpha_{\mathbf{m}}$  and  $\alpha(\nu) = s_{i_{k-1}} \cdots s_{i_{\nu+1}} \alpha_{i_\nu}$  for  $\nu = 1, \dots, k-1$ . The hypothesis of the induction assures  $L(w') = k-1$ ,  $\Delta(\mathbf{m}') = \{\alpha(1), \dots, \alpha(k-1)\}$

and  $(\alpha(\nu)|\alpha_{\mathbf{m}'}) > 0$  for  $\nu = 1, \dots, k-1$ . If  $L(w_{\mathbf{m}}) \neq k$ , there exists  $\ell$  such that  $\alpha_{i_k} = \alpha(\ell)$  and  $w_{\mathbf{m}} = s_{i_1} \cdots s_{i_{\ell-1}} s_{i_{\ell+1}} \cdots s_{i_{k-1}}$  is a minimal expression. Then  $h(\alpha_{\mathbf{m}}) - h(\alpha_{\mathbf{m}'}) = -(\alpha_{i_k}|\alpha_{\mathbf{m}'}) = -(\alpha(\ell)|\alpha_{\mathbf{m}'}) < 0$ , which contradicts to the definition of  $w_{\mathbf{m}}$ . Hence we have i). Note that (9.34) implies  $\text{supp } \alpha \ni \alpha_0$  if  $\alpha \in \Delta(\mathbf{m})$  and  $\mathbf{m}$  is monotone.

ii) The equality (9.36) follows from

$$\Delta(\partial\mathbf{m}) \cap \sum_{\alpha \in \Pi \setminus \{0\}} \mathbb{Z}\alpha = \{\alpha_{j,1} + \cdots + \alpha_{j,\nu_j}; \nu = 1, \dots, \nu_j, \nu_j > 0 \text{ and } j = 0, 1, \dots\}$$

because  $\Delta(\mathbf{m}) = s_0\Delta(\partial\mathbf{m}) \cup \{\alpha_0\}$  and  $(\prod_{\substack{j \geq 0 \\ \nu_j > 0}} s_{j,\nu_j} \cdots s_{j,1})\alpha_{\partial\mathbf{m}} = \alpha_{s\partial\mathbf{m}}$ .

The equality (9.37) is clear because  $(\alpha_0|\alpha_{\mathbf{m}}) = d_{\mathbf{1}}(\mathbf{m}) = d_{\max}(\mathbf{m})$  and  $(\alpha_{j,\nu}|\alpha_{\mathbf{m}}) = m_{j,\nu+1} - m_{j,\nu}$ .

iii) Note that  $\gamma \in \Delta(\mathbf{m})$  satisfies  $(\gamma|\alpha_{\mathbf{m}}) > 0$ .

Put  $w_{\nu} = s_{i_{\nu+1}} \cdots s_{i_{k-1}} s_{i_k}$  for  $\nu = 0, \dots, k$ . Then  $w_{\mathbf{m}} = w_0$  and  $\Delta(\mathbf{m}) = \{w_{\nu}^{-1}\alpha_{i_{\nu}}; \nu = 1, \dots, k\}$ . Moreover  $w_{\nu'}w_{\nu}^{-1}\alpha_{i_{\nu}} \in \Delta_{+}^{re}$  if and only if  $0 \leq \nu' < \nu$ .

Suppose  $\mathbf{m}$  is not rigid. Let  $\alpha \in \Delta_{+}^{re}$  with  $(\alpha|\alpha_{\mathbf{m}}) > 0$ . Since  $(w_{\mathbf{m}}\alpha|\alpha_{\overline{\mathbf{m}}}) > 0$ ,  $w_{\mathbf{m}}\alpha \in \Delta_{-}^{re}$ . Hence there exists  $\nu$  such that  $w_{\nu}\alpha \in \Delta_{+}$  and  $w_{\nu-1}\alpha \in \Delta_{-}$ , which implies  $w_{\nu}\alpha = \alpha_{i_{\nu}}$  and the claim.

iv) Suppose  $\mathbf{m}$  is rigid. Let  $\alpha \in \Delta_{+}^{re}$ . Put  $\ell = (\alpha|\alpha_{\mathbf{m}})$ . Suppose  $\ell > 0$  and  $\beta := s_{\alpha}\alpha_{\mathbf{m}} \in \Delta_{+}$ . Then  $\alpha_{\mathbf{m}} = \ell\alpha + \beta$ ,  $\alpha_0 = \ell w_{\mathbf{m}}\alpha + w_{\mathbf{m}}\beta$  and  $(\beta|\alpha_{\mathbf{m}}) = (\alpha_{\mathbf{m}} - \ell\alpha|\alpha_{\mathbf{m}}) = 2 - \ell^2$ . Hence if  $\ell \geq 2$ ,  $\mathbb{R}\beta \cap \Delta(\mathbf{m}) = \emptyset$  and the same argument as in the proof of iii) assures  $\alpha \in \Delta(\mathbf{m})$ .

Suppose  $\ell = 1$ . There exists  $\nu$  such that  $w_{\nu}\alpha$  or  $w_{\nu}\beta$  equals  $\alpha_{i_{\nu}}$ . We may assume  $w_{\nu}^{-1}\alpha = \alpha_{i_{\nu}}$ . Then  $\alpha \in \Delta(\mathbf{m})$ .

Suppose there exists  $w_{\nu'}\beta = \alpha_{i_{\nu'}}$ . We may assume  $\nu' < \nu$ . Then  $w_{\nu'}\alpha_{\mathbf{m}} = w_{\nu'-1}\alpha + w_{\nu'-1}\beta \in \Delta_{-}^{re}$ , which contradicts to the definition of  $w_{\nu}$ . Hence  $w_{\nu'}\beta = \alpha_{i_{\nu'}}$  for  $\nu' = 1, \dots, k$  and therefore  $\beta \notin \Delta(\mathbf{m})$ .

Let  $\gamma = w_{\nu}^{-1}\alpha_{i_{\nu}} \in \Delta(\mathbf{m})$  and  $(\gamma|\alpha_{\mathbf{m}}) = 1$ . Put  $\beta = \alpha_{\mathbf{m}} - \alpha = s_{\alpha}\alpha_{\mathbf{m}}$ . Then  $w_{\nu-1}\alpha_{\mathbf{m}} = w_{\nu}\beta \in \Delta_{+}^{re}$ . Since  $\beta \notin \Delta(\mathbf{m})$ , we have  $\beta \in \Delta_{+}^{re}$ .

Replacing  $\mathbf{m}$  by  $s\mathbf{m}$ , we may assume  $\mathbf{m}$  is monotone to prove  $\alpha_0 \in \text{supp } \beta$ . Since  $(\beta|\alpha_{\mathbf{m}}) = 1$  and  $(\alpha_i|\alpha_{\mathbf{m}}) \leq 0$  for  $i \in I \setminus \{0\}$ , we have  $\alpha_0 \in \text{supp } \beta$ .

v) The uniqueness of  $w_{\mathbf{m}}$  follows from iii) when  $\mathbf{m}$  is not rigid. It follows from (9.34), Theorem 17.1 and Corollary 17.3 when  $\mathbf{m}$  is rigid.  $\square$

**Corollary 9.10.** *Let  $\mathbf{m}, \mathbf{m}', \mathbf{m}'' \in \mathcal{P}$  and  $k \in \mathbb{Z}_{>0}$  such that*

$$(9.39) \quad \mathbf{m} = k\mathbf{m}' + \mathbf{m}'', \text{ idx } \mathbf{m} = \text{idx } \mathbf{m}'' \text{ and } \mathbf{m}' \text{ is rigid.}$$

*Then  $\mathbf{m}$  is irreducibly realizable if and only if so is  $\mathbf{m}''$ .*

*Suppose  $\mathbf{m}$  is irreducibly realizable. If  $\text{idx } \mathbf{m} \leq 0$  or  $k > 1$ , then  $\mathbf{m}' \in \Delta(\mathbf{m})$ . If  $\text{idx } \mathbf{m} = 2$ , then  $\{\alpha_{\mathbf{m}'}, \alpha_{\mathbf{m}''}\} \cap \Delta(\mathbf{m}) = \{\alpha_{\mathbf{m}'}\}$  or  $\{\alpha_{\mathbf{m}''}\}$ .*

*Proof.* The assumption implies  $(\alpha_{\mathbf{m}}|\alpha_{\mathbf{m}}) = 2k^2 + 2k(\alpha_{\mathbf{m}'}|\alpha_{\mathbf{m}''}) + (\alpha_{\mathbf{m}''}|\alpha_{\mathbf{m}''})$  and hence  $(\alpha_{\mathbf{m}'}|\alpha_{\mathbf{m}''}) = -k$  and  $s_{\alpha_{\mathbf{m}'}}\alpha_{\mathbf{m}''} = \alpha_{\mathbf{m}}$ . Thus we have the first claim (cf. Theorem 9.5). The remaining claims follow from Proposition 9.9.  $\square$

**Remark 9.11.** i) In general  $\gamma \in \Delta(\mathbf{m})$  does not always imply  $s_{\gamma}\alpha_{\mathbf{m}} \in \Delta_{+}$ .

Put  $\mathbf{m} = 32, 32, 32, 32$ ,  $\mathbf{m}' = 10, 10, 10, 10$  and  $\mathbf{m}'' = 01, 01, 01, 01$ . Putting  $v = s_{0,1}s_{1,1}s_{2,1}s_{3,1}$ , we have  $\alpha_{\mathbf{m}'} = \alpha_0$ ,  $\alpha_{\mathbf{m}''} = v\alpha_0$ ,  $(\alpha_{\mathbf{m}'}|\alpha_{\mathbf{m}''}) = -2$ ,  $s_0\alpha_{\mathbf{m}''} = 2\alpha_{\mathbf{m}'} + \alpha_{\mathbf{m}''}$ ,  $vs_0\alpha_{\mathbf{m}''} = \alpha_0 + 2\alpha_{\mathbf{m}'}$  and  $s_0vs_0v\alpha_0 = s_0vs_0\alpha_{\mathbf{m}''} = 3\alpha_{\mathbf{m}'} + 2\alpha_{\mathbf{m}''} = \alpha_{\mathbf{m}}$ .

Then  $\gamma := s_0v\alpha_0 = 2\alpha_{\mathbf{m}'} + \alpha_{\mathbf{m}''} \in \Delta(\mathbf{m})$ ,  $(\gamma|\alpha_{\mathbf{m}}) = (s_0v\alpha_{\mathbf{m}'}|s_0vs_0v\alpha_{\mathbf{m}'}) = (\alpha_{\mathbf{m}'}|s_0v\alpha_{\mathbf{m}'}) = (\alpha_{\mathbf{m}'}|2\alpha_{\mathbf{m}'} + \alpha_{\mathbf{m}''}) = 2$  and  $s_{\gamma}(\alpha_{\mathbf{m}}) = (3\alpha_{\mathbf{m}'} + 2\alpha_{\mathbf{m}''}) - 2(2\alpha_{\mathbf{m}'} + \alpha_{\mathbf{m}''}) = -\alpha_{\mathbf{m}'} \in \Delta_{-}$ .

ii) Define

$$(9.40) \quad [\Delta(\mathbf{m})] := \{(\alpha|\alpha_{\mathbf{m}}); \alpha \in \Delta(\mathbf{m})\}.$$

Then  $[\Delta(\mathbf{m})]$  gives a partition of the non-negative integer  $h(\alpha_{\mathbf{m}}) - h(sf\mathbf{m})$ , which we call *the type of  $\Delta(\mathbf{m})$* . It follows from (9.35) that

$$(9.41) \quad \#\Delta(\mathbf{m}) \leq h(\alpha_{\mathbf{m}}) - h(sf\mathbf{m})$$

for a realizable tuple  $\mathbf{m}$  and the equality holds in the above if  $\mathbf{m}$  is monotone and simply reducible. Moreover we have

$$(9.42) \quad [\Delta(\mathbf{m})] = [\Delta(sf\mathbf{m})] \cup \{d(\mathbf{m})\} \cup \bigcup_{j=0}^p \{m_{j,\nu} - m_{j,1} - d(\mathbf{m}) \in \mathbb{Z}_{>0}; \nu > 1\},$$

$$(9.43) \quad \#\Delta(\mathbf{m}) = \#\Delta(s\partial\mathbf{m}) + \sum_{j=0}^p \left( \min\{\nu; m_{j,\nu} > m_{j,1} - d(\mathbf{m})\} - 1 \right) + 1$$

if  $\mathbf{m} \in \mathcal{P}_{p+1}$  is monotone, irreducibly realizable and not fundamental. Here we use the notation in Definitions 6.11, 7.6 and 8.14. For example,

type	$\mathbf{m}$	$h(\alpha_{\mathbf{m}})$	$\#\Delta(\mathbf{m})$
$H_n$	$1^n, 1^n, n - 11$	$n^2 + 1$	$n^2$
$EO_{2m}$	$1^{2m}, mm, mm - 11$	$2m^2 + 3m + 1$	$\binom{2m}{2} + 4m$
$EO_{2m+1}$	$1^{2m+1}, m + 1m, mm1$	$2m^2 + 5m + 3$	$\binom{2m+1}{2} + 4m + 2$
$X_6$	111111, 222, 42	29	28
	21111, 222, 33	25	24
$P_n$	$n - 11, n - 11, \dots \in \mathcal{P}_{n+1}^{(n)}$	$2n + 1$	$[\Delta(\mathbf{m})] : 1^{n+1} \cdot (n - 1)$
$P_{4,2m+1}$	$m + 1m, m + 1m, m + 1m, m + 1m$	$6m + 1$	$[\Delta(\mathbf{m})] : 1^{4m} \cdot 2^m$

Suppose  $\mathbf{m} \in \mathcal{P}_{p+1}$  is basic. We may assume (8.3). Suppose  $(\alpha_{\mathbf{m}}|\alpha_0) = 0$ , which is equivalent to  $\sum_{j=0}^p m_{j,1} = (p - 1) \text{ord } \mathbf{m}$ . Let  $k_j$  be positive integers such that

$$(9.44) \quad (\alpha_{\mathbf{m}}|\alpha_{j,\nu}) = 0 \text{ for } 1 \leq \nu < k_j \text{ and } (\alpha_{\mathbf{m}}|\alpha_{j,k_j}) < 0,$$

which is equivalent to  $m_{j,1} = m_{j,2} = \dots = m_{j,k_j} > m_{j,k_j+1}$  for  $j = 0, \dots, p$ . Then

$$(9.45) \quad \sum_{j=0}^p \frac{1}{k_j} \geq \sum_{j=0}^p \frac{m_{j,1}}{\text{ord } \mathbf{m}} = p - 1.$$

If the equality holds in the above, we have  $k_j \geq 2$  and  $m_{j,k_j+1} = 0$  and therefore  $\mathbf{m}$  is of one of the types  $\tilde{D}_4$  or  $\tilde{E}_6$  or  $\tilde{E}_7$  or  $\tilde{E}_8$ . Hence if  $\text{idx } \mathbf{m} < 0$ , the set  $\{k_j; 0 \leq j \leq p, k_j > 1\}$  equals one of the set  $\emptyset, \{2\}, \{2, \nu\}$  with  $2 \leq \nu \leq 5, \{3, \nu\}$  with  $3 \leq \nu \leq 5, \{2, 2, \nu\}$  with  $2 \leq \nu \leq 5$  and  $\{2, 3, \nu\}$  with  $3 \leq \nu \leq 5$ . In this case the corresponding Dynkin diagram of  $\{\alpha_0, \alpha_{j,\nu}; 1 \leq \nu < k_j, j = 0, \dots, p\}$  is one of the types  $A_\nu$  with  $1 \leq \nu \leq 6, D_\nu$  with  $4 \leq \nu \leq 7$  and  $E_\nu$  with  $6 \leq \nu \leq 8$ . Thus we have the following remark.

*Remark 9.12.* Suppose a tuple  $\mathbf{m} \in \mathcal{P}_{p+1}^{(n)}$  is basic and monotone. The subgroup of  $W_\infty$  generated by reflections with respect to  $\alpha_\ell$  (cf. (9.13)) which satisfy  $(\alpha_{\mathbf{m}}|\alpha_\ell) = 0$  is infinite if and only if  $\text{idx } \mathbf{m} = 0$ .

For a realizable monotone tuple  $\mathbf{m} \in \mathcal{P}$ , we define

$$(9.46) \quad \Pi(\mathbf{m}) := \{\alpha_{j,\nu} \in \text{supp } \alpha_{\mathbf{m}}; m_{j,\nu} = m_{j,\nu+1}\} \cup \begin{cases} \{\alpha_0\} & (d_1(\mathbf{m}) = 0), \\ \emptyset & (d_1(\mathbf{m}) \neq 0). \end{cases}$$

Note that the condition  $(\alpha_{\mathbf{m}}|\alpha_\ell) = 0$ , which is equivalent to say that  $\alpha_\ell$  is a root of the root space with the fundamental system  $\Pi(\mathbf{m})$ , means that the corresponding middle convolution  $\partial_\ell$  keeps the spectral type invariant.



**9.2. Fundamental tuples.** We will prove some inequalities (9.47) and (9.48) for fundamental tuples which are announced in [O6].

**Proposition 9.13.** *Let  $\mathbf{m} \in \mathcal{P}_{p+1} \setminus \mathcal{P}_p$  be a fundamental tuple. Then*

$$(9.47) \quad \text{ord } \mathbf{m} \leq 3|\text{idx } \mathbf{m}| + 6,$$

$$(9.48) \quad \text{ord } \mathbf{m} \leq |\text{idx } \mathbf{m}| + 2 \quad \text{if } p \geq 3,$$

$$(9.49) \quad p \leq \frac{1}{2}|\text{idx } \mathbf{m}| + 3.$$

**Example 9.14.** For a positive integer  $m$  we have special 4 elements

$$(9.50) \quad \begin{array}{ll} D_4^{(m)} : m^2, m^2, m^2, m(m-1)1 & E_6^{(m)} : m^3, m^3, m^2(m-1)1 \\ E_7^{(m)} : (2m)^2, m^4, m^3(m-1)1 & E_8^{(m)} : (3m)^2, (2m)^3, m^5(m-1)1 \end{array}$$

with orders  $2m, 3m, 4m$  and  $6m$ , respectively, and index of rigidity  $2 - 2m$ .

Note that  $E_8^{(m)}, D_4^{(m)}$  and  $11, 11, 11, \dots \in \mathcal{P}_{p+1}^{(2)}$  attain the equalities (9.47), (9.48) and (9.49), respectively.

*Remark 9.15.* It follows from the Proposition 9.13 that there exist only finite basic tuples  $\mathbf{m} \in \mathcal{P}$  with a fixed index of rigidity under the normalization (8.3). This result is given in [O6, Proposition 8.1].

Hence there exist only finite *fundamental universal Fuchsian differential operators* with a fixed number of accessory parameters. Here a fundamental universal Fuchsian differential operator means a universal operator given in Theorem 8.13 whose spectral type is fundamental (cf. Definition 8.14).

Now we prepare a lemma.

**Lemma 9.16.** *Let  $a \geq 0, b > 0$  and  $c > 0$  be integers such that  $a + c - b > 0$ . Then*

$$\frac{b + kc - 6}{(a + c - b)b} \begin{cases} < k + 1 & (0 \leq k \leq 5), \\ \leq 7 & (0 \leq k \leq 6). \end{cases}$$

*Proof.* Suppose  $b \geq c$ . Then

$$\frac{b + kc - 6}{(a + c - b)b} \leq \frac{b + kb - 6}{b} < k + 1.$$

Next suppose  $b < c$ . Then

$$\begin{aligned} (k+1)(a+c-b)b - (b+kc-6) &\geq (k+1)(c-b)b - b - kc + 6 \\ &\geq (k+1)b - b - k(b+1) + 6 = 6 - k. \end{aligned}$$

Thus we have the lemma.  $\square$

*Proof of Proposition 9.13.* Since  $\text{idx } k\mathbf{m} = k^2 \text{idx } \mathbf{m}$  for a basic tuple  $\mathbf{m}$  and  $k \in \mathbb{Z}_{>0}$ , we may assume that  $\mathbf{m}$  is basic and  $\text{idx } \mathbf{m} \leq -2$  to prove the proposition.

Fix a basic monotone tuple  $\mathbf{m}$ . Put  $\alpha = \alpha_{\mathbf{m}}$  under the notation (9.12) and  $n = \text{ord } \mathbf{m}$ . Note that

$$(9.51) \quad (\alpha|\alpha) = n(\alpha|\alpha_0) + \sum_{j=0}^p \sum_{\nu=1}^{n_j} n_{j,\nu} (\alpha|\alpha_{j,\nu}), \quad (\alpha|\alpha_0) \leq 0, \quad (\alpha|\alpha_{j,\nu}) \leq 0.$$

We first assume that (9.47) is not valid, namely,

$$(9.52) \quad 3|(\alpha|\alpha)| + 6 < n.$$

In view of (8.18), we have  $(\alpha|\alpha) < 0$  and the assumption implies  $|(\alpha|\alpha_0)| = 0$  because  $|(\alpha|\alpha)| \geq n|(\alpha|\alpha_0)|$ .

Let  $\Pi_0$  be the connected component of  $\{\alpha_i \in \Pi; (\alpha|\alpha_i) = 0 \text{ and } \alpha_i \in \text{supp } \alpha\}$  containing  $\alpha_0$ . Note that  $\text{supp } \alpha$  generates a root system which is neither classical nor affine but  $\Pi_0$  generates a root system of finite type.

Put  $J = \{j; \exists \alpha_{j,\nu} \in \text{supp } \alpha_{\mathbf{m}} \text{ such that } (\alpha|_{\alpha_{j,\nu}}) < 0\} \neq \emptyset$  and for each  $j \in J$  define  $k_j$  with the condition (9.44). Then we note that

$$(\alpha|_{\alpha_{j,\nu}}) = \begin{cases} 0 & (1 \leq \nu < k_j), \\ 2n_{j,k_j} - n_{j,k_j-1} - n_{j,k_j+1} \leq -1 & (\nu = k_j). \end{cases}$$

Applying the above lemma to  $\mathbf{m}$  by putting  $n = b + k_j c$  and  $n_{j,\nu} = b + (k_j - \nu)c$  ( $1 \leq \nu \leq k_j$ ) and  $n_{j,k_j+1} = a$ , we have

$$(9.53) \quad \frac{n-6}{(n_{j,k_j-1} + n_{j,k_j+1} - 2n_{j,k_j})n_{j,k_j}} \begin{cases} < k_j + 1 & (1 \leq k_j \leq 5), \\ \leq 7 & (1 \leq k_j \leq 6). \end{cases}$$

Here  $(\alpha|_{\alpha_{j,k_j}}) = b - c - a \leq -1$  and we have  $|(\alpha|_{\alpha})| \geq |(\alpha|_{\alpha_{j,\nu}})| > \frac{n-6}{k_j+1}$  if  $k_j < 6$  and therefore  $k_j \geq 3$ .

It follows from the condition  $k_j \geq 3$  that  $\mathbf{m} \in \mathcal{P}_3$  because  $\Pi_0$  is of finite type and moreover that  $\Pi_0$  is of exceptional type, namely, of type  $E_6$  or  $E_7$  or  $E_8$  because  $\text{supp } \alpha$  is not of finite type.

Suppose  $\#J \geq 2$ . We may assume  $\{0, 1\} \subset J$  and  $k_0 \leq k_1$ . Since  $\Pi_0$  is of exceptional type and  $\text{supp } \alpha$  is not of finite type, we may assume  $k_0 = 3$  and  $k_1 \leq 5$ . Owing to (9.51) and (9.53), we have

$$\begin{aligned} |(\alpha|_{\alpha})| &\geq n_{0,3}(n_{0,2} + n_{0,4} - 2n_{0,3}) + n_{1,k_1}(n_{1,k_1-1} + n_{1,k_1+1} - 2n_{1,k_1}) \\ &> \frac{n-6}{3+1} + \frac{n-6}{5+1} > \frac{n-6}{3}, \end{aligned}$$

which contradicts to the assumption.

Thus we may assume  $J = \{0\}$ . For  $j = 1$  and 2 let  $n_j$  be the positive integer such that  $\alpha_{j,n_j} \in \text{supp } \alpha$  and  $\alpha_{j,n_j+1} \notin \text{supp } \alpha$ . We may assume  $n_1 \geq n_2$ .

First suppose  $k_0 = 3$ . Then  $(n_1, n_2) = (2, 1)$ ,  $(3, 1)$  or  $(4, 1)$  and the Dynkin diagram of  $\text{supp } \alpha$  with the numbers  $m_{j,\nu}$  is one of the diagrams:

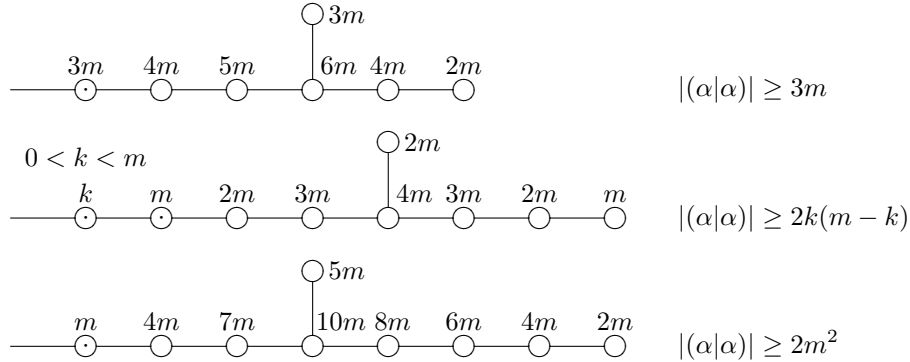

For example, when  $(n_1, n_2) = (3, 1)$ , then  $k := m_{0,4} \geq 1$  because  $(\alpha|_{\alpha_{0,3}}) \neq 0$  and therefore  $0 < k < m$  and  $|(\alpha|_{\alpha})| \geq k(m-2k) + m(2m+k-2m) = 2k(m-k) \geq 2m-2$  and  $3|(\alpha|_{\alpha})| + 6 - 4m \geq 3(2m-2) + 6 - 4m > 0$ . Hence (9.52) doesn't hold.

Other cases don't happen because of the inequalities  $3 \cdot 3m + 6 - 6m > 0$  and  $3 \cdot 2m^2 + 6 - 10m > 0$ .

Lastly suppose  $k_0 > 3$ . Then  $(k_0, n_1, n_2) = (4, 2, 1)$  or  $(5, 2, 1)$ .

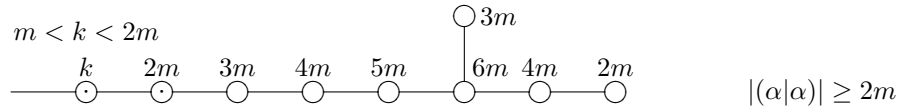

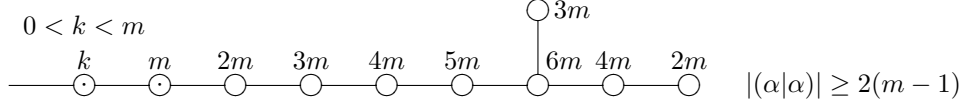

In the above first case we have  $(\alpha|\alpha) \geq 2m$ , which contradicts to (9.52). Note that  $|(\alpha|\alpha)| \geq k \cdot (m-2k) + m \cdot k = 2k(m-k) \geq 2(m-1)$  in the above last case, which also contradicts to (9.52) because  $3 \cdot 2(m-1) + 6 = 6m$ .

Thus we have proved (9.47).

Assume  $\mathbf{m} \notin \mathcal{P}_3$  to prove a different inequality (9.48). In this case, we may assume  $(\alpha|\alpha_0) = 0$ ,  $|(\alpha|\alpha)| \geq 2$  and  $n > 4$ . Note that

$$(9.54) \quad 2n = n_{0,1} + n_{1,1} + \cdots + n_{p,1} \quad \text{with } p \geq 3 \text{ and } n_{j,1} \geq 1 \text{ for } j = 0, \dots, p.$$

If there exists  $j$  with  $1 \leq n_{j,1} \leq \frac{n}{2} - 1$ , (9.48) follows from (9.51) and  $|(\alpha|\alpha_{j,1})| = n_{j,1}(n + n_{j,2} - 2n_{j,1}) \geq 2n_{j,1}(\frac{n}{2} - n_{j,1}) \geq n - 2$ .

Hence we may assume  $n_{j,1} \geq \frac{n-1}{2}$  for  $j = 0, \dots, p$ . Suppose there exists  $j$  with  $n_{j,1} = \frac{n-1}{2}$ . Then  $n$  is odd and (9.54) means that there also exists  $j'$  with  $j \neq j'$  and  $n_{j',1} = \frac{n-1}{2}$ . In this case we have (9.48) since

$$|(\alpha|\alpha_{j,1})| + |(\alpha|\alpha_{j',1})| = n_{j,1}(n + n_{j,2} - 2n_{j,1}) + n_{j',1}(n + n_{j',2} - 2n_{j',1}) \geq \frac{n-1}{2} + \frac{n-1}{2}.$$

Now we may assume  $n_{j,1} \geq \frac{n}{2}$  for  $j = 0, \dots, p$ . Then (9.54) implies that  $p = 3$  and  $n_{j,1} = \frac{n}{2}$  for  $j = 0, \dots, 3$ . Since  $(\alpha|\alpha) < 0$ , there exists  $j$  with  $n_{j,2} \geq 1$  and

$$\begin{aligned} |(\alpha|\alpha_{j,1})| + |(\alpha|\alpha_{j,2})| &= n_{j,1}(n + n_{j,2} - 2n_{j,1}) + n_{j,2}(n_{j,1} + n_{j,3} - 2n_{j,2}) \\ &= \frac{n}{2}n_{j,2} + n_{j,2}(\frac{n}{2} + n_{j,3} - 2n_{j,2}) \\ &\begin{cases} \geq n & (n_{j,2} \geq 1), \\ = n - 2 & (n_{j,2} = 1 \text{ and } n_{j,3} = 0). \end{cases} \end{aligned}$$

Thus we have completed the proof of (9.48).

There are 4 basic tuples with the index of the rigidity 0 and 13 basic tuples with the index of the rigidity  $-2$ , which are given in (8.18) and Proposition 8.10. They satisfy (9.49).

Suppose that (9.49) is not valid. We may assume that  $p$  is minimal under this assumption. Then  $\text{idx } \mathbf{m} < -2$ ,  $p \geq 5$  and  $n = \text{ord } \mathbf{m} > 2$ . We may assume  $n > n_{0,1} \geq n_{1,1} \geq \cdots \geq n_{p,1} > 0$ . Since  $(\alpha|\alpha_0) \leq 0$ , we have

$$(9.55) \quad n_{0,1} + n_{1,1} + \cdots + n_{p,1} \geq 2n > n_{0,1} + \cdots + n_{p-1,1}.$$

In fact, if  $n_{0,1} + \cdots + n_{p-1,1} \geq 2n$ , the tuple  $\mathbf{m}' = (\mathbf{m}_0, \dots, \mathbf{m}_{p-1})$  is also basic and  $|(\alpha|\alpha)| - |(\alpha_{\mathbf{m}'}, \alpha_{\mathbf{m}'})| = n^2 - \sum_{\nu \geq 1} n_{p,\nu}^2 \geq 2$ , which contradicts to the minimality.

Thus we have  $2n_{j,1} < n$  for  $j = 3, \dots, p$ . If  $n$  is even,  $|\text{idx } \mathbf{m}| \geq \sum_{j=3}^p |(\alpha|\alpha_{j,1})| = \sum_{j=3}^p (n + n_{j,2} - 2n_{j,1}) \geq 2(p-2)$ , which contradicts to the assumption. If  $n = 3$ , (9.55) assures  $p = 5$  and  $n_{0,1} = \cdots = n_{5,0} = 1$  and therefore  $\text{idx } \mathbf{m} = -4$ , which also contradicts to the assumption. Thus  $n = 2m + 1$  with  $m \geq 2$ . Choose  $k$  so that  $n_{k-1,1} \geq m > n_{k,1}$ . Then  $|\text{idx } \mathbf{m}| \geq \sum_{j=k}^p |(\alpha|\alpha_{j,1})| = \sum_{j=k}^p (n + n_{j,2} - 2n_{j,1}) \geq 3(p-k+1)$ . Owing to (9.55), we have  $2(2m+1) > km + (p-k)$  and  $k < \frac{4m+2-p}{m-1} \leq \frac{4m-3}{m-1} \leq 5$ , which means  $k \leq 4$ ,  $|\text{idx } \mathbf{m}| \geq 3(p-3) \geq 2p-4$  and a contradiction to the assumption.  $\square$

## 10. EXPRESSION OF LOCAL SOLUTIONS

Fix  $\mathbf{m} = (m_{j,\nu})_{\substack{j=0,\dots,p \\ 1 \leq \nu \leq n_j}} \in \mathcal{P}_{p+1}$ . Suppose  $\mathbf{m}$  is monotone and irreducibly realizable. Let  $P_{\mathbf{m}}$  be the universal operator with the Riemann scheme (6.15), which is given in Theorem 8.13. Suppose  $c_1 = 0$  and  $m_{1,n_1} = 1$ . We give expressions of the

local solution of  $P_{\mathbf{m}}u = 0$  at  $x = 0$  corresponding to the characteristic exponent  $\lambda_{1,n_1}$ .

**Theorem 10.1.** *Retain the notation above and in Definition 7.11. Suppose  $\lambda_{j,\nu}$  are generic. Let*

$$(10.1) \quad v(x) = \sum_{\nu=0}^{\infty} C_{\nu} x^{\lambda(K)_{1,n_1} + \nu}$$

be the local solution of  $(\partial_{\max}^K P_{\mathbf{m}})v = 0$  at  $x = 0$  with the condition  $C_0 = 1$ . Put

$$(10.2) \quad \lambda(k)_{j,max} = \lambda(k)_{j,\ell(k)_j}.$$

Note that if  $\mathbf{m}$  is rigid, then

$$(10.3) \quad v(x) = x^{\lambda(K)_{1,n_1}} \prod_{j=2}^p \left(1 - \frac{x}{c_j}\right)^{\lambda(K)_{j,max}}.$$

The function

$$(10.4) \quad \begin{aligned} u(x) := & \prod_{k=0}^{K-1} \frac{\Gamma(\lambda(k)_{1,n_1} - \lambda(k)_{1,max} + 1)}{\Gamma(\lambda(k)_{1,n_1} - \lambda(k)_{1,max} + \mu(k) + 1) \Gamma(-\mu(k))} \\ & \int_0^{s_0} \cdots \int_0^{s_{K-1}} \prod_{k=0}^{K-1} (s_k - s_{k+1})^{-\mu(k)-1} \\ & \cdot \prod_{k=0}^{K-1} \left( \left( \frac{s_k}{s_{k+1}} \right)^{\lambda(k)_{1,max}} \prod_{j=2}^p \left( \frac{1 - c_j^{-1} s_k}{1 - c_j^{-1} s_{k+1}} \right)^{\lambda(k)_{j,max}} \right) \\ & \cdot v(s_K) ds_K \cdots ds_1 \Big|_{s_0=x} \end{aligned}$$

is the solution of  $P_{\mathbf{m}}u = 0$  so normalized that  $u(x) \equiv x^{\lambda_{1,n_1}} \pmod{x^{\lambda_{1,n_1}+1} \mathcal{O}_0}$ .

Here we note that

$$(10.5) \quad \begin{aligned} & \prod_{k=0}^{K-1} \left( \left( \frac{s_k}{s_{k+1}} \right)^{\lambda(k)_{1,max}} \prod_{j=2}^p \left( \frac{1 - c_j^{-1} s_k}{1 - c_j^{-1} s_{k+1}} \right)^{\lambda(k)_{j,max}} \right) \\ & = \frac{s_0^{\lambda(0)_{1,max}}}{s_K^{\lambda(K-1)_{1,max}}} \prod_{j=1}^p \frac{(1 - c_j^{-1} s_0)^{\lambda(0)_{j,max}}}{(1 - c_j^{-1} s_K)^{\lambda(K-1)_{j,max}}} \\ & \cdot \prod_{k=1}^{K-1} \left( s_k^{\lambda(k)_{1,max} - \lambda(k-1)_{1,max}} \prod_{j=2}^p (1 - c_j^{-1} s_k)^{\lambda(k)_{j,max} - \lambda(k-1)_{j,max}} \right). \end{aligned}$$

When  $\mathbf{m}$  is rigid,

$$(10.6) \quad \begin{aligned} u(x) = & x^{\lambda_{1,n_1}} \left( \prod_{j=2}^p \left(1 - \frac{x}{c_j}\right)^{\lambda(0)_{j,max}} \right) \sum_{\substack{(\nu_{j,k}) \\ 1 \leq k \leq K \\ 2 \leq j \leq p \\ \in \mathbb{Z}_{\geq 0}^{(p-1)K}}} \\ & \prod_{i=0}^{K-1} \frac{(\lambda(i)_{1,n_1} - \lambda(i)_{1,max} + 1)_{\sum_{s=2}^p \sum_{t=i+1}^K \nu_{s,t}}}{(\lambda(i)_{1,n_1} - \lambda(i)_{1,max} + \mu(i) + 1)_{\sum_{s=2}^p \sum_{t=i+1}^K \nu_{s,t}}} \\ & \cdot \prod_{i=1}^K \prod_{s=2}^p \frac{(\lambda(i-1)_{s,max} - \lambda(i)_{s,max})_{\nu_{s,i}}}{\nu_{s,i}!} \cdot \prod_{s=2}^p \left( \frac{x}{c_s} \right)^{\sum_{i=1}^K \nu_{s,i}}. \end{aligned}$$

When  $\mathbf{m}$  is not rigid

$$\begin{aligned}
(10.7) \quad u(x) &= x^{\lambda_{1,n_1}} \left( \prod_{j=2}^p \left(1 - \frac{x}{c_j}\right)^{\lambda^{(0)}_{j,max}} \right) \sum_{\nu_0=0}^{\infty} \sum_{\substack{2 \leq j \leq p \\ 1 \leq k \leq K}} \sum_{\substack{\in \mathbb{Z} \\ \geq 0}}^{(p-1)K} \nu_{s,t} \\
&\prod_{i=0}^{K-1} \frac{(\lambda(i)_{1,n_1} - \lambda(i)_{1,max} + 1)_{\nu_0 + \sum_{s=2}^p \sum_{t=i+1}^K \nu_{s,t}}}{(\lambda(i)_{1,n_1} - \lambda(i)_{1,max} + \mu(i) + 1)_{\nu_0 + \sum_{s=2}^p \sum_{t=i+1}^K \nu_{s,t}}} \\
&\cdot \prod_{s=2}^p \frac{(\lambda(K-1)_{s,max})_{\nu_{s,K}}}{\nu_{s,K}!} \cdot \prod_{i=1}^{K-1} \prod_{s=2}^p \frac{(\lambda(i-1)_{s,max} - \lambda(i)_{s,max})_{\nu_{s,i}}}{\nu_{s,i}!} \\
&\cdot C_{\nu_0} x^{\nu_0} \prod_{s=2}^p \left(\frac{x}{c_s}\right)^{\sum_{i=1}^K \nu_{s,i}}.
\end{aligned}$$

Fix  $j$  and  $k$  and suppose

$$(10.8) \quad \begin{cases} \ell(k-1)_j = \ell(k)_\nu & \text{when } \mathbf{m} \text{ is rigid or } k < K, \\ \ell(k-1)_j = 0 & \text{when } \mathbf{m} \text{ is not rigid and } k = K. \end{cases}$$

Then the terms satisfying  $\nu_{j,k} > 0$  vanish because  $(0)_{\nu_{j,k}} = \delta_{0,\nu_{j,k}}$  for  $\nu_{j,k} = 0, 1, 2, \dots$

*Proof.* The theorem follows from (7.25), (7.26), (7.27), (4.2) and (4.6) by the induction on  $K$ . Note that the integral representation of the normalized solution of  $(\partial_{max} P)v = 0$  corresponding to the exponent  $\lambda(1)_{n_1}$  equals

$$\begin{aligned}
v(x) &:= \prod_{k=1}^{K-1} \frac{\Gamma(\lambda(k)_{1,n_1} - \lambda(k)_{1,max} + 1)}{\Gamma(\lambda(k)_{1,n_1} - \lambda(k)_{1,max} + \mu(k) + 1) \Gamma(-\mu(k))} \\
&\cdot \int_0^{s_1} \cdots \int_0^{s_{K-1}} \prod_{k=0}^{K-1} (s_k - s_{k+1})^{-\mu(k)-1} \\
&\cdot \prod_{k=0}^{K-1} \left( \left(\frac{s_k}{s_{k+1}}\right)^{\lambda^{(k)}_{1,max}} \prod_{j=2}^p \left(\frac{1 - c_j^{-1} s_k}{1 - c_j^{-1} s_{k+1}}\right)^{\lambda^{(k)}_{j,max}} \right) \\
&\cdot v(s_K) ds_K \cdots ds_1 \Big|_{s_1=x} \\
&\equiv x^{\lambda(1)_{1,n_1}} \pmod{x^{\lambda(1)_{1,n_1}+1} \mathcal{O}_0}
\end{aligned}$$

by the induction hypothesis and the normalized solution of  $Pu = 0$  corresponding to the exponent  $\lambda_{1,n_1}$  equals

$$\begin{aligned}
&\frac{\Gamma(\lambda(0)_{1,n_1} - \lambda(0)_{1,max} + 1)}{\Gamma(\lambda(0)_{1,n_1} - \lambda(0)_{1,max} + \mu(0) + 1) \Gamma(-\mu(0))} \\
&\cdot \int_0^x (x - s_0)^{-\mu(0)-1} \frac{x^{-\lambda(0)_{1,max}}}{s_0^{-\lambda(0)_{1,max}}} \prod_{j=2}^p \left(\frac{1 - c_j^{-1} x}{1 - c_j^{-1} s_0}\right)^{-\lambda(0)_{j,max}} v(s_0) ds_0
\end{aligned}$$

and hence we have (10.4). Then the integral expression (10.4) with (10.5), (4.2) and (4.6) inductively proves (10.6) and (10.7).  $\square$

**Example 10.2** (Gauss hypergeometric equation). The reduction (12.55) shows

$$\begin{aligned}\lambda(0)_{j,\nu} &= \lambda_{j,\nu}, \quad m(0)_{j,\nu} = 1 \quad (0 \leq j \leq 2, \quad 1 \leq \nu \leq 2), \quad \mu(0) = -\lambda_{0,2} - \lambda_{1,2} - \lambda_{2,2}, \\ m(1)_{j,1} &= 0, \quad m(1)_{j,2} = 1 \quad (j = 0, 1, 2), \\ \lambda(1)_{0,1} &= \lambda_{0,1} + 2\lambda_{0,2} + 2\lambda_{1,2} + 2\lambda_{2,2}, \quad \lambda(1)_{1,1} = \lambda_{1,1}, \quad \lambda(1)_{2,1} = \lambda_{2,1}, \\ \lambda(1)_{0,2} &= 2\lambda_{0,2} + \lambda_{1,2} + \lambda_{2,2}, \quad \lambda(1)_{1,2} = -\lambda_{0,2} - \lambda_{2,2}, \quad \lambda(1)_{2,2} = -\lambda_{0,2} - \lambda_{1,2}\end{aligned}$$

and therefore

$$\begin{aligned}\lambda(0)_{1,n_1} - \lambda(0)_{1,max} + \mu(0) + 1 &= \lambda_{1,2} - \lambda_{1,1} - (\lambda_{0,2} + \lambda_{1,2} + \lambda_{2,2}) + 1 \\ &= \lambda_{0,1} + \lambda_{1,2} + \lambda_{2,1}, \\ \lambda(0)_{2,max} - \lambda(1)_{2,max} &= \lambda(0)_{2,1} - \lambda(1)_{2,2} = \lambda_{2,1} + \lambda_{0,2} + \lambda_{1,2}.\end{aligned}$$

Hence (10.4) says that the normalized local solution corresponding to the characteristic exponent  $\lambda_{1,2}$  with  $c_1 = 0$  and  $c_2 = 1$  equals

$$(10.9) \quad u(x) = \frac{\Gamma(\lambda_{1,2} - \lambda_{1,1} + 1)x^{\lambda_{1,1}}(1-x)^{\lambda_{2,1}}}{\Gamma(\lambda_{0,1} + \lambda_{1,2} + \lambda_{2,1})\Gamma(\lambda_{0,2} + \lambda_{1,2} + \lambda_{2,2})} \int_0^x (x-s)^{\lambda_{0,2} + \lambda_{1,2} + \lambda_{2,2} - 1} s^{-\lambda_{0,2} - \lambda_{1,1} - \lambda_{2,2}} (1-s)^{-\lambda_{0,2} - \lambda_{1,2} - \lambda_{2,1}} ds$$

and moreover (10.6) says

$$(10.10) \quad u(x) = x^{\lambda_{1,2}}(1-x)^{\lambda_{2,1}} \sum_{\nu=0}^{\infty} \frac{(\lambda_{0,1} + \lambda_{1,2} + \lambda_{2,1})_{\nu} (\lambda_{0,2} + \lambda_{1,2} + \lambda_{2,1})_{\nu}}{(\lambda_{1,2} - \lambda_{1,1} + 1)_{\nu} \nu!} x^{\nu}.$$

Note that  $u(x) = F(a, b, c; x)$  when

$$(10.11) \quad \left\{ \begin{array}{ccc} x = \infty & 0 & 1 \\ \lambda_{0,1} & \lambda_{1,1} & \lambda_{2,1} \\ \lambda_{0,2} & \lambda_{1,2} & \lambda_{2,2} \end{array} \right\} = \left\{ \begin{array}{ccc} x = \infty & 0 & 1 \\ a & 1-c & 0 \\ b & 0 & c-a-b \end{array} \right\}.$$

The integral expression (10.9) is based on the minimal expression  $w = s_{0,1}s_{1,1}s_{1,2}s_0$  satisfying  $w\alpha_{\mathbf{m}} = \alpha_0$ . Here  $\alpha_{\mathbf{m}} = 2\alpha_0 + \sum_{j=0}^2 \alpha_{j,1}$ . When we replace  $w$  and its minimal expression by  $w' = s_{0,1}s_{1,1}s_{1,2}s_0s_{0,1}$  or  $w'' = s_{0,1}s_{1,1}s_{1,2}s_0s_{2,1}$ , we get the different integral expressions

$$(10.12) \quad \begin{aligned}u(x) &= \frac{\Gamma(\lambda_{1,2} - \lambda_{1,1} + 1)x^{\lambda_{1,1}}(1-x)^{\lambda_{2,1}}}{\Gamma(\lambda_{0,2} + \lambda_{1,2} + \lambda_{2,1})\Gamma(\lambda_{0,1} + \lambda_{1,2} + \lambda_{2,2})} \\ &\int_0^x (x-s)^{\lambda_{0,1} + \lambda_{1,2} + \lambda_{2,2} - 1} s^{-\lambda_{0,1} - \lambda_{1,1} - \lambda_{2,2}} (1-s)^{-\lambda_{0,1} - \lambda_{1,2} - \lambda_{2,1}} ds \\ &= \frac{\Gamma(\lambda_{1,2} - \lambda_{1,1} + 1)x^{\lambda_{1,1}}(1-x)^{\lambda_{2,2}}}{\Gamma(\lambda_{0,1} + \lambda_{1,2} + \lambda_{2,2})\Gamma(\lambda_{0,2} + \lambda_{1,2} + \lambda_{2,1})} \\ &\int_0^x (x-s)^{\lambda_{0,2} + \lambda_{1,2} + \lambda_{2,1} - 1} s^{-\lambda_{0,2} - \lambda_{1,1} - \lambda_{2,1}} (1-s)^{-\lambda_{0,2} - \lambda_{1,2} - \lambda_{2,2}} ds.\end{aligned}$$

These give different integral expressions of  $F(a, b, c; x)$  under (10.11).

Since  $s_{\alpha_0 + \alpha_{0,1} + \alpha_{0,2}} \alpha_{\mathbf{m}} = \alpha_{\mathbf{m}}$ , we have

$$\begin{aligned}\left\{ \begin{array}{ccc} x = \infty & 0 & 1 \\ a & 1-c & 0 \\ b & 0 & c-a-b \end{array} \right\} &\xrightarrow{x^{c-1}} \left\{ \begin{array}{ccc} x = \infty & 0 & 1 \\ a-c+1 & 0 & 0 \\ b-c+1 & c-1 & c-a-b \end{array} \right\} \\ \xrightarrow{\partial^{c-d}} \left\{ \begin{array}{ccc} x = \infty & 0 & 1 \\ a-d+1 & 0 & 0 \\ b-d+1 & d-1 & d-a-b \end{array} \right\} &\xrightarrow{x^{1-d}} \left\{ \begin{array}{ccc} x = \infty & 0 & 1 \\ a & 1-d & 0 \\ b & 0 & d-a-b \end{array} \right\}\end{aligned}$$

and hence (cf. (4.6))

$$(10.13) \quad F(a, b, d; x) = \frac{\Gamma(d)x^{1-d}}{\Gamma(c)\Gamma(d-c)} \int_0^x (x-s)^{d-c-1} s^{c-1} F(a, b, c; s) ds.$$

*Remark 10.3.* The integral expression of the local solution  $u(x)$  as is given in Theorem 10.1 is obtained from the expression of the element  $w$  of  $W_\infty$  satisfying  $w\alpha_{\mathbf{m}} \in B \cup \{\alpha_0\}$  as a product of simple reflections and therefore the integral expression depends on such element  $w$  and the expression of  $w$  as such product. The dependence on  $w$  seems non-trivial as in the preceding example but the dependence on the expression of  $w$  as a product of simple reflections is understood as follows.

First note that the integral expression doesn't depend on the coordinate transformations  $x \mapsto ax$  and  $x \mapsto x + b$  with  $a \in \mathbb{C}^\times$  and  $b \in \mathbb{C}$ . Since

$$\begin{aligned} \int_c^x (x-t)^{\mu-1} \phi(t) dt &= - \int_{\frac{1}{c}}^{\frac{1}{x}} (x-\frac{1}{s})^{\mu-1} \phi(\frac{1}{s}) s^{-2} ds \\ &= -(-1)^{\mu-1} x^{\mu-1} \int_{\frac{1}{c}}^{\frac{1}{x}} (\frac{1}{x}-s)^{\mu-1} (\frac{1}{s})^{\mu+1} \phi(\frac{1}{s}) ds, \end{aligned}$$

we have

$$(10.14) \quad I_c^\mu(\phi) = -(-1)^{\mu-1} x^{\mu-1} \left( I_{\frac{1}{c}}^x (x^{\mu+1} \phi(x)) \Big|_{x \mapsto \frac{1}{x}} \right) \Big|_{x \mapsto \frac{1}{x}},$$

which corresponds to (7.11). Here the value  $(-1)^{\mu-1}$  depends on the branch of the value of  $(x-\frac{1}{s})^{\mu-1}$  and that of  $x^{\mu-1} x^{1-\mu} (\frac{1}{x}-s)^{\mu-1}$ .

Hence the argument as in the proof of Theorem 9.5 shows that the dependence on the expression of  $w$  by a product of simple reflections can be understood by the identities (10.14) and  $I_c^{\mu_1} I_c^{\mu_2} = I_c^{\mu_1+\mu_2}$  (cf. (4.4)) etc.

## 11. MONODROMY

The transformation of monodromy generators for irreducible Fuchsian systems of Schlesinger canonical form under the middle convolution or the addition is studied by [Kz] and [DR, DR2] etc. A non-zero homomorphism of an irreducible single Fuchsian differential equation to an irreducible system of Schlesinger canonical form induces the isomorphism of their monodromies of the solutions (cf. Remark 2.12). In particular since any rigid local system is realized by a single Fuchsian differential equation, their monodromies naturally coincide with each other through the correspondence of their monodromy generators. The correspondence between the local monodromies and the global monodromies is described by [DR2], which we will review.

**11.1. Middle convolution of monodromies.** For given matrices  $A_j \in M(n, \mathbb{C})$  for  $j = 1, \dots, p$  the Fuchsian system

$$(11.1) \quad \frac{dv}{dx} = \sum_{j=1}^p \frac{A_j}{x-c_j} v$$

of Schlesinger canonical form (SCF) is defined. Put  $A_0 = -A_1 - \dots - A_p$  and  $\mathbf{A} = (A_0, A_1, \dots, A_p)$  which is an element of

$$(11.2) \quad M(n, \mathbb{C})_0^{p+1} := \{(C_0, \dots, C_p) \in M(n, \mathbb{C})^{p+1}; C_0 + \dots + C_p = 0\},$$

The Riemann scheme of (11.1) is defined by

$$(11.3) \quad \left\{ \begin{array}{cccc} x = c_0 = \infty & c_1 & \cdots & c_p \\ [\lambda_{0,1}]_{m_{0,1}} & [\lambda_{1,1}]_{m_{1,1}} & \cdots & [\lambda_{p,1}]_{m_{p,1}} \\ \vdots & \vdots & \vdots & \vdots \\ [\lambda_{0,n_0}]_{m_{0,n_0}} & [\lambda_{1,n_1}]_{m_{1,n_1}} & \cdots & [\lambda_{p,n_p}]_{m_{p,1}} \end{array} \right\}, \quad [\lambda]_k := \begin{pmatrix} \lambda \\ \vdots \\ \lambda \end{pmatrix} \in M(1, k, \mathbb{C})$$

if

$$A_j \sim L(m_{j,1}, \dots, m_{j,n_j}; \lambda_{j,1}, \dots, \lambda_{j,n_j}) \quad (j = 0, \dots, p)$$

under the notation (6.33). Here the Fuchs relation equals

$$(11.4) \quad \sum_{j=0}^p \sum_{\nu=1}^{n_j} m_{j,\nu} \lambda_{j,\nu} = 0.$$

We define that  $\mathbf{A}$  is *irreducible* if a subspace  $V$  of  $\mathbb{C}^n$  satisfies  $A_j V \subset V$  for  $j = 0, \dots, p$ , then  $V = \{0\}$  or  $V = \mathbb{C}^n$ . In general,  $\mathbf{A} = (A_0, \dots, A_p)$ ,  $\mathbf{A}' = (A'_0, \dots, A'_p) \in M(n, \mathbb{C})^{p+1}$ , we denote by  $\mathbf{A} \sim \mathbf{A}'$  if there exists  $U \in GL(n, \mathbb{C})$  such that  $A'_j = U A_j U^{-1}$  for  $j = 0, \dots, p$ .

For  $(\mu_0, \dots, \mu_p) \in \mathbb{C}^{p+1}$  with  $\mu_0 + \dots + \mu_p = 0$ , the addition  $\mathbf{A}' = (A'_0, \dots, A'_p) \in M(n, \mathbb{C})_0^{p+1}$  of  $\mathbf{A}$  with respect to  $(\mu_0, \dots, \mu_p)$  is defined by  $A'_j = A_j + \mu_j$  for  $j = 0, \dots, p$ .

For a complex number  $\mu$  the middle convolution  $\bar{\mathbf{A}} := mc_\mu(\mathbf{A})$  of  $\mathbf{A}$  is defined by  $\bar{A}_j = \bar{A}_j(\mu)$  for  $j = 1, \dots, p$  and  $\bar{A}_0 = -\bar{A}_1 - \dots - \bar{A}_p$  under the notation in §2.5. Then we have the following theorem.

**Theorem 11.1** ([DR, DR2]). *Suppose that  $\mathbf{A}$  satisfies the conditions*

$$(11.5) \quad \bigcap_{\substack{1 \leq j \leq p \\ j \neq i}} \ker A_j \cap \ker(A_0 - \tau) = \{0\} \quad (i = 1, \dots, p, \forall \tau \in \mathbb{C}),$$

$$(11.6) \quad \bigcap_{\substack{1 \leq j \leq p \\ j \neq i}} \ker {}^t A_j \cap \ker({}^t A_0 - \tau) = \{0\} \quad (i = 1, \dots, p, \forall \tau \in \mathbb{C}).$$

i) *The tuple  $mc_\mu(\mathbf{A}) = (\bar{A}_0, \dots, \bar{A}_p)$  also satisfies the same conditions as above with replacing  $A_\nu$  by  $\bar{A}_\nu$  for  $\nu = 0, \dots, p$ , respectively. Moreover we have*

$$(11.7) \quad mc_\mu(\mathbf{A}) \sim mc_\mu(\mathbf{A}') \quad \text{if } \mathbf{A} \sim \mathbf{A}',$$

$$(11.8) \quad mc_{\mu'} \circ mc_\mu(\mathbf{A}) \sim mc_{\mu+\mu'}(\mathbf{A}),$$

$$(11.9) \quad mc_0(\mathbf{A}) \sim \mathbf{A}$$

and  $\mathbf{A}$  is irreducible if and only if  $\mathbf{A}'$  is irreducible.

ii) (cf. [O6, Theorem 5.2]) *Assume*

$$(11.10) \quad \mu = \lambda_{0,1} \neq 0 \quad \text{and} \quad \lambda_{j,1} = 0 \quad \text{for } j = 1, \dots, p$$

and

$$(11.11) \quad \lambda_{j,\nu} = \lambda_{j,1} \quad \text{implies} \quad m_{j,\nu} \leq m_{j,1}$$

for  $j = 0, \dots, p$  and  $\nu = 2, \dots, n_j$ . Then the Riemann scheme of  $mc_\mu(\mathbf{A})$  equals

$$(11.12) \quad \left\{ \begin{array}{cccc} x = \infty & c_1 & \cdots & c_p \\ [-\mu]_{m_{0,1}-d} & [0]_{m_{1,1}-d} & \cdots & [0]_{m_{p,1}-d} \\ [\lambda_{0,2} - \mu]_{m_{0,2}} & [\lambda_{1,2} + \mu]_{m_{1,2}} & \cdots & [\lambda_{p,2} + \mu]_{m_{p,2}} \\ \vdots & \vdots & \vdots & \vdots \\ [\lambda_{0,n_0} - \mu]_{m_{0,n_0}} & [\lambda_{1,n_1} + \mu]_{m_{1,n_1}} & \cdots & [\lambda_{p,n_p} + \mu]_{m_{p,1}} \end{array} \right\}$$



with

$$(11.13) \quad d := m_{0,1} + \cdots + m_{p,1} - (p-1) \text{ ord } \mathbf{m}.$$

**Example 11.2.** The addition of

$$mc_{-\lambda_{0,1}-\lambda_{1,2}-\lambda_{2,2}}(\{\lambda_{0,2} - \lambda_{0,1}, \lambda_{0,1} + \lambda_{1,1} + \lambda_{2,2}, \lambda_{0,1} + \lambda_{1,2} + \lambda_{2,1}\})$$

with respect to  $(-\lambda_{1,2} - \lambda_{2,2}, \lambda_{1,2}, \lambda_{2,2})$  give the Fuchsian system of Schlesinger canonical form

$$\frac{du}{dx} = \frac{A_1}{x}u + \frac{A_2}{x-1}u,$$

$$A_1 = \begin{pmatrix} \lambda_{1,1} & \lambda_{0,1} + \lambda_{1,2} + \lambda_{2,1} \\ & \lambda_{1,2} \end{pmatrix} \quad \text{and} \quad A_2 = \begin{pmatrix} & \lambda_{2,2} \\ \lambda_{0,1} + \lambda_{1,1} + \lambda_{2,2} & \lambda_{2,1} \end{pmatrix}.$$

with the Riemann scheme

$$\left\{ \begin{array}{ccc} x = \infty & 0 & 1 \\ \lambda_{0,1} & \lambda_{1,1} & \lambda_{2,1} \\ \lambda_{0,2} & \lambda_{1,2} & \lambda_{2,2} \end{array} \right\} \quad (\lambda_{0,1} + \lambda_{0,2} + \lambda_{1,1} + \lambda_{1,2} + \lambda_{2,1} + \lambda_{2,2} = 0).$$

The system is invariant as  $W(x; \lambda_{j,\nu})$ -modules under the transformation  $\lambda_{j,\nu} \mapsto \lambda_{j,3-\nu}$  for  $j = 0, 1, 2$  and  $\nu = 1, 2$ .

Suppose  $\lambda_{j,\nu}$  are generic complex numbers under the condition  $\lambda_{0,1} + \lambda_{1,2} + \lambda_{2,1} = \lambda_{0,2} + \lambda_{1,1} + \lambda_{2,2} = 0$ . Then  $A_1$  and  $A_2$  have a unique simultaneous eigenspace. In fact,  $A_1 \binom{0}{1} = \lambda_{1,2} \binom{0}{1}$  and  $A_2 \binom{0}{1} = \lambda_{2,1} \binom{0}{1}$ . Hence the system is not invariant as  $W(x)$ -modules under the transformation above and  $\mathbf{A}$  is not irreducible in this case.

To describe the monodromies, we review the multiplicative version of these operations.

Let  $\mathbf{M} = (M_0, \dots, M_p)$  be an element of

$$(11.14) \quad GL(n, \mathbb{C})_1^{p+1} := \{(G_0, \dots, G_p) \in GL(n, \mathbb{C})^{p+1}; G_p \cdots G_0 = I_n\}.$$

For  $(\rho_0, \dots, \rho_p) \in \mathbb{C}^{p+1}$  satisfying  $\rho_0 \cdots \rho_p = 1$ , the *multiplication* of  $\mathbf{M}$  with respect to  $\rho$  is defined by  $(\rho_0 M_0, \dots, \rho_p M_p)$ .

For a given  $\rho \in \mathbb{C}^\times$ , we define  $\tilde{M}_j = (M_{j,\nu,\nu'})_{\substack{1 \leq \nu \leq n \\ 1 \leq \nu' \leq p}} \in GL(pn, \mathbb{C})$  by

$$\tilde{M}_{j,\nu,\nu'} = \begin{cases} \delta_{\nu,\nu'} I_n & (\nu \neq j), \\ M_{\nu'} - 1 & (\nu = j, 1 \leq \nu' \leq j-1), \\ \rho M_j & (\nu = \nu' = j), \\ \rho(M_{\nu'} - 1) & (\nu = j, j+1 \leq \nu' \leq p). \end{cases}$$

Let  $\bar{M}_j$  denote the quotient  $\tilde{M}_j|_{\mathbb{C}^{pn}/V}$  of

$$(11.15) \quad \tilde{M}_j = \begin{pmatrix} I_n & & & & \\ & \ddots & & & \\ & & \rho M_j & \cdots & \rho(M_p - 1) \\ & & & \ddots & \\ & & & & I_n \end{pmatrix} \in GL(pn, \mathbb{C})$$

for  $j = 1, \dots, p$  and  $M_0 = (M_p \cdots M_1)^{-1}$ . The tuple  $\text{MC}_\rho(\mathbf{M}) = (\bar{M}_0, \dots, \bar{M}_p)$  is called (the multiplicative version of) the middle convolution of  $\mathbf{M}$  with respect to  $\rho$ . Here  $V := \ker(\tilde{M} - 1) + \bigcap_{j=1}^p \ker(\tilde{M}_j - 1)$  with

$$\tilde{M} := \begin{pmatrix} M_1 & & \\ & \ddots & \\ & & M_p \end{pmatrix}.$$

Then we have the following theorem.

**Theorem 11.3** ([DR, DR2]). *Let  $\mathbf{M} = (M_0, \dots, M_p) \in GL(n, \mathbb{C})_1^{p+1}$ . Suppose*

$$(11.16) \quad \bigcap_{\substack{1 \leq \nu \leq p \\ \nu \leq i}} \ker(M_\nu - 1) \cap \ker(M_i - \tau) = \{0\} \quad (1 \leq i \leq p, \forall \tau \in \mathbb{C}^\times),$$

$$(11.17) \quad \bigcap_{\substack{1 \leq \nu \leq p \\ \nu \leq i}} \ker({}^t M_\nu - 1) \cap \ker({}^t M_i - \tau) = \{0\} \quad (1 \leq i \leq p, \forall \tau \in \mathbb{C}^\times).$$

i) *The tuple  $\text{MC}_\rho(\mathbf{M}) = (\bar{M}_0, \dots, \bar{M}_p)$  also satisfies the same conditions as above with replacing  $M_\nu$  by  $\bar{M}_\nu$  for  $\nu = 0, \dots, p$ , respectively. Moreover we have*

$$(11.18) \quad \text{MC}_\rho(\mathbf{M}) \sim \text{MC}_\rho(\mathbf{M}') \quad \text{if } \mathbf{M} \sim \mathbf{M}',$$

$$(11.19) \quad \text{MC}_{\rho'} \circ \text{MC}_\rho(\mathbf{M}) \sim \text{MC}_{\rho\rho'}(\mathbf{M}),$$

$$(11.20) \quad \text{MC}_1(\mathbf{M}) \sim \mathbf{M}$$

and  $\text{MC}_\rho(\mathbf{M})$  is irreducible if and only if  $\mathbf{M}$  is irreducible.

ii) *Assume*

$$(11.21) \quad M_j \sim L(m_{j,1}, \dots, m_{j,n_j}; \rho_{j,1}, \dots, \rho_{j,n_j}) \quad \text{for } j = 0, \dots, p,$$

$$(11.22) \quad \rho = \rho_{0,1} \neq 1 \quad \text{and} \quad \rho_{j,1} = 1 \quad \text{for } j = 1, \dots, p$$

and

$$(11.23) \quad \rho_{j,\nu} = \rho_{j,1} \quad \text{implies} \quad m_{j,\nu} \leq m_{j,1}$$

for  $j = 0, \dots, p$  and  $\nu = 2, \dots, n_j$ . In this case, we say that  $\mathbf{M}$  has a spectral type  $\mathbf{m} := (\mathbf{m}_0, \dots, \mathbf{m}_p)$  with  $\mathbf{m}_j = (m_{j,1}, \dots, m_{j,n_j})$ .

Putting  $(\bar{M}_0, \dots, \bar{M}_p) = \text{MC}_\rho(M_0, \dots, M_p)$ , we have

$$(11.24) \quad \bar{M}_j \sim \begin{cases} L(m_{0,1} - d, m_{0,2}, \dots, m_{0,n_0}; \rho^{-1}, \rho^{-1}\rho_{0,2}, \dots, \rho^{-1}\rho_{0,n_0}) & (j = 0), \\ L(m_{j,1} - d, m_{j,2}, \dots, m_{j,n_j}; 1, \rho\rho_{j,2}, \dots, \rho\rho_{j,n_j}) & (j = 1, \dots, p). \end{cases}$$

Here  $d$  is given by (11.13).

*Remark 11.4.* i) We note that some  $m_{j,1}$  may be zero in Theorem 11.1 and Theorem 11.3.

ii) It follows from Theorem 11.1 (resp. Theorem 11.3) and Scott's lemma that any irreducible tuple  $\mathbf{A} \in M(n, \mathbb{C})_0^{p+1}$  (resp.  $\mathbf{M} \in GL(n, \mathbb{C})_1^{p+1}$ ) can be connected by successive applications of middle convolutions and additions (resp. multiplications) to an tuple whose spectral type is fundamental (cf. Definition 8.14). In particular, the spectral type of  $\mathbf{M}$  is an irreducibly realizable tuple if  $\mathbf{M}$  is irreducible.

**Definition 11.5.** Let  $\mathbf{M} = (M_0, \dots, M_p) \in GL(n, \mathbb{C})_1^{p+1}$ . Suppose (11.21). Fix  $\ell = (\ell_0, \dots, \ell_p) \in \mathbb{Z}_{\geq 1}^{p+1}$  and define  $\partial_\ell \mathbf{M}$  as follows.

$$\rho_j := \begin{cases} \rho_{j,\ell_j} & (0 \leq j \leq p, 1 \leq \ell_j \leq n_j), \\ \text{any complex number} & (0 \leq j \leq p, n_j < \ell_j), \end{cases}$$

$$\rho := \rho_0 \rho_1 \dots \rho_p,$$

$$(M'_0, \dots, M'_p) := \text{MC}_\rho(\rho_1 \dots \rho_p M_0, \rho_1^{-1} M_1, \rho_2^{-1} M_2, \dots, \rho_p^{-1} M_p),$$

$$\partial_\ell \mathbf{M} := (\rho_1^{-1} \dots \rho_p^{-1} M'_0, \rho_1 M'_1, \rho_2 M'_2, \dots, \rho_p M'_p).$$

Here we note that if  $\ell = (1, \dots, 1)$  and  $\rho_{j,1} = 1$  for  $j = 2, \dots, p$ ,  $\partial_\ell \mathbf{M} = \text{MC}_\rho(\mathbf{M})$ .

Let  $u(1), \dots, u(n)$  be independent solutions of (11.1) at a generic point  $q$ . Let  $\gamma_j$  be a closed path around  $c_j$  as in the following figure. Denoting the result of the analytic continuation of  $\tilde{u} := (u(1), \dots, u(n))$  along  $\gamma_j$  by  $\gamma_j(\tilde{u})$ , we have a *monodromy generator*  $M_j \in GL(n, \mathbb{C})$  such that  $\gamma_j(\tilde{u}) = \tilde{u}M_j$ . We call the tuple  $\mathbf{M} = (M_0, \dots, M_p)$  the *monodromy* of (11.1) with respect to  $\tilde{u}$  and  $\gamma_0, \dots, \gamma_p$ . The connecting path first going along  $\gamma_i$  and then going along  $\gamma_j$  is denoted by  $\gamma_i \circ \gamma_j$ .

$$\begin{aligned} \gamma_i \circ \gamma_j(\tilde{u}) &= \gamma_j(\tilde{u}M_i) \\ &= \gamma_j(\tilde{u})M_i \\ &= \tilde{u}M_jM_i, \\ M_pM_{p-1} \cdots M_1M_0 &= I_n. \end{aligned}$$

(11.25)

The following theorem says that the monodromy of solutions of the system obtained by a middle convolution of the system (11.1) is a multiplicative middle convolution of that of the original system (11.1).

**Theorem 11.6** ([DR2]). *Let  $\text{Mon}(\mathbf{A})$  denote the monodromy of the equation (11.1). Put  $\mathbf{M} = \text{Mon}(\mathbf{A})$ . Suppose  $\mathbf{M}$  satisfies (11.16) and (11.17) and*

$$(11.26) \quad \text{rank}(A_0 - \mu) = \text{rank}(M_0 - e^{2\pi\sqrt{-1}\mu}),$$

$$(11.27) \quad \text{rank}(A_j) = \text{rank}(M_j - 1)$$

for  $j = 1, \dots, p$ , then

$$(11.28) \quad \text{Mon}(mc_\mu(\mathbf{A})) \sim \text{MC}_{e^{2\pi\sqrt{-1}\mu}}(\text{Mon}(\mathbf{A})).$$

Let  $\mathcal{F}$  be a space of (multi-valued) holomorphic functions on  $\mathbb{C} \setminus \{c_1, \dots, c_p\}$  valued in  $\mathbb{C}^n$  such that  $\mathcal{F}$  satisfies (3.15), (3.16) and (3.17). For example the solutions of the equation (11.1) defines  $\mathcal{F}$ . Fixing a base  $u = (u(1), \dots, u(n))$  of  $\mathcal{F}(U)$  with  $U \ni q$ , we can define monodromy generators  $(M_0, \dots, M_p)$ . Fix  $\mu \in \mathbb{C}$  and put  $\rho = e^{2\pi\sqrt{-1}\mu}$  and

$$v_j(x) = \begin{pmatrix} \int^{(x+, c_j+, x-, c_j-)} \frac{u(t)(x-t)^{\mu-1}}{t-c_1} dt \\ \vdots \\ \int^{(x+, c_j+, x-, c_j-)} \frac{u(t)(x-t)^{\mu-1}}{t-c_p} dt \end{pmatrix} \quad \text{and} \quad v(x) = (v_1(x), \dots, v_p(x)).$$

Then  $v(x)$  is a holomorphic function valued in  $M(pn, \mathbb{C})$  and the  $pn$  column vectors of  $v(x)$  define a *convolution*  $\tilde{\mathcal{F}}$  of  $\mathcal{F}$  and the following facts are shown by [DR2].

The monodromy generators of  $\tilde{\mathcal{F}}$  with respect to the base  $v(x)$  equals the *convolution*  $\tilde{\mathbf{M}} = (\tilde{M}_0, \dots, \tilde{M}_1)$  of  $\mathbf{M}$  given by (11.15) and if  $\mathcal{F}$  corresponds to the space of solutions of (2.74),  $\tilde{\mathcal{F}}$  corresponds to that of the system of Schlesinger canonical form defined by  $(\tilde{A}_0(\mu), \dots, \tilde{A}_p(\mu))$  in (2.77), which we denote by  $\mathcal{M}_{\tilde{\mathbf{A}}}$ .

The middle convolution  $\text{MC}_\rho(\mathbf{M})$  of  $\mathbf{M}$  is the induced monodromy generators on the quotient space of  $\mathbb{C}^{pn}/V$  where  $V$  is the maximal invariant subspace such the restriction of  $\tilde{\mathbf{M}}$  on  $V$  is a direct sum of finite copies of 1-dimensional spaces with

the actions  $(\rho^{-1}, 1, \dots, 1, \overset{j}{\rho}, 1, \dots, 1) \in GL(1, \mathbb{C})^{p+1}$  ( $j = 1, \dots, p$ ) and  $(1, 1, \dots, 1)$ . The system defined by the middle convolution  $mc_\mu(\mathbf{A})$  is the quotient of the system  $\mathcal{M}_{\tilde{\mathbf{A}}}$  by the maximal submodule such that the submodule is a direct sum of finite copies of the equations  $(x - c_j) \frac{dw}{dx} = \mu w$  ( $j = 1, \dots, p$ ) and  $\frac{dw}{dx} = 0$ .

Suppose  $\mathbf{M}$  and  $\text{MC}_\rho(\mathbf{M})$  are irreducible and  $\rho \neq 1$ . Assume  $\phi(x)$  is a function belonging to  $\mathcal{F}$  such that it is defined around  $x = c_j$  and corresponds to the eigenvector of the monodromy matrix  $M_j$  with the eigenvalue different from 1. Then the holomorphic continuation of  $\Phi(x) = \int^{(x+, c_j+, x-, c_j-)} \frac{\phi(t)(t-x)^\mu}{t-c_j} dt$  defines the monodromy isomorphic to  $\text{MC}_\rho(\mathbf{M})$ .

*Remark 11.7.* We can define the monodromy  $\mathbf{M} = (M_0, \dots, M_p)$  of the universal model  $P_{\mathbf{m}}u = 0$  (cf. Theorem 8.13) so that  $\mathbf{M}$  is entire holomorphic with respect to the spectral parameters  $\lambda_{j,\nu}$  and the accessory parameters  $g_i$  under the normalization  $u(j)^{(\nu-1)}(q) = \delta_{j,\nu}$  for  $j, \nu = 1, \dots, n$  and  $q \in \mathbb{C} \setminus \{c_1, \dots, c_p\}$ . Here  $u(1), \dots, u(n)$  are solutions of  $P_{\mathbf{m}}u = 0$ .

**Definition 11.8.** Let  $P$  be a Fuchsian differential operator with the Riemann scheme (6.15) and the spectral type  $\mathbf{m} = (m_{j,\nu})_{\substack{0 \leq j \leq p \\ 1 \leq \nu \leq n_j}}$ . We define that  $P$  is *locally non-degenerate* if the tuple of the monodromy generators  $\mathbf{M} := (M_0, \dots, M_p)$  satisfies

$$(11.29) \quad M_j \sim L(m_{j,1}, \dots, m_{j,n_j}; e^{2\pi\sqrt{-1}\lambda_{j,1}}, \dots, e^{2\pi\sqrt{-1}\lambda_{j,n_j}}) \quad (j = 0, \dots, p),$$

which is equivalent to the condition that

$$(11.30) \quad \dim Z(M_j) = m_{j,1}^2 + \dots + m_{j,n_j}^2 \quad (j = 0, \dots, p).$$

Suppose  $\mathbf{m}$  is irreducibly realizable. Let  $P_{\mathbf{m}}$  be the universal operator with the Riemann scheme (6.15). We say that the parameters  $\lambda_{j,\nu}$  and  $g_i$  are *locally non-degenerate* if the corresponding operator is locally non-degenerate.

Note that the parameters are locally non-degenerate if

$$\lambda_{j,\nu} - \lambda_{j,\nu'} \notin \mathbb{Z} \quad (j = 0, \dots, p, \nu = 1, \dots, n_j, \nu' = 1, \dots, n_j).$$

Define  $P_t$  as in Remark 6.4 iv). Then we can define monodromy generator  $M_t$  of  $P_t$  at  $x = c_j$  so that  $M_t$  holomorphically depend on  $t$  (cf. Remark 11.7). Then Remark 6.13 v) proves that (11.30) implies (11.29) for every  $j$ .

The following proposition gives a sufficient condition such that an operator is locally non-degenerate.

**Proposition 11.9.** *Let  $P$  be a Fuchsian differential operator with the Riemann scheme (6.15) and let  $M_j$  be the monodromy generator at  $x = c_j$ . Fix an integer  $j$  with  $0 \leq j \leq p$ . Then the condition*

$$(11.31) \quad \begin{aligned} &\lambda_{j,\nu} - \lambda_{j,\nu'} \notin \mathbb{Z} \text{ or } (\lambda_{j,\nu} - \lambda_{j,\nu'}) (\lambda_{j,\nu} + m_{j,\nu} - \lambda_{j,\nu'} - m_{j,\nu'}) \leq 0 \\ &\text{for } 1 \leq \nu \leq n_j \text{ and } 1 \leq \nu' \leq n_j \end{aligned}$$

*implies  $\dim Z(M_j) = m_{j,1}^2 + \dots + m_{j,n_j}^2$ . In particular,  $P$  is locally non-degenerate if (11.31) is valid for  $j = 0, \dots, p$ .*

*Here we remark that the following condition implies (11.31).*

$$(11.32) \quad \lambda_{j,\nu} - \lambda_{j,\nu'} \notin \mathbb{Z} \setminus \{0\} \quad \text{for } 1 \leq \nu \leq n_j \text{ and } 1 \leq \nu' \leq n_j.$$

*Proof.* For  $\mu \in \mathbb{C}$  we put

$$N_\mu = \{\nu; 1 \leq \nu \leq n_j, \mu \in \{\lambda_{j,\nu}, \lambda_{j,\nu} + 1, \dots, \lambda_{j,\nu} + m_{j,\nu} - 1\}\}.$$

If  $N_\mu > 0$ , we have a local solution  $u_{\mu,\nu}(x)$  of the equation  $Pu = 0$  such that

$$(11.33) \quad u_{\mu,\nu}(x) = (x - c_j)^\mu \log^\nu(x - c_j) + \mathcal{O}_{c_j}(\mu + 1, L_\nu) \quad \text{for } \nu = 0, \dots, N_\mu - 1.$$

Here  $L_\nu$  are positive integers and if  $j = 0$ , then  $x$  and  $x - c_j$  should be replaced by  $y = \frac{1}{x}$  and  $y$ , respectively.

Suppose (11.31). Put  $\rho = e^{2\pi\mu i}$ ,  $\mathbf{m}'_\rho = \{m_{j,\nu}; \lambda_{j,\nu} - \mu \in \mathbb{Z}\}$  and  $\mathbf{m}'_\rho = \{m'_{\rho,1}, \dots, m'_{\rho,n_\rho}\}$  with  $m'_{\rho,1} \geq m'_{\rho,2} \geq \dots \geq m'_{\rho,n_\rho} \geq 1$ . Then (11.31) implies

$$(11.34) \quad n - \text{rank}(M_j - \rho)^k \leq \begin{cases} m'_{\rho,1} + \dots + m'_{\rho,k} & (1 \leq k \leq n_\rho), \\ m'_{\rho,1} + \dots + m'_{\rho,n_\rho} & (n_\rho < k). \end{cases}$$

The above argument proving (11.29) under the condition (11.30) shows that the left hand side of (11.34) is not smaller than the right hand side of (11.34). Hence we have the equality in (11.34). Thus we have (11.30) and we can assume that  $L_\nu = \nu$  in (11.33).  $\square$

Theorem 11.3, Theorem 11.6 and Proposition 4.1 show the following corollary. One can also prove it by the same way as in the proof of [DR2, Theorem 4.7].

**Corollary 11.10.** *Let  $P$  be a Fuchsian differential operator with the Riemann scheme (6.15). Let  $\text{Mon}(P)$  denote the monodromy of the equation  $Pu = 0$ . Put  $\text{Mon}(P) = (M_0, \dots, M_p)$ . Suppose*

$$(11.35) \quad M_j \sim L(m_{j,1}, \dots, m_{j,n_j}; e^{2\pi\sqrt{-1}\lambda_{j,1}}, \dots, e^{2\pi\sqrt{-1}\lambda_{j,n_j}}) \quad \text{for } j = 0, \dots, p.$$

*In this case,  $P$  is said to be locally non-degenerate. Under the notation in Definition 7.6, we fix  $\ell \in \mathbb{Z}_{\geq 1}^{p+1}$  and suppose (7.23). Assume moreover*

$$(11.36) \quad \mu_\ell \notin \mathbb{Z},$$

$$(11.37) \quad m_{j,\nu} \leq m_{j,\ell_j} \quad \text{or} \quad \lambda_{j,\ell_j} - \lambda_{j,\nu} \notin \mathbb{Z} \quad (j = 0, \dots, p, \nu = 1, \dots, n_j).$$

*Then we have*

$$(11.38) \quad \text{Mon}(\partial_\ell P) \sim \partial_\ell \text{Mon}(P).$$

*In particular,  $\text{Mon}(P)$  is irreducible if and only if  $\text{Mon}(\partial_\ell P)$  is irreducible.*

**11.2. Scott's lemma and Katz's rigidity.** The results in this subsection are known but we will review them with their proof for the completeness of this paper.

**Lemma 11.11** (Scott [Sc]). *Let  $\mathbf{M} \in GL(n, \mathbb{C})_1^{p+1}$  and  $\mathbf{A} \in M(n, \mathbb{C})_0^{p+1}$  under the notation (11.2) and (11.14). Then*

$$(11.39) \quad \sum_{j=0}^p \text{codim ker}(M_j - 1) \geq \text{codim} \bigcap_{j=0}^p \text{ker}(M_j - 1) + \text{codim} \bigcap_{j=0}^p \text{ker}({}^t M_j - 1),$$

$$(11.40) \quad \sum_{j=0}^p \text{codim ker } A_j \geq \text{codim} \bigcap_{j=0}^p \text{ker } A_j + \text{codim} \bigcap_{j=0}^p \text{ker } {}^t A_j.$$

*In particular, if  $\mathbf{M}$  and  $\mathbf{A}$  are irreducible, then*

$$(11.41) \quad \sum_{j=0}^p \text{dim ker}(M_j - 1) \leq (p-1)n,$$

$$(11.42) \quad \sum_{j=0}^p \text{dim ker } A_j \leq (p-1)n.$$

*Proof.* Consider the following linear maps:

$$V = \text{Im}(M_0 - 1) \times \dots \times \text{Im}(M_p - 1) \subset \mathbb{C}^{n(p+1)},$$

$$\beta : \mathbb{C}^n \rightarrow V, \quad v \mapsto ((M_0 - 1)v, \dots, (M_p - 1)v),$$

$$\delta : V \rightarrow \mathbb{C}^n, \quad (v_0, \dots, v_p) \mapsto M_p \cdots M_1 v_0 + M_p \cdots M_2 v_1 + \dots + M_p v_{p-1} + v_p.$$

Since  $M_p \cdots M_1(M_0 - 1) + \cdots + M_p(M_{p-1} - 1) + (M_p - 1) = M_p \cdots M_1 M_0 - 1 = 0$ , we have  $\delta \circ \beta = 0$ . Moreover we have

$$\begin{aligned} \sum_{j=0}^p M_p \cdots M_{j+1} (M_j - 1) v_j &= \sum_{j=0}^p \left( 1 + \sum_{\nu=j+1}^p (M_\nu - 1) M_{\nu-1} \cdots M_{j+1} \right) (M_j - 1) v_j \\ &= \sum_{j=0}^p (M_j - 1) v_j + \sum_{\nu=1}^p \sum_{i=0}^{\nu-1} (M_\nu - 1) M_{\nu-1} \cdots M_{i+1} (M_i - 1) v_i \\ &= \sum_{j=0}^p (M_j - 1) \left( v_j + \sum_{i=0}^{j-1} M_{j+1} \cdots M_{i+1} (M_i - 1) v_i \right) \end{aligned}$$

and therefore  $\text{Im } \delta = \sum_{j=0}^p \text{Im}(M_j - 1)$ . Hence

$$\dim \text{Im } \delta = \text{rank}(M_0 - 1, \dots, M_p - 1) = \text{rank} \begin{pmatrix} {}^t M_0 - 1 \\ \vdots \\ {}^t M_p - 1 \end{pmatrix}$$

and

$$\begin{aligned} \sum_{j=0}^p \text{codim } \ker(M_j - 1) &= \dim V = \dim \ker \delta + \dim \text{Im } \delta \\ &\geq \dim \text{Im } \beta + \dim \text{Im } \delta \\ &= \text{codim} \bigcap_{j=0}^p \ker(M_j - 1) + \text{codim} \bigcap_{j=0}^p \ker({}^t M_j - 1). \end{aligned}$$

Putting

$$\begin{aligned} V &= \text{Im } A_0 \times \cdots \times \text{Im } A_p \subset \mathbb{C}^{n(p+1)}, \\ \beta : \mathbb{C}^n &\rightarrow V, \quad v \mapsto (A_0 v, \dots, A_p v), \\ \delta : V &\rightarrow \mathbb{C}^n, \quad (v_0, \dots, v_p) \mapsto v_0 + v_1 + \cdots + v_p, \end{aligned}$$

we have the claims for  $\mathbf{A} \in M(n, \mathbb{C})^{p+1}$  in the same way as in the proof for  $\mathbf{M} \in GL(n, \mathbb{C})_1^{p+1}$ .  $\square$

**Corollary 11.12** (Katz [Kz] and [SV]). *Let  $\mathbf{M} \in GL(n, \mathbb{C})_1^{p+1}$ . The dimensions of the manifolds*

$$(11.43) \quad V_1 := \{\mathbf{H} \in GL(n, \mathbb{C})_1^{p+1}; \mathbf{H} \sim \mathbf{M}\}$$

and

$$(11.44) \quad V_2 := \{\mathbf{H} \in GL(n, \mathbb{C})_1^{p+1}; H_j \sim M_j \quad (j = 0, \dots, p)\}$$

are give by

$$(11.45) \quad \dim V_1 = \text{codim } Z(\mathbf{M}),$$

$$(11.46) \quad \dim V_2 = \sum_{j=0}^p \text{codim } Z(M_j) - \text{codim } Z(\mathbf{M}).$$

Here  $Z(\mathbf{M}) := \bigcap_{j=0}^p Z(M_j)$  and  $Z(M_i) = \{X \in M(n, \mathbb{C}); XM_j = M_j X\}$ .

Suppose  $\mathbf{M}$  is irreducible. Then  $\text{codim } Z(\mathbf{M}) = n^2 - 1$  and

$$(11.47) \quad \sum_{j=0}^p \text{codim } Z(M_j) \geq 2n^2 - 2.$$

Moreover  $\mathbf{M}$  is rigid, namely,  $V_1 = V_2$  if and only if  $\sum_{j=0}^p \text{codim } Z(M_j) = 2n^2 - 2$ .

*Proof.* The group  $GL(n, \mathbb{C})$  transitively acts on  $V_1$  as simultaneous conjugations and the isotropy group with respect to  $\mathbf{M}$  equals  $Z(\mathbf{M})$  and hence  $\dim V_1 = \text{codim } Z(\mathbf{M})$ .

The group  $GL(n, \mathbb{C})^{p+1}$  naturally acts on  $GL(n, \mathbb{C})^{p+1}$  by conjugations. Putting  $L = \{(g_j) \in GL(n, \mathbb{C})^{p+1}; g_p M_p g_p^{-1} \cdots g_0 M_0 g_0^{-1} = M_p \cdots M_0\}$ ,  $V_2$  is identified with  $L/Z(M_0) \times \cdots \times Z(M_p)$ . Denoting  $g_j = \exp(tX_j)$  with  $X_j \in M(n, \mathbb{C})$  and  $t \in \mathbb{R}$  with  $|t| \ll 1$  and defining  $A_j \in \text{End}(M(n, \mathbb{C}))$  by  $A_j X = M_j X M_j^{-1}$ , we can prove that the dimension of  $L$  equals the dimension of the kernel of the map

$$\gamma : M(n, \mathbb{C})^{p+1} \ni (X_0, \dots, X_p) \mapsto \sum_{j=0}^p A_p \cdots A_{j+1} (A_j - 1) X_j$$

by looking at the tangent space of  $L$  at the identity element because

$$\begin{aligned} & \exp(tX_p) M_p \exp(-tX_p) \cdots \exp(tX_0) M_0 (-tX_0) - M_p \cdots M_0 \\ &= t \left( \sum_{j=0}^p A_p \cdots A_{j+1} (A_j - 1) X_j \right) M_p \cdots M_0 + o(t). \end{aligned}$$

We have obtained in the proof of Lemma 11.11 that  $\text{codim } \ker \gamma = \dim \text{Im } \gamma = \dim \sum_{j=0}^p \text{Im}(A_j - 1) = \text{codim } \bigcap_{j=0}^p \ker({}^t A_j - 1)$ . We will see that  $\bigcap_{j=0}^p \ker({}^t A_j - 1)$  is identified with  $Z(\mathbf{M})$  and hence  $\text{codim } \ker \gamma = \text{codim } Z(\mathbf{M})$  and

$$\dim V_2 = \dim \ker \gamma - \sum_{j=0}^p \dim Z(M_j) = \sum_{j=0}^p \text{codim } Z(M_j) - \text{codim } Z(\mathbf{M}).$$

In general fix  $\mathbf{H} \in V_1$  and define  $A_j \in \text{End}(M(n, \mathbb{C}))$  by  $X \mapsto M_j X H_j^{-1}$  for  $j = 0, \dots, p$ . Note that  $A_p A_{p-1} \cdots A_0$  is the identity map. If we identify  $M(n, \mathbb{C})$  with its dual by the inner product trace  $XY$  for  $X, Y \in M(n, \mathbb{C})$ ,  ${}^t A_j$  are identified with the map  $Y \mapsto H_j^{-1} Y M_j$ , respectively.

Fix  $P_j \in GL(n, \mathbb{C})$  such that  $H_j = P_j M_j P_j^{-1}$ . Then

$$\begin{aligned} A_j(X) = X &\Leftrightarrow M_j X H_j^{-1} = X \Leftrightarrow M_j X = X P_j M_j P_j^{-1} \Leftrightarrow M_j X P_j = X P_j M_j, \\ {}^t A_j(X) = X &\Leftrightarrow H_j^{-1} X M_j = X \Leftrightarrow X M_j = P_j M_j P_j^{-1} X \Leftrightarrow P_j^{-1} X M_j = M_j P_j^{-1} X \end{aligned}$$

and  $\text{codim } \ker(A_j - 1) = \text{codim } Z(M_j)$  and  $\bigcap_{j=0}^p \ker({}^t A_j - 1) \simeq Z(\mathbf{M})$ .

Suppose  $\mathbf{M}$  is irreducible. Then  $\text{codim } Z(\mathbf{M}) = n^2 - 1$  and the inequality (11.47) follows from  $V_1 \subset V_2$ . Moreover suppose  $\sum_{j=0}^p \text{codim } Z(M_j) = 2n^2 - 2$ . Then Scott's lemma proves

$$\begin{aligned} 2n^2 - 2 &= \sum_{j=0}^p \text{codim } \ker(A_j - 1) \\ &\geq n^2 - \dim \bigcap_{j=0}^p \{X \in M(n, \mathbb{C}); M_j X = X H_j\} \\ &\quad + n^2 - \dim \bigcap_{j=0}^p \{X \in M(n, \mathbb{C}); H_j X = X M_j\}. \end{aligned}$$

Hence there exists a non-zero matrix  $X$  such that  $M_j X = X H_j$  ( $j = 0, \dots, p$ ) or  $H_j X = X M_j$  ( $j = 0, \dots, p$ ). If  $M_j X = X H_j$  (resp.  $H_j X = X M_j$ ) for  $j = 0, \dots, p$ ,  $\ker X$  (resp.  $\text{Im } X$ ) is  $M_j$ -stable for  $j = 0, \dots, p$  and hence  $X \in GL(n, \mathbb{C})$  because  $\mathbf{M}$  is irreducible. Thus we have  $V_1 = V_2$  and we get all the claims in the corollary.  $\square$

## 12. REDUCIBILITY

**12.1. Direct decompositions.** For a realizable  $(p+1)$ -tuple  $\mathbf{m} \in \mathcal{P}_{p+1}^{(n)}$ , Theorem 8.13 gives the universal Fuchsian differential operator  $P_{\mathbf{m}}(\lambda_{j,\nu}, g_i)$  with the Riemann scheme (6.15). Here  $g_1, \dots, g_N$  are accessory parameters and  $N = \text{Ridx } \mathbf{m}$ .

First suppose  $\mathbf{m}$  is basic. Choose positive numbers  $n'$ ,  $n''$ ,  $m'_{j,1}$  and  $m''_{j,1}$  such that

$$(12.1) \quad \begin{aligned} n &= n' + n'', \quad 0 < m'_{j,1} \leq n', \quad 0 < m''_{j,1} \leq n'', \\ m'_{0,1} + \dots + m'_{p,1} &\leq (p-1)n', \quad m''_{0,1} + \dots + m''_{p,1} \leq (p-1)n''. \end{aligned}$$

We choose other positive integers  $m'_{j,\nu}$  and  $m''_{j,\nu}$  so that  $\mathbf{m}' = (m'_{j,\nu})$  and  $\mathbf{m}'' = (m''_{j,\nu})$  are monotone tuples of partitions of  $n'$  and  $n''$ , respectively, and moreover

$$(12.2) \quad \mathbf{m} = \mathbf{m}' + \mathbf{m}''.$$

Theorem 8.6 shows that  $\mathbf{m}'$  and  $\mathbf{m}''$  are realizable. If  $\{\lambda_{j,\nu}\}$  satisfies the Fuchs relation

$$(12.3) \quad \sum_{j=0}^p \sum_{\nu=1}^{n_j} m'_{j,\nu} \lambda_{j,\nu} = n' - \frac{\text{idx } \mathbf{m}'}{2}$$

for the Riemann scheme  $\{[\lambda_{j,\nu}]_{(m'_{j,\nu})}\}$ , Theorem 6.19 shows that the operators

$$(12.4) \quad P_{\mathbf{m}''}(\lambda_{j,\nu} + m'_{j,\nu} - \delta_{j,0}(p-1)n', g_i'') \cdot P_{\mathbf{m}'}(\lambda_{j,\nu}, g_i')$$

has the Riemann scheme  $\{[\lambda_{j,\nu}]_{(m_{j,\nu})}\}$ . This shows that the equation  $P_{\mathbf{m}}(\lambda_{j,\nu}, g_i)u = 0$  is not irreducible when the parameters take the values corresponding to (12.4).

In this subsection, we study the condition

$$(12.5) \quad \text{Ridx } \mathbf{m} = \text{Ridx } \mathbf{m}' + \text{Ridx } \mathbf{m}''$$

for realizable tuples  $\mathbf{m}'$  and  $\mathbf{m}''$  with  $\mathbf{m} = \mathbf{m}' + \mathbf{m}''$ . Under this condition the Fuchs relation (12.3) assures that the universal operator is reducible for any values of accessory parameters.

**Definition 12.1** (direct decomposition). If realizable tuples  $\mathbf{m}$ ,  $\mathbf{m}'$  and  $\mathbf{m}''$  satisfy (12.2) and (12.5), we define that  $\mathbf{m}$  is the *direct sum* of  $\mathbf{m}'$  and  $\mathbf{m}''$  and call  $\mathbf{m} = \mathbf{m}' + \mathbf{m}''$  a *direct decomposition* of  $\mathbf{m}$  and express it as follows.

$$(12.6) \quad \mathbf{m} = \mathbf{m}' \oplus \mathbf{m}''.$$

**Theorem 12.2.** Let (12.6) be a direct decomposition of a realizable tuple  $\mathbf{m}$ .

i) Suppose  $\mathbf{m}$  is irreducibly realizable and  $\text{idx } \mathbf{m}'' > 0$ . Put  $\bar{\mathbf{m}}' = \text{gcd}(\mathbf{m}')^{-1} \mathbf{m}'$ . If  $\mathbf{m}'$  is indivisible or  $\text{idx } \mathbf{m} \leq 0$ , then

$$(12.7) \quad \alpha_{\mathbf{m}} = \alpha_{\mathbf{m}'} - 2 \frac{(\alpha_{\bar{\mathbf{m}}''} | \alpha_{\mathbf{m}'})}{(\alpha_{\bar{\mathbf{m}}''} | \alpha_{\bar{\mathbf{m}}''})} \alpha_{\bar{\mathbf{m}}''}$$

or  $\mathbf{m} = \mathbf{m}' \oplus \mathbf{m}''$  is isomorphic to one of the decompositions

$$(12.8) \quad \begin{aligned} 32, 32, 32, 221 &= 22, 22, 22, 220 \oplus 10, 10, 10, 001 \\ 322, 322, 2221 &= 222, 222, 2220 \oplus 100, 100, 0001 \\ 54, 3222, 22221 &= 44, 2222, 22220 \oplus 10, 1000, 00001 \\ 76, 544, 2222221 &= 66, 444, 2222220 \oplus 10, 100, 0000001 \end{aligned}$$

under the action of  $\widetilde{W}_{\infty}$ .



ii) Suppose  $\text{idx } \mathbf{m} \leq 0$  and  $\text{idx } \mathbf{m}' \leq 0$  and  $\text{idx } \mathbf{m}'' \leq 0$ . Then  $\mathbf{m} = \mathbf{m}' \oplus \mathbf{m}''$  or  $\mathbf{m} = \mathbf{m}'' \oplus \mathbf{m}'$  is transformed into one of the decompositions

$$(12.9) \quad \begin{aligned} \Sigma &= 11, 11, 11, 11 \quad 111, 111, 111 \quad 22, 1^4, 1^4 \quad 33, 222, 1^6 \\ m\Sigma &= k\Sigma \oplus \ell\Sigma \\ mm, mm, mm, m(m-1)1 &= kk, kk, kk, k(k-1)1 \oplus \ell\ell, \ell\ell, \ell\ell, \ell\ell 0 \\ mmm, mmm, mm(m-1)1 &= kkk, kkk, kkk, kk(k-1)1 \oplus \ell\ell\ell, \ell\ell\ell, \ell\ell\ell 0 \\ (2m)^2, m^4, mmm(m-1)1 &= (2k)^2, k^4, k^4, kkk(k-1)1 \oplus (2\ell)^2, \ell^4, \ell^4 0 \\ (3m)^2, (2m)^3, m^5(m-1)1 &= (3k)^2, (2k)^3, k^5(k-1)1 \oplus (3\ell)^2, (2\ell)^3, \ell^6 0 \end{aligned}$$

under the action of  $\widetilde{W}_\infty$ . Here  $m$ ,  $k$  and  $\ell$  are positive integers satisfying  $m = k + \ell$ . These are expressed by

$$(12.10) \quad \begin{aligned} m\tilde{D}_4 &= k\tilde{D}_4 \oplus \ell\tilde{D}_4, & m\tilde{E}_j &= k\tilde{E}_j \oplus \ell\tilde{E}_j \quad (j = 6, 7, 8), \\ D_4^{(m)} &= D_4^{(k)} \oplus \ell\tilde{D}_4, & E_j^{(m)} &= E_j^{(k)} \oplus \ell\tilde{E}_j \quad (j = 6, 7, 8). \end{aligned}$$

*Proof.* Put  $\mathbf{m}' = k\bar{\mathbf{m}}'$  and  $\mathbf{m}'' = \ell\bar{\mathbf{m}}''$  with indivisible  $\bar{\mathbf{m}}'$  and  $\bar{\mathbf{m}}''$ . First note that

$$(12.11) \quad (\alpha_{\mathbf{m}}|\alpha_{\mathbf{m}}) = (\alpha_{\mathbf{m}'}|\alpha_{\mathbf{m}'}) + 2(\alpha_{\mathbf{m}'}|\alpha_{\mathbf{m}''}) + (\alpha_{\mathbf{m}''}|\alpha_{\mathbf{m}''}).$$

ii) Using Lemma 12.3, we will prove the theorem. If  $\text{idx } \mathbf{m} = 0$ , then (12.11) and (12.12) show  $0 = (\alpha_{\mathbf{m}'}|\alpha_{\mathbf{m}''}) = k\ell(\alpha_{\bar{\mathbf{m}}'}|\alpha_{\bar{\mathbf{m}}''})$ , Lemma 12.3 proves  $\text{idx } \mathbf{m}' = 0$  and  $\bar{\mathbf{m}}' = \bar{\mathbf{m}}''$  and we have the theorem.

Suppose  $\text{idx } \mathbf{m} < 0$ .

If  $\text{idx } \mathbf{m}' < 0$  and  $\text{idx } \mathbf{m}'' < 0$ , we have  $\text{Pidx } \mathbf{m} = \text{Pidx } \mathbf{m}' + \text{Pidx } \mathbf{m}''$ , which implies  $(\alpha_{\mathbf{m}'}|\alpha_{\mathbf{m}''}) = -1$  and contradicts to Lemma 12.3.

Hence we may assume  $\text{idx } \mathbf{m}'' = 0$ .

Case:  $\text{idx } \mathbf{m}' < 0$ . It follows from (12.11) that  $2 - 2\text{Ridx } \mathbf{m} = 2 - 2\text{Ridx } \mathbf{m}' + 2\ell(\alpha_{\bar{\mathbf{m}}'}|\alpha_{\bar{\mathbf{m}}''})$ . Since  $\text{Ridx } \mathbf{m} = \text{Ridx } \mathbf{m}' + \ell$ , we have  $(\alpha_{\bar{\mathbf{m}}'}|\alpha_{\bar{\mathbf{m}}''}) = -1$  and the theorem follows from Lemma 12.3.

Case:  $\text{idx } \mathbf{m}' = 0$ . It follows from (12.11) that  $2 - 2\text{Ridx } \mathbf{m} = 2k\ell(\alpha_{\bar{\mathbf{m}}'}|\alpha_{\bar{\mathbf{m}}''})$ . Since the condition  $\text{Ridx } \mathbf{m} = k + \ell$  shows  $(\alpha_{\bar{\mathbf{m}}'}|\alpha_{\bar{\mathbf{m}}''}) = \frac{1}{k\ell} - \frac{1}{k} - \frac{1}{\ell}$  and we have  $(\alpha_{\bar{\mathbf{m}}'}|\alpha_{\bar{\mathbf{m}}''}) = -1$ . Hence the theorem also follows from Lemma 12.3.

i) First suppose  $\text{idx } \mathbf{m}' \neq 0$ . Note that  $\mathbf{m}$  and  $\mathbf{m}'$  are rigid if  $\text{idx } \mathbf{m}' > 0$ . We have  $\text{idx } \mathbf{m} = \text{idx } \mathbf{m}'$  and  $\text{idx } \mathbf{m} = (\alpha_{\mathbf{m}'} + \ell\alpha_{\bar{\mathbf{m}}''}|\alpha_{\mathbf{m}'} + \ell\alpha_{\bar{\mathbf{m}}''}) = \text{idx } \mathbf{m}' + 2\ell(\alpha_{\bar{\mathbf{m}}'}|\alpha_{\bar{\mathbf{m}}''}) + 2\ell^2$ , which implies (12.7).

Thus we may assume  $\text{idx } \mathbf{m} < 0$  and  $\text{idx } \mathbf{m}' = 0$ . If  $k = 1$ ,  $\text{idx } \mathbf{m} = \text{idx } \mathbf{m}' = 0$  and we have (12.7) as above. Hence we may moreover assume  $k \geq 2$ . Then (12.11) and the assumption imply  $2 - 2k = 2k\ell(\alpha_{\bar{\mathbf{m}}'}|\alpha_{\bar{\mathbf{m}}''}) + 2\ell^2$ , which means

$$-(\alpha_{\bar{\mathbf{m}}'}|\alpha_{\bar{\mathbf{m}}''}) = \frac{k-1+\ell^2}{k\ell}.$$

Here  $k$  and  $\ell$  are mutually prime and hence there exists a positive integer  $m$  with  $k = m\ell + 1$  and

$$-(\alpha_{\bar{\mathbf{m}}'}|\alpha_{\bar{\mathbf{m}}''}) = \frac{m+\ell}{m\ell+1} = \frac{1}{\ell + \frac{1}{m}} + \frac{1}{m + \frac{1}{\ell}} < 2.$$

Thus we have  $m = \ell = 1$ ,  $k = 2$  and  $(\alpha_{\bar{\mathbf{m}}'}|\alpha_{\bar{\mathbf{m}}''}) = -1$ . By the transformation of an element of  $\widetilde{W}_\infty$ , we may assume  $\bar{\mathbf{m}}' \in \mathcal{P}_{p+1}$  is a tuple in (12.16). Since  $(\alpha_{\bar{\mathbf{m}}'}|\alpha_{\bar{\mathbf{m}}''}) = -1$  and  $\alpha_{\bar{\mathbf{m}}''}$  is a positive real root, we have the theorem by a similar argument as in the proof of Lemma 12.3. Namely,  $m'_{p,n'_p} = 2$  and  $m'_{p,n'_p+1} = 0$  and we may assume  $m''_{j,n'_j+1} = 0$  for  $j = 0, \dots, p-1$  and  $m''_{p,n'_p+1} + m''_{p,n'_p+2} + \dots = 1$ , which proves the theorem in view of  $\alpha_{\mathbf{m}''} \in \Delta_+^{re}$ .  $\square$

**Lemma 12.3.** *Suppose  $\mathbf{m}$  and  $\mathbf{m}'$  are realizable and  $\text{idx } \mathbf{m} \leq 0$  and  $\text{idx } \mathbf{m}' \leq 0$ . Then*

$$(12.12) \quad (\alpha_{\mathbf{m}} | \alpha_{\mathbf{m}'}) \leq 0.$$

*If  $\mathbf{m}$  and  $\mathbf{m}'$  are basic and monotone,*

$$(12.13) \quad (\alpha_{\mathbf{m}} | w\alpha_{\mathbf{m}'}) \leq (\alpha_{\mathbf{m}} | \alpha_{\mathbf{m}'}) \quad (\forall w \in W_{\infty}).$$

*If  $(\alpha_{\mathbf{m}} | \alpha_{\mathbf{m}'}) = 0$  and  $\mathbf{m}$  and  $\mathbf{m}'$  are indivisible, then  $\text{idx } \mathbf{m} = 0$  and  $\mathbf{m} = \mathbf{m}'$ .*

*If  $(\alpha_{\mathbf{m}} | \alpha_{\mathbf{m}'}) = -1$ , then the pair is isomorphic to one of the pairs*

$$(12.14) \quad \begin{aligned} (D_4^{(k)}, \tilde{D}_4) &: ((kk, kk, kk, k(k-1)1), & (11, 11, 11, 110)) \\ (E_6^{(k)}, \tilde{E}_6) &: ((kkk, kkk, k(k-1)1), & (111, 111, 1110)) \\ (E_7^{(k)}, \tilde{E}_7) &: (((2k)^2, kkkk, kkk(k-1)1), & (22, 1111, 11110)) \\ (E_8^{(k)}, \tilde{E}_8) &: (((3k)^2, (2k)^3, kkkkk(k-1)1), & (33, 222, 111110)) \end{aligned}$$

*under the action of  $\widetilde{W}_{\infty}$ .*

*Proof.* We may assume that  $\mathbf{m}$  and  $\mathbf{m}'$  are indivisible. Under the transformation of the Weyl group, we may assume that  $\mathbf{m}$  is a basic monotone tuple in  $\mathcal{P}_{p+1}$ , namely,  $(\alpha_{\mathbf{m}} | \alpha_0) \leq 0$  and  $(\alpha_{\mathbf{m}} | \alpha_{j,\nu}) \leq 0$ .

If  $\mathbf{m}'$  is basic and monotone,  $w\alpha_{\mathbf{m}'} - \alpha_{\mathbf{m}'}$  is a sum of positive real roots, which proves (12.13).

Put  $\alpha_{\mathbf{m}} = n\alpha_0 + \sum n_{j,\nu}\alpha_{j,\nu}$  and  $\mathbf{m}' = n'_0\alpha_0 + \sum n'_{j,\nu}\alpha_{j,\nu}$ . Then

$$(12.15) \quad \begin{aligned} (\alpha_{\mathbf{m}} | \alpha_{\mathbf{m}'}) &= n'_0(\alpha_{\mathbf{m}} | \alpha_0) + \sum n'_{j,\nu}(\alpha_{\mathbf{m}} | \alpha_{j,\nu}), \\ (\alpha_{\mathbf{m}} | \alpha) &\leq 0 \quad (\forall \alpha \in \text{supp } \alpha_{\mathbf{m}}). \end{aligned}$$

Let  $k_j$  be the maximal positive integer satisfying  $m_{j,k_j} = m_{j,1}$  and put  $\Pi_0 = \{\alpha_0, \alpha_{j,\nu}; 1 \leq \nu < k_j, j = 0, \dots, p\}$ . Note that  $\Pi_0$  defines a classical root system if  $\text{idx } \mathbf{m} < 0$  (cf. Remark 9.12).

Suppose  $(\alpha_{\mathbf{m}} | \alpha_{\mathbf{m}'}) = 0$  and  $\mathbf{m} \in \mathcal{P}_{p+1}$ . Then  $m_{0,1} + \dots + m_{p,1} = (p-1) \text{ord } \mathbf{m}$  and  $\text{supp } \alpha_{\mathbf{m}'} \subset \Pi_0$  because  $(\alpha_{\mathbf{m}} | \alpha) = 0$  for  $\alpha \in \text{supp } \alpha_{\mathbf{m}'}$ . Hence it follows from  $\text{idx } \mathbf{m}' \leq 0$  that  $\text{idx } \mathbf{m} = 0$  and we may assume that  $\mathbf{m}$  is one of the tuples (12.16). Since  $\text{supp } \alpha_{\mathbf{m}'} \subset \text{supp } \alpha_{\mathbf{m}}$  and  $\text{idx } \mathbf{m}' \leq 0$ , we conclude that  $\mathbf{m}' = \mathbf{m}$ .

Lastly suppose  $(\alpha_{\mathbf{m}} | \alpha_{\mathbf{m}'}) = -1$ .

Case:  $\text{idx } \mathbf{m} = \text{idx } \mathbf{m}' = 0$ . If  $\mathbf{m}'$  is basic and monotone and  $\mathbf{m}' \neq \mathbf{m}$ , then it is easy to see that  $(\alpha_{\mathbf{m}} | \alpha_{\mathbf{m}'}) < -1$  (cf. Remark 9.1). Hence (12.13) assures  $\mathbf{m}' = w\mathbf{m}$  with a certain  $w \in W_{\infty}$  and therefore  $\text{supp } \mathbf{m} \subsetneq \text{supp } \mathbf{m}'$ . Moreover there exists  $j_0$  and  $L \geq k_{j_0}$  such that  $\text{supp } \mathbf{m}' = \text{supp } \mathbf{m} \cup \{\alpha_{j_0, k_{j_0}}, \alpha_{j_0, k_{j_0}+1}, \dots, \alpha_{j_0, L}\}$  and  $m_{j_0, k_{j_0}} = 1$  and  $m'_{j_0, k_{j_0}+1} = 1$ . Then by a transformation of an element of the Weyl group, we may assume  $L = k_{j_0}$  and  $\mathbf{m}' = r_{i_N} \cdots r_{i_1} r_{(j_0, k_{j_0})} \mathbf{m}$  with suitable  $i_{\nu}$  satisfying  $\alpha_{i_{\nu}} \in \text{supp } \mathbf{m}$  for  $\nu = 1, \dots, N$ . Applying  $r_{i_1} \cdots r_{i_N}$  to the pair  $(\mathbf{m}, \mathbf{m}')$ , we may assume  $\mathbf{m}' = r_{(j_0, k_{j_0})} \mathbf{m}$ . Hence the pair  $(\mathbf{m}, \mathbf{m}')$  is isomorphic to one of the pairs in the list (12.14) with  $k = 1$ .

Case:  $\text{idx } \mathbf{m} < 0$  and  $\text{idx } \mathbf{m}' \leq 0$ . There exists  $j_0$  such that  $\text{supp } \alpha_{\mathbf{m}'} \ni \alpha_{j_0, k_j}$ . Then the fact  $\text{idx}(\mathbf{m}, \mathbf{m}') = -1$  implies  $n'_{j_0, k_0} = 1$  and  $n'_{j, k_j} = 0$  for  $j \neq j_0$ . Let  $L$  be the maximal positive integer with  $n'_{j_0, L} \neq 0$ . Since  $(\alpha_{\mathbf{m}} | \alpha_{j_0, \nu}) = 0$  for  $k_0 + 1 \leq \nu \leq L$ , we may assume  $L = k_0$  by the transformation  $r_{(j_0, k_0+1)} \circ \dots \circ r_{(j_0, L)}$  if  $L > k_0$ . Since the Dynkin diagram corresponding to  $\Pi_0 \cup \{\alpha_{j_0, k_{j_0}}\}$  is classical or affine and  $\text{supp } \mathbf{m}'$  is contained in this set,  $\text{idx } \mathbf{m}' = 0$  and  $\mathbf{m}'$  is basic and we may assume that  $\mathbf{m}'$  is one of the tuples

$$(12.16) \quad 11, 11, 11, 11 \quad 111, 111, 111 \quad 22, 1111, 1111 \quad 33, 222, 111111$$

and  $j_0 = p$ . In particular  $m'_{p,1} = \cdots = m'_{p,k_p} = 1$  and  $m'_{p,k_p+1} = 0$ . It follows from  $(\alpha_{\mathbf{m}}|\alpha_{p,k_p}) = -1$  that there exists an integer  $L' \geq k_p + 1$  satisfying  $\text{supp } \mathbf{m} = \text{supp } \mathbf{m}' \cup \{\alpha_{p,\nu}; k_p \leq \nu < L'\}$  and  $m_{p,k_p} = m_{p,k_p-1} - 1$ . In particular,  $m_{j,\nu} = m_{j,1}$  for  $\nu = 1, \dots, k_j - \delta_{j,p}$  and  $j = 0, \dots, p$ . Since  $\sum_{j=0}^p m_{j,1} = (p-1) \text{ord } \mathbf{m}$ , there exists a positive integer  $k$  such that

$$m_{j,\nu} = \begin{cases} km'_{j,1} & (j = 0, \dots, p, \nu = 1, \dots, k_j - \delta_{j,p}), \\ km'_{p,1} - 1 & (j = p, \nu = k_p). \end{cases}$$

Hence  $m_{p,k_p+1} = 1$  and  $L' = k_p + 1$  and the pair  $(\mathbf{m}, \mathbf{m}')$  is one of the pairs in the list (12.14) with  $k > 1$ .  $\square$

*Remark 12.4.* Let  $k$  be an integer with  $k \geq 2$  and let  $P$  be a differential operator with the spectral type  $D_4^{(k)}, E_6^{(k)}, E_7^{(k)}$  or  $E_8^{(k)}$ . It follows from Theorem 6.19 and Theorem 8.13 that  $P$  is reducible for any values of accessory parameters when the characteristic exponents satisfy Fuchs relation with respect to the subtuple given in (12.14). For example, the Fuchsian differential operator  $P$  with the Riemann scheme

$$\left\{ \begin{array}{cccc} [\lambda_{0,1}]^{(k)} & [\lambda_{1,1}]^{(k)} & [\lambda_{2,1}]^{(k)} & [\lambda_{3,1}]^{(k)} \\ [\lambda_{0,2}]^{(k)} & [\lambda_{1,2}]^{(k)} & [\lambda_{2,2}]^{(k)} & [\lambda_{3,2}]^{(k-1)} \\ & & & \lambda_{3,2} + 2k - 2 \end{array} \right\}$$

is reducible.

**Example 12.5.** i) (generalized Jordan-Pochhammer) If  $\mathbf{m} = k\mathbf{m}' \oplus \ell\mathbf{m}''$  with a rigid tuples  $\mathbf{m}, \mathbf{m}'$  and  $\mathbf{m}''$  and positive integers  $k$  and  $\ell$  satisfying  $1 \leq k \leq \ell$ , we have

$$(12.17) \quad (\alpha_{\mathbf{m}'}|\alpha_{\mathbf{m}''}) = -\frac{k^2 + \ell^2 - 1}{k\ell} \in \mathbb{Z}.$$

For positive integers  $k$  and  $\ell$  satisfying  $1 \leq k \leq \ell$  and

$$(12.18) \quad p := \frac{k^2 + \ell^2 - 1}{k\ell} + 1 \in \mathbb{Z},$$

we have an example of direct decompositions

$$(12.19) \quad \begin{aligned} \overbrace{\ell k, \ell k, \dots, \ell k}^{p+1 \text{ partitions}} &= 0k, 0k, \dots, 0k \oplus \ell 0, \ell 0, \dots, \ell 0 \\ &= ((p-1)k - \ell)k, ((p-1)k - \ell)k, \dots, ((p-1)k - \ell)k \\ &\quad \oplus (2\ell - (p-1)k)0, (2\ell - (p-1)k)0, \dots, (2\ell - (p-1)k)0. \end{aligned}$$

Here  $p = 3 + \frac{(k-\ell)^2 - 1}{k\ell} \geq 2$  and the condition  $p = 2$  implies  $k = \ell = 1$  and the condition  $p = 3$  implies  $\ell = k + 1$ . If  $k = 1$ , then  $(\alpha_{\mathbf{m}'}|\alpha_{\mathbf{m}''}) = -\ell$  and we have an example corresponding to Jordan-Pochhammer equation:

$$(12.20) \quad \overbrace{\ell 1, \dots, \ell 1}^{\ell+2 \text{ partitions}} = 01, \dots, 01 \oplus \ell 0, \dots, \ell 0.$$

When  $\ell = k + 1$ , we have  $(\alpha_{\mathbf{m}'}|\alpha_{\mathbf{m}''}) = -2k$  and an example

$$(12.21) \quad \begin{aligned} &(k+1)k, (k+1)k, (k+1)k, (k+1)k \\ &= 0k, 0k, 0k, 0k \oplus (k+1)0, (k+1)0, (k+1)0, (k+1)0 \\ &= (k-1)k, (k-1)k, (k-1)k, (k-1)k \oplus 20, 20, 20, 20. \end{aligned}$$

We have another example

$$(12.22) \quad \begin{aligned} 83, 83, 83, 83, 83 &= 03, 03, 03, 03, 03 \oplus 80, 80, 80, 80, 80 \\ &= 13, 13, 13, 13, 13 \oplus 70, 70, 70, 70, 70 \end{aligned}$$

in the case  $(k, \ell) = (3, 8)$ , which is a special case where  $\ell = k^2 - 1$ ,  $p = k + 1$  and  $(\alpha_{\mathbf{m}'} | \alpha_{\mathbf{m}''}) = -k$ .

When  $p$  is odd, the equation (12.18) is equal to the Pell equation

$$(12.23) \quad y^2 - (m^2 - 1)x^2 = 1$$

by putting  $p - 1 = 2m$ ,  $x = \ell$  and  $y = m\ell - k$  and hence the reduction of the tuple of partition (12.19) by  $\partial_{\max}$  and its inverse give all the integer solutions of this Pell equation.

The tuple of partitions  $\ell k, \ell k, \dots, \ell k \in \mathcal{P}_{p+1}^{(\ell+k)}$  with (12.18) is called a *generalized Jordan-Pochhammer* tuple and denoted by  $P_{p+1, \ell+k}$ . In particular,  $P_{n+1, n}$  is simply denoted by  $P_n$ .

ii) We give an example of direct decompositions of a rigid tuple:

$$\begin{aligned} 3322, 532, 532 &= 0022, 202, 202 \oplus 3300, 330, 330 : 1 \\ &= 1122, 312, 312 \oplus 2200, 220, 220 : 1 \\ &= 0322, 232, 232 \oplus 3000, 300, 300 : 2 \\ &= 3302, 332, 332 \oplus 0020, 200, 200 : 2 \\ &= 1212, 321, 321 \oplus 2110, 211, 211 : 4 \\ &= 2211, 321, 312 \oplus 1111, 211, 220 : 2 \\ &= 2212, 421, 322 \oplus 1110, 111, 210 : 4 \\ &= 2222, 431, 422 \oplus 1100, 101, 110 : 2 \\ &= 2312, 422, 422 \oplus 1010, 110, 110 : 4 \\ &= 2322, 522, 432 \oplus 1000, 010, 100 : 4. \end{aligned}$$

They are all the direct decompositions of the tuple  $3322, 532, 532$  modulo obvious symmetries. Here we indicate the number of the decompositions of the same type.

**Corollary 12.6.** *Let  $\mathbf{m} \in \mathcal{P}$  be realizable. Put  $\mathbf{m} = \gcd(\mathbf{m})\bar{\mathbf{m}}$ . Then  $\mathbf{m}$  has no direct decomposition (12.6) if and only if*

$$(12.24) \quad \text{ord } \mathbf{m} = 1$$

or

$$(12.25) \quad \text{idx } \mathbf{m} = 0 \text{ and basic}$$

or

$$(12.26) \quad \text{idx } \mathbf{m} < 0 \text{ and } \bar{\mathbf{m}} \text{ is basic and } \mathbf{m} \text{ is not isomorphic to any one of tuples in Example 9.14 with } m > 1.$$

Moreover we have the following result.

**Proposition 12.7.** *The direct decomposition  $\mathbf{m} = \mathbf{m}' \oplus \mathbf{m}''$  is called rigid decomposition if  $\mathbf{m}$ ,  $\mathbf{m}'$  and  $\mathbf{m}''$  are rigid. If  $\mathbf{m} \in \mathcal{P}$  is rigid and  $\text{ord } \mathbf{m} > 1$ , there exists a rigid decomposition.*

*Proof.* We may assume that  $\mathbf{m}$  is monotone and there exist a non-negative integer  $p$  such that  $m_{j,2} \neq 0$  if and only if  $0 \leq j < p + 1$ . If  $\text{ord } \partial \mathbf{m} = 1$ , then we may assume  $\mathbf{m} = (p-1)1, (p-1)1, \dots, (p-1)1 \in \mathcal{P}_{p+1}^{(p)}$  and there exists a decomposition

$$(p-1)1, (p-1)1, \dots, (p-1)1 = 01, 10, \dots, 10 \oplus (p-1)0, (p-2)1, \dots, (p-2)1.$$

Suppose  $\text{ord } \partial \mathbf{m} > 1$ . Put  $d = \text{idx}(\mathbf{m}, \mathbf{1}) = m_{0,1} + \dots + m_{p,1} - (p-1) \cdot \text{ord } \mathbf{m} > 0$ .

The induction hypothesis assures the existence of a decomposition  $\partial \mathbf{m} = \bar{\mathbf{m}}' \oplus \bar{\mathbf{m}}''$  such that  $\bar{\mathbf{m}}'$  and  $\bar{\mathbf{m}}''$  are rigid. If  $\partial \bar{\mathbf{m}}'$  and  $\partial \bar{\mathbf{m}}''$  are well-defined, we have the decomposition  $\mathbf{m} = \partial^2 \mathbf{m} = \partial \bar{\mathbf{m}}' \oplus \partial \bar{\mathbf{m}}''$  and the proposition.

If  $\text{ord } \bar{\mathbf{m}}' > 1$ ,  $\partial \bar{\mathbf{m}}'$  is well-defined. Suppose  $\bar{\mathbf{m}}' = (\delta_{\nu, \ell_j})_{\substack{j=0, \dots, p \\ \nu=1, 2, \dots}}$ . Then

$$\begin{aligned} \text{idx}(\partial \mathbf{m}, \mathbf{1}) - \text{idx}(\partial \mathbf{m}, \bar{\mathbf{m}}') &= \sum_{j=0}^p ((m_{j,1} - d - (m_{j, \ell_j} - d\delta_{\ell_j, 1})) \\ &\geq -d \#\{j; \ell_j > 1, 0 \leq j \leq p\}. \end{aligned}$$

Since  $\text{idx}(\partial \mathbf{m}, \mathbf{1}) = -d$  and  $\text{idx}(\partial \mathbf{m}, \bar{\mathbf{m}}') = 1$ , we have  $d \#\{j; \ell_j > 1, 0 \leq j \leq p\} \geq d + 1$  and therefore  $\#\{j; \ell_j > 1, 0 \leq j \leq p\} \geq 2$ . Hence  $\partial \bar{\mathbf{m}}'$  is well-defined.  $\square$

*Remark 12.8.* The author's original construction of a differential operator with a given rigid Riemann scheme doesn't use the middle convolutions and additions but uses Proposition 12.7.

**Example 12.9.** We give direct decompositions of a rigid tuple:

$$\begin{aligned} (12.27) \quad 721, 3331, 22222 &= 200, 2000, 20000 \oplus 521, 1331, 02222 : 15 \\ &= 210, 1110, 11100 \oplus 511, 2221, 11122 : 10 \\ &= 310, 1111, 11110 \oplus 411, 2220, 11112 : 5 \end{aligned}$$

The following irreducibly realizable tuple has only two direct decompositions:

$$(12.28) \quad \begin{aligned} 44, 311111, 311111 &= 20, 200000, 200000 \oplus 24, 111111, 111111 \\ &= 02, 200000, 200000 \oplus 42, 111111, 111111 \end{aligned}$$

But it cannot be a direct sum of two irreducibly realizable tuples.

**12.2. Reduction of reducibility.** We give a necessary and sufficient condition so that a Fuchsian differential equation is irreducible, which follows from [Kz] and [DR, DR2]. Note that a Fuchsian differential equation is irreducible if and only if its monodromy is irreducible.

**Theorem 12.10.** *Retain the notation in §12.1. Suppose  $\mathbf{m}$  is monotone, realizable and  $\partial_{\max} \mathbf{m}$  is well-defined and*

$$(12.29) \quad d := m_{0,1} + \dots + m_{p,1} - (p-1) \text{ord } \mathbf{m} \geq 0.$$

Put  $P = P_{\mathbf{m}}$  (cf. (8.25)) and

$$(12.30) \quad \mu := \lambda_{0,1} + \lambda_{1,1} + \dots + \lambda_{p,1} - 1,$$

$$(12.31) \quad Q := \partial_{\max} P,$$

$$(12.32) \quad P^{\circ} := P|_{\lambda_{j,\nu} = \lambda_{j,\nu}^{\circ}, g_i = g_i^{\circ}}, \quad Q^{\circ} := Q|_{\lambda_{j,\nu} = \lambda_{j,\nu}^{\circ}, g_i = g_i^{\circ}}$$

with some complex numbers  $\lambda_{j,\nu}^{\circ}$  and  $g_i^{\circ}$  satisfying the Fuchs relation  $|\{\lambda_{\mathbf{m}}^{\circ}\}| = 0$ .

i) The Riemann scheme  $\{\tilde{\lambda}_{\bar{\mathbf{m}}}\}$  of  $Q$  is given by

$$(12.33) \quad \begin{cases} \tilde{m}_{j,\nu} = m_{j,\nu} - d\delta_{\nu,1}, \\ \tilde{\lambda}_{j,\nu} = \lambda_{j,\nu} + ((-1)^{\delta_{j,0}} - \delta_{\nu,1})\mu. \end{cases}$$

ii) Assume that the equation  $P^{\circ}u = 0$  is irreducible. If  $d > 0$ , then  $\mu \notin \mathbb{Z}$ . If the parameters given by  $\lambda_{j,\nu}^{\circ}$  and  $g_i^{\circ}$  are locally non-degenerate, the equation  $Q^{\circ}v = 0$  is irreducible and the parameters are locally non-degenerate.

iii) Assume that the equation  $Q^{\circ}v = 0$  is irreducible and the parameters given by  $\lambda_{j,\nu}^{\circ}$  and  $g_i^{\circ}$  are locally non-degenerate. Then the equation  $P^{\circ}v = 0$  is irreducible if and only if

$$(12.34) \quad \sum_{j=0}^p \lambda_{j,1+\delta_{j,j_0}(\nu_0-1)}^{\circ} \notin \mathbb{Z} \text{ for any } (j_0, \nu_0) \text{ satisfying } m_{j_0, \nu_0} > m_{j_0, 1} - d.$$

If the equation  $P^{\circ}v = 0$  is irreducible, the parameters are locally non-degenerate.

iv) Put  $\mathbf{m}(k) := \partial_{max}^k \mathbf{m}$  and  $P(k) = \partial_{max}^k P$ . Let  $K$  be a non-negative integer such that  $\text{ord } \mathbf{m}(0) > \text{ord } \mathbf{m}(1) > \cdots > \text{ord } \mathbf{m}(K)$  and  $\mathbf{m}(K)$  is fundamental. The operator  $P(k)$  is essentially the universal operator of type  $\mathbf{m}(k)$  but parametrized by  $\lambda_{j,\nu}$  and  $g_i$ . Put  $P(k)^o = P(k)|_{\lambda_{j,\nu} = \lambda_{j,\nu}^o}$ .

If the equation  $P^o u = 0$  is irreducible and the parameters are locally non-degenerate, so are  $P(k)^o u = 0$  for  $k = 1, \dots, K$ .

If the equation  $P^o u = 0$  is irreducible and locally non-degenerate, so is the equation  $P(K)^o u = 0$ .

Suppose the equation  $P(K)^o u = 0$  is irreducible and locally non-degenerate, which is always valid when  $\mathbf{m}$  is rigid. Then the equation  $P^o u = 0$  is irreducible if and only if the equation  $P(k)^o u = 0$  satisfy the condition (12.34) for  $k = 0, \dots, K-1$ . If the equation  $P^o u = 0$  is irreducible, it is locally non-degenerate.

*Proof.* The claim i) follows from Theorem 7.2 and the claims ii) and iii) follow from Lemma 7.3 and Corollary 11.10, which implies the claim iv).  $\square$

*Remark 12.11.* i) In the preceding theorem the equation  $P^o u = 0$  may not be locally non-degenerate even if it is irreducible. For example the equation satisfied by  ${}_3F_2$  is contained in the universal operator of type 111, 111, 111.

ii) It is also proved as follows that the irreducible differential equation with a rigid spectral type is locally non-degenerate.

The monodromy generators  $M_j$  of the equation with the Riemann scheme at  $x = c_j$  satisfy

$$\text{rank}(M'_j - e^{2\pi\sqrt{-1}\lambda_{j,1}}) \cdots (M'_j - e^{2\pi\sqrt{-1}\lambda_{j,k}}) \leq m_{j,k+1} + \cdots + m_{j,n_j} \quad (k = 1, \dots, n_j)$$

for  $j = 0, \dots, p$ . The equality in the above is clear when  $\lambda_{j,\nu} - \lambda_{j,\nu'} \notin \mathbb{Z}$  for  $1 \leq \nu < \nu' \leq n_j$  and hence the above is proved by the continuity for general  $\lambda_{j,\nu}$ . The rigidity index of  $\mathbf{M}$  is calculated by the dimension of the centralizer of  $M_j$  and it should be 2 if  $\mathbf{M}$  is irreducible and rigid, the equality in the above is valid (cf. [Kz], [O6]), which means the equation is locally non-degenerate.

iii) The same results as in Theorem 12.10 are also valid in the case of the Fuchsian system of Schlesinger canonical form (11.1) since the same proof works. A similar result is given by a different proof (cf. [CB]).

iv) Let  $(M_0, \dots, M_p)$  be a tuple of matrices in  $GL(n, \mathbb{C})$  with  $M_p M_{p-1} \cdots M_0 = I_n$ . Then  $(M_0, \dots, M_p)$  is called *rigid* if for any  $g_0, \dots, g_p \in GL(n, \mathbb{C})$  satisfying  $g_p M_p g_p^{-1} \cdots g_{p-1} M_{p-1} g_{p-1}^{-1} \cdots g_0 M_0 g_0^{-1} = I_n$ , there exists  $g \in GL(n, \mathbb{C})$  such that  $g_i M_i g_i^{-1} = g M_i g^{-1}$  for  $i = 0, \dots, p$ . The tuple  $(M_0, \dots, M_p)$  is called *irreducible* if no subspace  $V$  of  $\mathbb{C}^n$  satisfies  $\{0\} \subsetneq V \subsetneq \mathbb{C}^n$  and  $M_i V \subset V$  for  $i = 0, \dots, p$ . Choose  $\mathbf{m} \in \mathcal{P}_{p+1}^{(n)}$  and  $\{\mu_{j,\nu}\}$  such that  $L(\mathbf{m}; \mu_{j,1}, \dots, \mu_{j,n_j})$  are in the conjugacy classes containing  $M_j$ , respectively. Suppose  $(M_0, \dots, M_p)$  is irreducible and rigid. Then Katz [Kz] shows that  $\mathbf{m}$  is rigid and gives a construction of irreducible and rigid  $(M_0, \dots, M_p)$  for any rigid  $\mathbf{m}$  (cf. Remark 11.4 ii)). It is an open problem given by Katz [Kz] whether the monodromy generators  $M_j$  are realized by solutions of a single Fuchsian differential equations without an apparent singularity, whose affirmative answer is given by the following corollary.

**Corollary 12.12.** Let  $\mathbf{m} = (m_{j,\nu})_{\substack{0 \leq j \leq p \\ 1 \leq \nu \leq n_j}}$  be a rigid monotone  $(p+1)$ -tuple of partitions with  $\text{ord } \mathbf{m} > 1$ . Retain the notation in Definition 7.11.

i) Fix complex numbers  $\lambda_{j,\nu}$  for  $0 \leq j \leq p$  and  $1 \leq \nu_j$  such that it satisfies the Fuchs relation

$$(12.35) \quad \sum_{j=0}^p \sum_{\nu=1}^{n_j} m_{j,\nu} \lambda_{j,\nu} = \text{ord } \mathbf{m} - 1$$

The universal operator  $P_{\mathbf{m}}(\lambda)u = 0$  with the Riemann scheme (1.10) is irreducible if and only if the condition

$$(12.36) \quad \sum_{j=0}^p \lambda(k)_{j, \ell(k)_j + \delta_{j, j_o}(\nu_o - \ell(k)_j)} \notin \mathbb{Z}$$

for any  $(j_o, \nu_o)$  satisfying  $m(k)_{j_o, \nu_o} > m(k)_{j_o, \ell(k)_{j_o}} - d(k)$

is satisfied for  $k = 0, \dots, K-1$ .

ii) Define  $\tilde{\mu}(k)$  and  $\mu(k)_{j, \nu}$  for  $k = 0, \dots, K$  by

$$(12.37) \quad \mu(0)_{j, \nu} = \mu_{j, \nu} \quad (j = 0, \dots, p, \nu = 1, \dots, n_j),$$

$$(12.38) \quad \tilde{\mu}(k) = \prod_{j=0}^p \mu(k)_{j, \ell(k)_j},$$

$$(12.39) \quad \mu(k+1)_{j, \nu} = \mu(k)_{j, \nu} \cdot \tilde{\mu}(k)^{(-1)^{\delta_{j, 0} - \delta_{\nu, 1}}}.$$

Then there exists an irreducible tuple  $(M_0, \dots, M_p)$  of matrices satisfying

$$(12.40) \quad \begin{aligned} M_p \cdots M_0 &= I_n, \\ M_j &\sim L(m_{j,1}, \dots, m_{j, n_j}; \mu_{j,1}, \dots, \mu_{j, n_j}) \quad (j = 0, \dots, p) \end{aligned}$$

under the notation (6.33) if and only if

$$(12.41) \quad \prod_{j=0}^p \prod_{\nu=1}^{n_j} \mu_{j, \nu}^{m_{j, \nu}} = 1$$

and the condition

$$(12.42) \quad \prod_{j=0}^p \mu(k)_{j, \ell(k)_j + \delta_{j, j_o}(\nu_o - \ell(k)_j)} \neq 1$$

for any  $(j_o, \nu_o)$  satisfying  $m(k)_{j_o, \nu_o} > m(k)_{j_o, \ell(k)_{j_o}} - d(k)$

is satisfied for  $k = 0, \dots, K-1$ .

iii) Let  $(M_0, \dots, M_p)$  be an irreducible tuple of matrices satisfying (12.40). Then there uniquely exists a Fuchsian differential equation  $Pu = 0$  with  $p+1$  singular points  $c_0, \dots, c_p$  and its local independent solutions  $u_1, \dots, u_{\text{ord } \mathbf{m}}$  in a neighborhood of a non-singular point  $q$  such that the monodromy generators around the points  $c_j$  with respect to the solutions equal  $M_j$ , respectively, for  $j = 0, \dots, p$  (cf. (11.25)).

*Proof.* The claim i) is a direct consequence of Theorem 12.10 and the claim ii) is proved by Theorem 11.3 and Lemma 11.11 as in the case of the proof of Theorem 12.10 (cf. Remark 11.4 ii)).

iii) Since  $\text{gcd } \mathbf{m} = 1$ , we can choose  $\lambda_{j, \nu} \in \mathbb{C}$  such that  $e^{2\pi\sqrt{-1}\lambda_{j, \nu}} = \mu_{j, \nu}$  and  $\sum_{j, \nu} m_{j, \nu} \lambda_{j, \nu} = \text{ord } \mathbf{m} - 1$ . Then we have a universal operator  $P_{\mathbf{m}}(\lambda_{j, \nu})u = 0$  with the Riemann scheme (1.10). The irreducibility of  $(M_p, \dots, M_0)$  and Theorem 11.6 assure the claim.  $\square$

Now we state the condition (12.36) using the terminology of the Kac-Moody root system. Suppose  $\mathbf{m} \in \mathcal{P}$  is monotone and irreducibly realizable. Let  $\{\lambda_{\mathbf{m}}\}$  be the Riemann scheme of the universal operator  $P_{\mathbf{m}}$ . According to Remark 7.8 iii) we may relax the definition of  $\ell_{\text{max}}(\mathbf{m})$  as is given by (7.42) and then we may assume

$$(12.43) \quad v_k s_0 \cdots v_1 s_0 \Lambda(\lambda) \in W'_{\infty} \Lambda(\lambda(k)) \quad (k = 1, \dots, K)$$

under the notation in Definition 7.11 and (9.31). Then we have the following theorem.

**Theorem 12.13.** *Let  $\mathbf{m} = (m_{j,\nu})_{\substack{0 \leq j \leq p \\ 1 \leq \nu \leq n_j}}$  be an irreducibly realizable monotone tuple of partition in  $\mathcal{P}$ . Under the notation in Corollary 12.12 and §9.1, there uniquely exists a bijection*

$$(12.44) \quad \varpi : \Delta(\mathbf{m}) \xrightarrow{\sim} \left\{ (k, j_0, \nu_0) ; 0 \leq k < K, 0 \leq j_0 \leq p, 1 \leq \nu_0 \leq n_{j_0}, \right. \\ \left. \nu_0 \neq \ell(k)_{j_0} \text{ and } m(k)_{j_0, \nu_0} > m(k)_{j_0, \ell(k)_{j_0}} - d(k) \right\} \\ \cup \left\{ (k, 0, \ell(k)_0) ; 0 \leq k < K \right\}$$

such that

$$(12.45) \quad (\Lambda(\lambda)|\alpha) = \sum_{j=0}^p \lambda(k)_{j, \ell(k)_j + \delta_{j, j_0}(\nu_0 - \ell(k)_j)} \text{ when } \varpi(\alpha) = (k, j_0, \nu_0).$$

Moreover we have

$$(12.46) \quad (\alpha|\alpha_{\mathbf{m}}) = m(k)_{j_0, \nu_0} - m(k)_{j_0, \ell(k)_{j_0}} + d(k) \\ (\alpha \in \Delta(\mathbf{m}), (k, j_0, \nu_0) = \varpi(\alpha))$$

and if the universal equation  $P_{\mathbf{m}}(\lambda)u = 0$  is irreducible, we have

$$(12.47) \quad (\Lambda(\lambda)|\alpha) \notin \mathbb{Z} \text{ for any } \alpha \in \Delta(\mathbf{m}).$$

In particular, if  $\mathbf{m}$  is rigid and (12.47) is valid, the universal equation is irreducible.

*Proof.* Assume  $\text{ord } \mathbf{m} > 1$  and use the notation in Theorem 12.10. Since  $\tilde{\mathbf{m}}$  may not be monotone, we consider the monotone tuple  $\mathbf{m}' = s\tilde{\mathbf{m}}$  in  $S'_{\infty}\tilde{\mathbf{m}}$  (cf. Definition 6.11). First note that

$$d - m_{j,1} + m_{j,\nu} = (\alpha_0 + \alpha_{j,1} + \cdots + \alpha_{j,\nu-1}|\alpha_{\mathbf{m}}).$$

Let  $\bar{\nu}_j$  be the positive integers defined by

$$m_{j, \bar{\nu}_j + 1} \leq m_{j,1} - d < m_{j, \bar{\nu}_j}$$

for  $j = 0, \dots, p$ . Then

$$\alpha_{\mathbf{m}'} = v^{-1}\alpha_{\tilde{\mathbf{m}}} \text{ with } v := \left( \prod_{j=0}^p s_{j,1} \cdots s_{j, \bar{\nu}_j - 1} \right)$$

and  $w(\mathbf{m}) = s_0 v s_{\alpha_{\tilde{\mathbf{m}}}}$  and

$$\Delta(\mathbf{m}) = \Xi \cup s_0 v \Delta(\mathbf{m}'), \\ \Xi := \{ \alpha_0 \} \cup \bigcup_{\substack{0 \leq j \leq p \\ \nu_j \neq 1}} \{ \alpha_0 + \alpha_{j,1} + \cdots + \alpha_{j,\nu}; \nu = 1, \dots, \bar{\nu}_j - 1 \}.$$

Note that  $\ell(0) = (1, \dots, 1)$  and the condition  $m_{j_0, \nu_0} > m_{j_0, 1} - d(0)$  is valid if and only if  $\nu_0 \in \{1, \dots, \bar{\nu}_{j_0}\}$ . Since

$$\sum_{j=0}^p \lambda(0)_{j, 1 + \delta_{j, j_0}(\nu_0 - 1)} = (\Lambda(\lambda)|\alpha_0 + \alpha_{j_0, 1} + \cdots + \alpha_{j_0, \nu_0 - 1}) + 1,$$

we have

$$L(0) = \{ (\Lambda(\lambda)|\alpha) + 1 ; \alpha \in \Xi \}$$

by denoting

$$L(k) := \left\{ \sum_{j=0}^p \lambda(k)_{j, \ell(k)_j + \delta_{j, j_0}(\nu_0 - \ell(k)_j)} ; m(k)_{j_0, \nu_0} > m(k)_{j_0, \ell(k)_{j_0}} - d(k) \right\}.$$

Applying  $v^{-1}s_0$  to  $\mathbf{m}$  and  $\{\lambda_{\mathbf{m}}\}$ , they changes into  $\mathbf{m}'$  and  $\{\lambda'_{\mathbf{m}'}\}$ , respectively, such that  $\Lambda(\lambda') - v^{-1}s_0\Lambda(\lambda) \in \mathbb{C}\Lambda_0$ . Hence we obtain the corollary by the induction as in the proof of Corollary 12.12.  $\square$



*Remark 12.14.* Let  $\mathbf{m}$  be an irreducibly realizable monotone tuple in  $\mathcal{P}$ . Fix  $\alpha \in \Delta(\mathbf{m})$ . We have  $\alpha = \alpha_{\mathbf{m}'}$  with a rigid tuple  $\mathbf{m}' \in \mathcal{P}$  and

$$(12.48) \quad |\{\lambda_{\mathbf{m}'}\}| = (\Lambda(\lambda)|\alpha).$$

**Definition 12.15.** Define an *index*  $\text{idx}_{\mathbf{m}}(\ell(\lambda))$  of the non-zero linear form  $\ell(\lambda) = \sum_{j=0}^p \sum_{\nu=1}^{n_j} k_{j,\nu} \lambda_{j,\nu}$  of with  $k_{j,\nu} \in \mathbb{Z}_{\geq 0}$  as the positive integer  $d_i$  such that

$$(12.49) \quad \left\{ \sum_{j=0}^p \sum_{\nu=1}^{n_j} k_{j,\nu} \epsilon_{j,\nu}; \epsilon_{j,\nu} \in \mathbb{Z} \text{ and } \sum_{j=0}^p \sum_{\nu=1}^{n_j} m_{j,\nu} \epsilon_{j,\nu} = 0 \right\} = \mathbb{Z} d_i.$$

**Proposition 12.16.** For a rigid tuple  $\mathbf{m}$  in Corollary 12.12, define rigid tuples  $\mathbf{m}^{(1)}, \dots, \mathbf{m}^{(N)}$  with a non-negative integer  $N$  so that  $\Delta(\mathbf{m}) = \{\mathbf{m}^{(1)}, \dots, \mathbf{m}^{(N)}\}$  and put

$$(12.50) \quad \ell_i(\lambda) := \sum_{j=0}^p \sum_{\nu=1}^{n_j} m_{j,\nu}^{(i)} \lambda_{j,\nu} \quad (i = 1, \dots, N).$$

Here we note that Theorem 12.13 implies that  $P_{\mathbf{m}}(\lambda)$  is irreducible if and only if  $\ell_i(\lambda) \notin \mathbb{Z}$  for  $i = 1, \dots, n$ .

Fix a function  $\ell(\lambda)$  of  $\lambda_{j,\nu}$  such that  $\ell(\lambda) = \ell_i(\lambda) - r$  with  $i \in \{1, \dots, N\}$  and  $r \in \mathbb{Z}$ . Moreover fix generic complex numbers  $\lambda_{j,\nu} \in \mathbb{C}$  under the condition  $\ell(\lambda) = |\{\lambda_{\mathbf{m}}\}| = 0$  and a decomposition  $P_{\mathbf{m}}(\lambda) = P'P''$  such that  $P', P'' \in W(x)$ ,  $0 < n' := \text{ord } P' < n$  and the differential equation  $P'v = 0$  is irreducible. Then there exists an irreducibly realizable subtuple  $\mathbf{m}'$  of  $\mathbf{m}$  compatible to  $\ell(\lambda)$  such that the monodromy generators  $M'_j$  of the equation  $P'u = 0$  satisfies

$$\text{rank}(M_j - e^{2\pi\sqrt{-1}\lambda_{j,1}}) \cdots (M_j - e^{2\pi\sqrt{-1}\lambda_{j,k}}) \leq m'_{j,k+1} + \cdots + m'_{j,n_j} \quad (k = 1, \dots, n_j)$$

for  $j = 0, \dots, p$ . Here we define that the decomposition

$$(12.51) \quad \mathbf{m} = \mathbf{m}' + \mathbf{m}'' \quad (\mathbf{m}' \in \mathcal{P}_{p+1}^{(n')}, \mathbf{m}'' \in \mathcal{P}_{p+1}^{(n'')}, 0 < n' < n)$$

is compatible to  $\ell(\lambda)$  and that  $\mathbf{m}'$  is a subtuple of  $\mathbf{m}$  compatible to  $\ell(\lambda)$  if the following conditions are valid

$$(12.52) \quad |\{\lambda_{\mathbf{m}'}\}| \in \mathbb{Z}_{\leq 0} \quad \text{and} \quad |\{\lambda_{\mathbf{m}''}\}| \in \mathbb{Z},$$

$$(12.53) \quad \mathbf{m}' \text{ is realizable if there exists } (j, \nu) \text{ such that } m''_{j,\nu} = m_{j,\nu} > 0,$$

$$(12.54) \quad \mathbf{m}'' \text{ is realizable if there exists } (j, \nu) \text{ such that } m'_{j,\nu} = m_{j,\nu} > 0.$$

Here we note  $|\{\lambda_{\mathbf{m}'}\}| + |\{\lambda_{\mathbf{m}''}\}| = 1$  if  $\mathbf{m}'$  and  $\mathbf{m}''$  are rigid.

*Proof.* The equation  $P_{\mathbf{m}}(\lambda)u = 0$  is reducible since  $\ell(\lambda) = 0$ . We may assume  $\lambda_{j,\nu} - \lambda_{j,\nu'} \neq 0$  for  $1 \leq \nu < \nu' \leq n_j$  and  $j = 0, \dots, p$ . The solutions of the equation define the map  $\mathcal{F}$  given by (3.15) and the reducibility implies the existence of an irreducible submap  $\mathcal{F}'$  such that  $\mathcal{F}'(U) \subset \mathcal{F}(U)$  and  $0 < n' := \dim \mathcal{F}'(U) < n$ . Then  $\mathcal{F}'$  defines a irreducible Fuchsian differential equation  $P'v = 0$  which has regular singularities at  $x = c_0 = \infty, c_1, \dots, c_p$  and may have other apparent singularities  $c'_1, \dots, c'_q$ . Then the characteristic exponents of  $P'$  at the singular points are as follows.

There exists a decomposition  $\mathbf{m} = \mathbf{m}' + \mathbf{m}''$  such that  $\mathbf{m}' \in \mathcal{P}^{(n')}$  and  $\mathbf{m}'' \in \mathcal{P}^{(n'')}$  with  $n'' := n - n'$ . The sets of characteristic exponents of  $P'$  at  $x = c_j$  are  $\{\lambda'_{j,\nu,i}; i = 1, \dots, m'_{j,\nu}, \nu = 1, \dots, n\}$  which satisfy

$$\lambda'_{j,\nu,i} - \lambda_{j,\nu} \in \{0, 1, \dots, m_{j,\nu} - 1\} \quad \text{and} \quad \lambda'_{j,\nu,1} < \lambda'_{j,\nu,2} < \cdots < \lambda'_{j,\nu,m'_{j,\nu}}$$

for  $j = 0, \dots, p$ . The sets of characteristic exponents at  $x = c'_j$  are  $\{\mu_{j,1}, \dots, \mu_{j,n'}\}$ , which satisfy  $\mu_{j,i} \in \mathbb{Z}$  and  $0 \leq \mu_{j,1} < \cdots < \mu_{j,n'}$  for  $j = 1, \dots, q$ . Then Remark 6.17 ii) says that the Fuchs relation of the equation  $P'v = 0$  implies  $|\{\lambda_{\mathbf{m}'}\}| \in \mathbb{Z}_{\leq 0}$ .

Note that there exists a Fuchsian differential operator  $P'' \in W(x)$  such that  $P = P''P'$ . If there exists  $j_o$  and  $\nu_o$  such that  $m'_{j_o, n_o} = 0$ , namely,  $m''_{j_o, \nu_o} = m_{j_o, \nu_o} > 0$ , the exponents of the monodromy generators of the solution  $P'v = 0$  are generic and hence  $\mathbf{m}'$  should be realizable. The same claim is also true for the tuple  $\mathbf{m}''$ . Hence we have the proposition.  $\square$

**Example 12.17.** i) The reduction of the universal operator with the spectral type 11, 11, 11 which is given by Theorem 12.10 is

$$(12.55) \quad \left\{ \begin{array}{ccc} x = \infty & 0 & 1 \\ \lambda_{0,1} & \lambda_{1,1} & \lambda_{2,1} \\ \lambda_{0,2} & \lambda_{1,2} & \lambda_{2,2} \end{array} \right\} \quad \left( \sum \lambda_{j,\nu} = 1 \right)$$

$$\longrightarrow \left\{ \begin{array}{ccc} x = \infty & 0 & 1 \\ 2\lambda_{0,2} + \lambda_{1,1} + \lambda_{2,1} & -\lambda_{0,2} - \lambda_{2,2} & -\lambda_{0,2} - \lambda_{1,2} \end{array} \right\}$$

because  $\mu = \lambda_{0,1} + \lambda_{1,1} + \lambda_{2,1} - 1 = -\lambda_{0,2} - \lambda_{1,2} - \lambda_{2,2}$ . Hence the necessary and sufficient condition for the irreducibility of the universal operator given by (12.34) is

$$\left\{ \begin{array}{l} \lambda_{0,1} + \lambda_{1,1} + \lambda_{2,1} \notin \mathbb{Z}, \\ \lambda_{0,2} + \lambda_{1,1} + \lambda_{2,1} \notin \mathbb{Z}, \\ \lambda_{0,1} + \lambda_{1,2} + \lambda_{2,1} \notin \mathbb{Z}, \\ \lambda_{0,1} + \lambda_{1,1} + \lambda_{2,2} \notin \mathbb{Z}, \end{array} \right.$$

which is equivalent to

$$(12.56) \quad \lambda_{0,i} + \lambda_{1,1} + \lambda_{2,j} \notin \mathbb{Z} \quad \text{for } i = 1, 2 \text{ and } j = 1, 2.$$

The rigid tuple  $\mathbf{m} = 11, 11, 11$  corresponds to the real root  $\alpha_{\mathbf{m}} = 2\alpha_0 + \alpha_{0,1} + \alpha_{1,1} + \alpha_{2,1}$  under the notation in §9.1. Then  $\Delta(\mathbf{m}) = \{\alpha_0, \alpha_0 + \alpha_{j,1}; j = 0, 1, 2\}$  and  $(\Lambda|\alpha_0) = \lambda_{0,1} + \lambda_{1,1} + \lambda_{2,1}$  and  $(\Lambda|\alpha_0 + \alpha_{0,1}) = \lambda_{0,2} + \lambda_{1,1} + \lambda_{2,1}$ , etc. under the notation in Theorem 12.13.

The Riemann scheme for the Gauss hypergeometric series  ${}_2F_1(a, b, c; z)$  is given

$$\text{by } \left\{ \begin{array}{ccc} x = \infty & 0 & 1 \\ a & 0 & 0 \\ b & 1 - c & c - a - b \end{array} \right\} \text{ and therefore the condition for the irreducibility}$$

is

$$(12.57) \quad a \notin \mathbb{Z}, b \notin \mathbb{Z}, c - b \notin \mathbb{Z} \text{ and } c - a \notin \mathbb{Z}.$$

ii) The reduction of the Riemann scheme for the equation corresponding to  ${}_3F_2(\alpha_1, \alpha_2, \alpha_3, \beta_1, \beta_2; x)$  is

$$(12.58) \quad \left\{ \begin{array}{ccc} x = \infty & 0 & 1 \\ \alpha_1 & 0 & [0]_{(2)} \\ \alpha_2 & 1 - \beta_1 & -\beta_3 \\ \alpha_3 & 1 - \beta_2 & \end{array} \right\} \quad \left( \sum_{i=1}^3 \alpha_i = \sum_{i=1}^3 \beta_i \right)$$

$$\longrightarrow \left\{ \begin{array}{ccc} x = \infty & 0 & 1 \\ \alpha_2 - \alpha_1 + 1 & \alpha_1 - \beta_1 & 0 \\ \alpha_3 - \alpha_1 + 1 & \alpha_1 - \beta_2 & \alpha_1 - \beta_3 - 1 \end{array} \right\}$$

with  $\mu = \alpha_1 - 1$ . Hence Theorem 12.10 says that the condition for the irreducibility equals

$$\left\{ \begin{array}{l} \alpha_i \notin \mathbb{Z} \quad (i = 1, 2, 3), \\ \alpha_1 - \beta_j \notin \mathbb{Z} \quad (j = 1, 2) \end{array} \right.$$

together with

$$\alpha_i - \beta_j \notin \mathbb{Z} \quad (i = 2, 3, j = 1, 2).$$

Here the second condition follows from i). Hence the condition for the irreducibility is

$$(12.59) \quad \alpha_i \notin \mathbb{Z} \text{ and } \alpha_i - \beta_j \notin \mathbb{Z} \quad (i = 1, 2, 3, j = 1, 2).$$

iii) The reduction of the even family is as follows:

$$\left\{ \begin{array}{ccc} x = \infty & 0 & 1 \\ \alpha_1 & [0]_{(2)} & [0]_{(2)} \\ \alpha_2 & 1 - \beta_1 & [-\beta_3]_{(2)} \\ \alpha_3 & 1 - \beta_2 & \\ \alpha_4 & & \end{array} \right\} \longrightarrow \left\{ \begin{array}{ccc} x = \infty & 0 & 1 \\ \alpha_2 - \alpha_1 + 1 & 0 & 0 \\ \alpha_3 - \alpha_1 + 1 & \alpha_1 - \beta_1 & [\alpha_1 - \beta_3 - 1]_{(2)} \\ \alpha_4 - \alpha_1 + 1 & \alpha_1 - \beta_2 & \end{array} \right\}$$

$$\xrightarrow{(x-1)^{-\alpha_1+\beta_3+1}} \left\{ \begin{array}{ccc} x = \infty & 0 & 1 \\ \alpha_2 - \beta_3 & 0 & -\alpha_1 + \beta_3 + 1 \\ \alpha_3 - \beta_3 & \alpha_1 - \beta_1 & [0]_{(2)} \\ \alpha_4 - \beta_3 & \alpha_1 - \beta_2 & \end{array} \right\}.$$

Hence the condition for the irreducibility is

$$\begin{cases} \alpha_i \notin \mathbb{Z} & (i = 1, 2, 3, 4), \\ \alpha_1 - \beta_3 \notin \mathbb{Z} \end{cases}$$

together with

$$\begin{cases} \alpha_i - \beta_3 \notin \mathbb{Z} & (i = 2, 3, 4). \\ \alpha_1 + \alpha_i - \beta_j - \beta_3 \notin \mathbb{Z} & (i = 2, 3, 4, j = 1, 2) \end{cases}$$

by the result in ii). Thus the condition is

$$(12.60) \quad \alpha_i \notin \mathbb{Z}, \alpha_i - \beta_3 \notin \mathbb{Z} \text{ and } \alpha_1 + \alpha_k - \beta_j - \beta_3 \notin \mathbb{Z} \\ (i = 1, 2, 3, 4, j = 1, 2, k = 2, 3, 4).$$

Hence the condition for the irreducibility for the equation with the Riemann scheme

$$(12.61) \quad \left\{ \begin{array}{ccc} \lambda_{0,1} & [\lambda_{1,1}]_{(2)} & [\lambda_{2,1}]_{(2)} \\ \lambda_{0,2} & \lambda_{1,2} & [\lambda_{2,2}]_{(2)} \\ \lambda_{0,3} & \lambda_{1,3} & \\ \lambda_{0,4} & & \end{array} \right\}$$

of type 1111, 211, 22 is

$$(12.62) \quad \begin{cases} \lambda_{0,\nu} + \lambda_{1,1} + \lambda_{2,k} \notin \mathbb{Z} & (\nu = 1, 2, 3, 4, k = 1, 2) \\ \lambda_{0,\nu} + \lambda_{0,\nu'} + \lambda_{1,1} + \lambda_{1,2} + \lambda_{2,1} + \lambda_{2,2} \notin \mathbb{Z} & (1 \leq \nu < \nu' \leq 4). \end{cases}$$

This condition corresponds to the rigid decompositions

$$(12.63) \quad 1^4, 21^2, 2^2 = 1, 10, 1 \oplus 1^3, 11^2, 21 = 1^2, 11, 1^2 \oplus 1^2, 11, 1^2,$$

which are also important in the connection formula.

iv) (generalized Jordan-Pochhammer) The reduction of the universal operator of the rigid spectral type 32, 32, 32, 32 is as follows:

$$\begin{aligned} & \left\{ \begin{array}{cccc} [\lambda_{0,1}]_{(3)} & [\lambda_{1,1}]_{(3)} & [\lambda_{2,1}]_{(3)} & [\lambda_{3,1}]_{(3)} \\ [\lambda_{0,2}]_{(2)} & [\lambda_{1,2}]_{(2)} & [\lambda_{2,2}]_{(2)} & [\lambda_{3,2}]_{(2)} \end{array} \right\} \quad \left( 3 \sum_{j=0}^3 \lambda_{j,1} + 2 \sum_{j=0}^3 \lambda_{j,2} = 4 \right) \\ & \longrightarrow \left\{ \begin{array}{cccc} \lambda_{0,1} - 2\mu & \lambda_{1,1} & \lambda_{2,1} & \lambda_{3,1} \\ [\lambda_{0,2} - \mu]_{(2)} & [\lambda_{1,2} + \mu]_{(2)} & [\lambda_{2,2} + \mu]_{(2)} & [\lambda_{3,2} + \mu]_{(2)} \end{array} \right\} \end{aligned}$$

with  $\mu = \lambda_{0,1} + \lambda_{1,1} + \lambda_{2,1} + \lambda_{3,1} - 1$ . Hence the condition for the irreducibility is

$$(12.64) \quad \begin{cases} \sum_{j=0}^3 \lambda_{j,1+\delta_{j,k}} \notin \mathbb{Z} & (k = 0, 1, 2, 3, 4), \\ \sum_{j=0}^3 (1 + \delta_{j,k}) \lambda_{j,1} + \sum_{j=0}^3 (1 - \delta_{j,k}) \lambda_{j,2} \notin \mathbb{Z} & (k = 0, 1, 2, 3, 4). \end{cases}$$

Note that under the notation defined by Definition 12.15 we have

$$(12.65) \quad \text{idx}_{\mathbf{m}}(\lambda_{0,1} + \lambda_{1,1} + \lambda_{2,1} + \lambda_{3,1}) = 2$$

and the index of any other linear form in (12.64) is 1.

In general the universal operator with the Riemann scheme

$$(12.66) \quad \left\{ \begin{array}{cccc} [\lambda_{0,1}]_{(k)} & [\lambda_{1,1}]_{(k)} & [\lambda_{2,1}]_{(k)} & [\lambda_{3,1}]_{(k)} \\ [\lambda_{0,2}]_{(k-1)} & [\lambda_{1,2}]_{(k-1)} & [\lambda_{2,2}]_{(k-1)} & [\lambda_{3,2}]_{(k-1)} \end{array} \right\} \\ (k \sum_{j=0}^3 \lambda_{j,1} + (k-1) \sum_{j=0}^3 \lambda_{j,2} = 2k)$$

is irreducible if and only if

$$(12.67) \quad \left\{ \begin{array}{l} \sum_{j=0}^3 (\nu - \delta_{j,k}) \lambda_{j,1} + \sum_{j=0}^3 (\nu - 1 + \delta_{j,k}) \lambda_{j,1} \notin \mathbb{Z} \quad (k = 0, 1, 2, 3, 4), \\ \sum_{j=0}^3 (\nu' + \delta_{j,k}) \lambda_{j,1} + \sum_{j=0}^3 (\nu' - \delta_{j,k}) \lambda_{j,2} \notin \mathbb{Z} \quad (k = 0, 1, 2, 3, 4), \end{array} \right.$$

for any integers  $\nu$  and  $\nu'$  satisfying  $1 \leq 2\nu \leq k$  and  $1 \leq 2\nu' \leq k-1$ .

The rigid decomposition

$$(12.68) \quad 65, 65, 65, 65 = 12, 21, 21, 21 \oplus 53, 44, 44, 44$$

gives an example of the decomposition  $\mathbf{m} = \mathbf{m}' \oplus \mathbf{m}''$  with  $\text{supp } \alpha_{\mathbf{m}} = \text{supp } \alpha_{\mathbf{m}'} = \text{supp } \alpha_{\mathbf{m}''}$ .

v) The rigid Fuchsian differential equation with the Riemann scheme

$$\left( \begin{array}{ccccc} x=0 & 1 & c_3 & c_4 & \infty \\ [0]_{(9)} & [0]_{(9)} & [0]_{(9)} & [0]_{(9)} & [e_0]_{(8)} \\ [a]_{(3)} & [b]_{(3)} & [c]_{(3)} & [d]_{(3)} & [e_1]_{(3)} \\ & & & & e_2 \end{array} \right)$$

is reducible when

$$a + b + c + d + 3e_0 + e_1 \in \mathbb{Z},$$

which is equivalent to  $\frac{1}{3}(e_0 - e_2 - 1) \in \mathbb{Z}$  under the Fuchs relation. At the generic point of this reducible condition, the spectral types of the decomposition in the Grothendieck group of the monodromy is

$$93, 93, 93, 93, 831 = 31, 31, 31, 31, 211 + 31, 31, 31, 31, 310 + 31, 31, 31, 31, 310.$$

Note that the following reduction of the spectral types

$$\begin{array}{l} 93, 93, 93, 93, 831 \rightarrow 13, 13, 13, 13, 031 \rightarrow 10, 10, 10, 10, 001 \\ 31, 31, 31, 31, 211 \rightarrow 11, 11, 11, 11, 011 \\ 31, 31, 31, 31, 310 \rightarrow 01, 01, 01, 01, 010 \end{array}$$

and  $\text{idx}(31, 31, 31, 31, 211) = -2$ .

### 13. SHIFT OPERATORS

In this section we study an integer shift of spectral parameters  $\lambda_{j,\nu}$  of the Fuchsian equation  $P_{\mathbf{m}}(\lambda)u = 0$ . Here  $P_{\mathbf{m}}(\lambda)$  is the universal operator (cf. Theorem 8.13) corresponding to the spectral type  $\mathbf{m} = (m_{j,\nu})_{\substack{j=0,\dots,p \\ \nu=1,\dots,n_j}}$ . For simplicity we assume that  $\mathbf{m}$  is rigid in this section.

**13.1. Construction of shift operators and recurrence relations.** First we construct shift operators for general shifts.

**Definition 13.1.** For  $\mathbf{m} = (m_{j,\nu})_{\substack{j=0,\dots,p \\ \nu=1,\dots,n_j}} \in \mathcal{P}_{p+1}^{(n)}$ , a set of integers  $(\epsilon_{j,\nu})_{\substack{j=0,\dots,p \\ \nu=1,\dots,n_j}}$  parametrized by  $j$  and  $\nu$  is called a *shift compatible to  $\mathbf{m}$*  if

$$(13.1) \quad \sum_{j=0}^p \sum_{\nu=1}^{n_j} \epsilon_{j,\nu} m_{j,\nu} = 0.$$

**Theorem 13.2** (shift operator). *Fix a shift  $(\epsilon_{j,\nu})$  compatible to  $\mathbf{m} \in \mathcal{P}_{p+1}^{(n)}$ . Then there is a shift operator  $R_{\mathbf{m}}(\epsilon, \lambda) \in W[x] \otimes \mathbb{C}[\lambda_{j,\nu}]$  which gives a homomorphism of the equation  $P_{\mathbf{m}}(\lambda')v = 0$  to  $P_{\mathbf{m}}(\lambda)u = 0$  defined by  $v = R_{\mathbf{m}}(\epsilon, \lambda)u$ . Here the Riemann scheme of  $P_{\mathbf{m}}(\lambda)$  is  $\{\lambda_{\mathbf{m}}\} = \{[\lambda_{j,\nu}]_{(m_{j,\nu})}\}_{\substack{j=0,\dots,p \\ \nu=1,\dots,n_j}}$  and that of  $P_{\mathbf{m}}(\lambda')$  is  $\{\lambda'_{\mathbf{m}}\}$  defined by  $\lambda'_{j,\nu} = \lambda_{j,\nu} + \epsilon_{j,\nu}$ . Moreover we may assume  $\text{ord } R_{\mathbf{m}}(\epsilon, \lambda) < \text{ord } \mathbf{m}$  and  $R_{\mathbf{m}}(\epsilon, \lambda)$  never vanishes as a function of  $\lambda$  and then  $R_{\mathbf{m}}(\epsilon, \lambda)$  is uniquely determined up to a constant multiple.*

Putting

$$(13.2) \quad \tau = (\tau_{j,\nu})_{\substack{0 \leq j \leq p \\ 1 \leq \nu \leq n_j}} \quad \text{with} \quad \tau_{j,\nu} := (2 + (p-1)n)\delta_{j,0} - m_{j,\nu}$$

and  $d = \text{ord } R_{\mathbf{m}}(\epsilon, \lambda)$ , we have

$$(13.3) \quad P_{\mathbf{m}}(\lambda + \epsilon)R_{\mathbf{m}}(\epsilon, \lambda) = (-1)^d R_{\mathbf{m}}(\epsilon, \tau - \lambda - \epsilon)^* P_{\mathbf{m}}(\lambda)$$

under the notation in Theorem 6.19 ii).

*Proof.* We will prove the theorem by the induction on  $\text{ord } \mathbf{m}$ . The theorem is clear if  $\text{ord } \mathbf{m} = 1$ .

We may assume that  $\mathbf{m}$  is monotone. Then the reduction  $\{\tilde{\lambda}_{\mathbf{m}}\}$  of the Riemann scheme is defined by (12.33). Hence putting

$$(13.4) \quad \begin{cases} \tilde{\epsilon}_1 = \epsilon_{0,1} + \dots + \epsilon_{p,1}, \\ \tilde{\epsilon}_{j,\nu} = \epsilon_{j,\nu} + ((-1)^{\delta_{j,0}} - \delta_{\nu,1})\tilde{\epsilon}_1 \quad (j = 0, \dots, p, \nu = 1, \dots, n_j), \end{cases}$$

there is a shift operator  $R(\tilde{\epsilon}, \tilde{\lambda})$  of the equation  $P_{\tilde{\mathbf{m}}}(\tilde{\lambda}')\tilde{v} = 0$  to  $P_{\tilde{\mathbf{m}}}(\tilde{\lambda})\tilde{u} = 0$  defined by  $\tilde{v} = R(\tilde{\epsilon}, \tilde{\lambda})\tilde{u}$ . Note that

$$\begin{aligned} P_{\tilde{\mathbf{m}}}(\tilde{\lambda}) &= \partial_{\max} P_{\mathbf{m}}(\lambda) = \text{Ad}\left(\prod_{j=1}^p (x - c_j)^{\lambda_{j,1}}\right) \prod_{j=1}^p (x - c_j)^{m_{j,1}-d} \partial^{-d} \text{Ad}(\partial^{-\mu}) \\ &\quad \prod_{j=1}^p (x - c_j)^{-m_{j,1}} \text{Ad}\left(\prod_{j=1}^p (x - c_j)^{-\lambda_{j,1}}\right) P_{\mathbf{m}}(\lambda), \\ P_{\tilde{\mathbf{m}}}(\tilde{\lambda}') &= \partial_{\max} P_{\mathbf{m}}(\lambda') = \text{Ad}\left(\prod_{j=1}^p (x - c_j)^{\lambda'_{j,1}}\right) \prod_{j=1}^p (x - c_j)^{m_{j,1}-d} \partial^{-d} \text{Ad}(\partial^{-\mu'}) \\ &\quad \prod_{j=1}^p (x - c_j)^{-m_{j,1}} \text{Ad}\left(\prod_{j=1}^p (x - c_j)^{-\lambda'_{j,1}}\right) P_{\mathbf{m}}(\lambda'). \end{aligned}$$

Suppose  $\lambda_{j,\nu}$  are generic. Let  $u(x)$  be a local solution of  $P_{\mathbf{m}}(\lambda)u = 0$  at  $x = c_1$  corresponding to a characteristic exponent different from  $\lambda_{1,1}$ . Then

$$\tilde{u}(x) := \prod_{j=1}^p (x - c_j)^{\lambda_{j,1}} \partial^{-\mu} \prod_{j=1}^p (x - c_j)^{-\lambda_{j,1}} u(x)$$

satisfies  $P_{\mathbf{m}}(\tilde{\lambda})\tilde{u}(x) = 0$ . Putting

$$\begin{aligned}\tilde{v}(x) &:= R(\tilde{\epsilon}, \tilde{\lambda})\tilde{u}(x), \\ v(x) &:= \prod_{j=1}^p (x - c_j)^{\lambda'_{j,1}} \partial^{\mu'} \prod_{j=1}^p (x - c_j)^{\lambda'_{j,1}} \tilde{v}(x), \\ \tilde{R}(\tilde{\epsilon}, \tilde{\lambda}) &:= \text{Ad}\left(\prod_{j=1}^p (x - c_j)^{\lambda_{j,1}}\right) R(\tilde{\epsilon}, \tilde{\lambda})\end{aligned}$$

we have  $P_{\mathbf{m}}(\tilde{\lambda}')\tilde{u}(x) = 0$ ,  $P_{\mathbf{m}}(\lambda')v(x) = 0$  and

$$\prod_{j=1}^p (x - c_j)^{\epsilon_{j,1}} \partial^{-\mu'} \prod_{j=1}^p (x - c_j)^{-\lambda'_{j,1}} v(x) = \tilde{R}(\tilde{\epsilon}, \tilde{\lambda}) \partial^{-\mu} \prod_{j=1}^p (x - c_j)^{-\lambda_{j,1}} u(x).$$

In general, if

$$(13.5) \quad S_2 \prod_{j=1}^p (x - c_j)^{\epsilon_{j,1}} \partial^{-\mu'} \prod_{j=1}^p (x - c_j)^{-\lambda'_{j,1}} v(x) = S_1 \partial^{-\mu} \prod_{j=1}^p (x - c_j)^{-\lambda_{j,1}} u(x)$$

with  $S_1, S_2 \in W[x]$ , we have

$$(13.6) \quad R_2 v(x) = R_1 u(x)$$

by putting

$$(13.7) \quad \begin{aligned}R_1 &= \prod_{j=1}^p (x - c_j)^{\lambda_{j,\nu} + k_{1,j}} \partial^{\mu + \ell} \prod_{j=1}^p (x - c_j)^{k_{2,j}} S_1 \prod_{j=1}^{\epsilon_{j,1}} \partial^{-\mu} \prod_{j=1}^p (x - c_j)^{-\lambda_{j,\nu}}, \\ R_2 &= \prod_{j=1}^p (x - c_j)^{\lambda_{j,\nu} + k_{1,j}} \partial^{\mu + \ell} \prod_{j=1}^p (x - c_j)^{k_{2,j}} S_2 \prod_{j=1}^{\epsilon_{j,1}} \partial^{-\mu'} \prod_{j=1}^p (x - c_j)^{-\lambda'_{j,\nu}}\end{aligned}$$

with suitable integers  $k_{1,j}, k_{2,j}$  and  $\ell$  so that  $R_1, R_2 \in W[x; \lambda]$ .

We choose a non-zero polynomial  $S_2 \in \mathbb{C}[x]$  so that  $S_1 = S_2 \tilde{R}(\tilde{\epsilon}, \tilde{\lambda}) \in W[x]$ . Since  $P_{\mathbf{m}}(\lambda')$  is irreducible in  $W(x; \lambda)$  and  $R_2 v(x)$  is not zero, there exists  $R_3 \in W(x; \xi)$  such that  $R_3 R_2 - 1 \in W(x; \lambda) P_{\mathbf{m}}(\lambda')$ . Then  $v(x) = R u(x)$  with the operator  $R = R_3 R_1 \in W(x; \lambda)$ .

Since the equations  $P_{\mathbf{m}}(\lambda)u = 0$  and  $P_{\mathbf{m}}(\lambda')v = 0$  are irreducible  $W(x; \lambda)$ -modules, the correspondence  $v = Ru$  gives an isomorphism between these two modules. Since any solutions of these equations are holomorphically continued along the path contained in  $\mathbb{C} \setminus \{c_1, \dots, c_p\}$ , the coefficients of the operator  $R$  are holomorphic in  $\mathbb{C} \setminus \{c_1, \dots, c_p\}$ . Multiplying  $R$  by a suitable element of  $\mathbb{C}(\lambda)$ , we may assume  $R \in W(x) \otimes \mathbb{C}[\lambda]$  and  $R$  does not vanish at any  $\lambda_{j,\nu} \in \mathbb{C}$ .

Put  $f(x) = \prod_{j=1}^p (x - c_j)^n$ . Since  $R_{\mathbf{m}}(\epsilon, \lambda)$  is a shift operator, there exists  $S_{\mathbf{m}}(\epsilon, \lambda) \in W(x; \lambda)$  such that

$$(13.8) \quad f^{-1} P_{\mathbf{m}}(\lambda + \epsilon) R_{\mathbf{m}}(\epsilon, \lambda) = S_{\mathbf{m}}(\epsilon, \lambda) f^{-1} P_{\mathbf{m}}(\lambda).$$

Then Theorem 6.19 ii) shows

$$(13.9) \quad \begin{aligned}R_{\mathbf{m}}(\epsilon, \lambda)^* (f^{-1} P_{\mathbf{m}}(\lambda + \epsilon))^* &= (f^{-1} P_{\mathbf{m}}(\lambda))^* S_{\mathbf{m}}(\epsilon, \lambda)^*, \\ R_{\mathbf{m}}(\epsilon, \lambda)^* \cdot f^{-1} P_{\mathbf{m}}(\lambda + \epsilon)^\vee &= f^{-1} P_{\mathbf{m}}(\lambda)^\vee \cdot S_{\mathbf{m}}(\epsilon, \lambda)^*, \\ R_{\mathbf{m}}(\epsilon, \lambda)^* f^{-1} P_{\mathbf{m}}(\rho - \lambda - \epsilon) &= f^{-1} P_{\mathbf{m}}(\rho - \lambda) S_{\mathbf{m}}(\epsilon, \lambda)^*, \\ R_{\mathbf{m}}(\epsilon, \rho - \mu - \epsilon)^* f^{-1} P_{\mathbf{m}}(\mu) &= f^{-1} P_{\mathbf{m}}(\mu + \epsilon) S_{\mathbf{m}}(\epsilon, \rho - \mu - \epsilon)^*.\end{aligned}$$

Here we use the notation (6.52) and put  $\rho_{j,\nu} = 2(1 - n)\delta_{j,0} + n - m_{j,\nu}$  and  $\mu = \rho - \lambda - \epsilon$ . Comparing (13.9) with (13.8), we see that  $S_{\mathbf{m}}(\epsilon, \lambda)$  is a constant multiple of

the operator  $R_{\mathbf{m}}(\epsilon, \rho - \lambda - \epsilon)^*$  and  $fR_{\mathbf{m}}(\epsilon, \rho - \lambda - \epsilon)^*f^{-1} = (f^{-1}R_{\mathbf{m}}(\epsilon, \rho - \lambda - \epsilon)f)^* = R_{\mathbf{m}}(\epsilon, \tau - \lambda - \epsilon)^*$  and we have (13.3).  $\square$

Note that the operator  $R_{\mathbf{m}}(\epsilon, \lambda)$  is uniquely defined up to a constant multiple.

The following theorem gives a recurrence relation among specific local solutions with a rigid spectral type and a relation between the shift operator  $R_{\mathbf{m}}(\epsilon, \lambda)$  and the universal operator  $P_{\mathbf{m}}(\lambda)$ .

**Theorem 13.3.** *Retain the notation in Corollary 12.12 and Theorem 13.7 with a rigid tuple  $\mathbf{m}$ . Assume  $m_{j,n_j} = 1$  for  $j = 0, 1$  and 2. Put  $\epsilon = (\epsilon_{j,\nu})$ ,  $\epsilon' = (\epsilon'_{j,\nu})$ ,*

$$(13.10) \quad \epsilon_{j,\nu} = \delta_{j,1}\delta_{\nu,n_1} - \delta_{j,2}\delta_{\nu,n_2} \quad \text{and} \quad \epsilon'_{j,\nu} = \delta_{j,0}\delta_{\nu,n_0} - \delta_{j,2}\delta_{\nu,n_2}$$

for  $j = 0, \dots, p$  and  $\nu = 1, \dots, n_j$ .

i) Define  $Q_{\mathbf{m}}(\lambda) \in W(x; \lambda)$  so that  $Q_{\mathbf{m}}(\lambda)P_{\mathbf{m}}(\lambda + \epsilon') - 1 \in W(x; \lambda)P_{\mathbf{m}}(\lambda + \epsilon)$ . Then

$$(13.11) \quad R_{\mathbf{m}}(\epsilon, \lambda) - C(\lambda)Q_{\mathbf{m}}(\lambda)P_{\mathbf{m}}(\lambda + \epsilon') \in W(x; \lambda)P_{\mathbf{m}}(\lambda)$$

with a rational function  $C(\lambda)$  of  $\lambda_{j,\nu}$ .

ii) Let  $u_{\lambda}(x)$  be the local solution of  $P_{\mathbf{m}}(\lambda)u = 0$  such that  $u_{\lambda}(x) \equiv (x - c_1)^{\lambda_{1,n_1}} \bmod (x - c_1)^{\lambda_{1,n_1}+1}O_{c_1}$  for generic  $\lambda_{j,\nu}$ . Then we have the recurrence relation

$$(13.12) \quad u_{\lambda}(x) = u_{\lambda+\epsilon'}(x) + (c_1 - c_2) \prod_{\nu=0}^{K-1} \frac{\lambda(\nu+1)_{1,n_1} - \lambda(\nu)_{1,\ell(\nu)_1} + 1}{\lambda(\nu)_{1,n_1} - \lambda(\nu)_{1,\ell(\nu)_1} + 1} \cdot u_{\lambda+\epsilon}(x).$$

*Proof.* Under the notation in Corollary 12.12,  $\ell(k)_j \neq n_j$  for  $j = 0, 1, 2$  and  $k = 0, \dots, K-1$  and therefore the operation  $\partial_{max}^K$  on  $P_{\mathbf{m}}(\lambda)$  is equals to  $\partial_{max}^K$  on  $P_{\mathbf{m}}(\lambda + \epsilon)$  if they are realized by the product of the operators of the form (7.25). Hence by the induction on  $K$ , the proof of Theorem 13.2 (cf. (13.5), (13.6) and (13.7)) shows

$$(13.13) \quad P_{\mathbf{m}}(\lambda + \epsilon')u(x) = P_{\mathbf{m}}(\lambda + \epsilon')v(x)$$

for suitable functions  $u(x)$  and  $v(x)$  satisfying  $P_{\mathbf{m}}(\lambda)u(x) = P_{\mathbf{m}}(\lambda + \epsilon)v(x) = 0$  and moreover (13.12) is calculated by (4.6). Note that the identities

$$(c_1 - c_2) \prod_{j=1}^p (x - c_j)^{\lambda_j + \epsilon'_j} = \prod_{j=1}^p (x - c_j)^{\lambda_j} - \prod_{j=1}^p (x - c_j)^{\lambda_j + \epsilon_j},$$

$$\left( \partial - \sum_{j=1}^p \frac{\lambda_j + \epsilon'_j}{x - c_j} \right) \prod_{j=1}^p (x - c_j)^{\lambda_j} = \left( \partial - \sum_{j=1}^p \frac{\lambda_j + \epsilon_j}{x - c_j} \right) \prod_{j=1}^p (x - c_j)^{\lambda_j + \epsilon_j}$$

correspond to (13.12) and (13.13), respectively, when  $K = 0$ .

Note that (13.13) may be proved by (13.12). The claim i) in this theorem follows from the fact  $v(x) = Q_{\mathbf{m}}(\lambda)P_{\mathbf{m}}(\lambda + \epsilon')v(x) = Q_{\mathbf{m}}(\lambda)P_{\mathbf{m}}(\lambda + \epsilon)u(x)$ .  $\square$

In general we have the following theorem for the recurrence relation.

**Theorem 13.4** (recurrence relations). *Let  $\mathbf{m} \in \mathcal{P}^{(n)}$  be a rigid tuple with  $m_{1,n_1} = 1$  and let  $u_1(\lambda, x)$  be the normalized solution of the equation  $P_{\mathbf{m}}(\lambda)u = 0$  with respect to the exponent  $\lambda_{1,n_1}$  at  $x = c_1$ . Let  $\epsilon^{(i)}$  be shifts compatible to  $\mathbf{m}$  for  $i = 0, \dots, n$ . Then there exists polynomial functions  $r_i(x, \lambda) \in \mathbb{C}[x, \lambda]$  such that  $(r_0, \dots, r_n) \neq 0$  and*

$$(13.14) \quad \sum_{i=0}^n r_i(x, \lambda)u_1(\lambda + \epsilon^{(i)}, x) = 0.$$

*Proof.* There exist  $R_i \in \mathbb{C}(\lambda)R_{\mathbf{m}}(\epsilon^{(i)}, \lambda)$  satisfying  $u_1(\lambda + \epsilon^{(i)}, x) = R_i u_1(\lambda, x)$  and  $\text{ord } R_i < n$ . We have  $r_i(x, \lambda)$  with  $\sum_{i=0}^n r_i(x, \lambda)R_i = 0$  and the claim.  $\square$

**Example 13.5** (Gauss hypergeometric equation). Let  $P_\lambda u = 0$  and  $P_{\lambda'} v = 0$  be Fuchsian differential equations with the Riemann Scheme

$$\left\{ \begin{array}{ccc} x = \infty & 0 & 1 \\ \lambda_{0,1} & \lambda_{1,1} & \lambda_{2,1} \\ \lambda_{0,2} & \lambda_{1,2} & \lambda_{2,2} \end{array} \right\} \text{ and } \left\{ \begin{array}{ccc} x = \infty & 0 & 1 \\ \lambda'_{0,1} = \lambda_{0,1} & \lambda'_{1,1} = \lambda_{1,1} & \lambda'_{2,1} = \lambda_{2,1} \\ \lambda'_{0,2} = \lambda_{0,2} & \lambda'_{1,2} = \lambda_{1,2} + 1 & \lambda'_{2,2} = \lambda_{2,2} - 1 \end{array} \right\},$$

respectively. Here the operators  $P_\lambda = P_{\lambda_{0,1}, \lambda_{0,2}, \lambda_{1,1}, \lambda_{1,2}, \lambda_{2,1}, \lambda_{2,2}}$  and  $P_{\lambda'}$  are given in (2.51). The normalized local solution  $u_\lambda(x)$  of  $P_\lambda u = 0$  corresponding to the exponent  $\lambda_{1,2}$  at  $x = 0$  is

$$(13.15) \quad x^{\lambda_{1,2}}(1-x)^{\lambda_{2,1}} F(\lambda_{0,1} + \lambda_{1,2} + \lambda_{2,1}, \lambda_{0,2} + \lambda_{1,2} + \lambda_{2,1}, 1 - \lambda_{1,1} + \lambda_{1,2}; x).$$

By the reduction  $\left\{ \begin{array}{ccc} x = \infty & 0 & 1 \\ \lambda_{0,1} & \lambda_{1,1} & \lambda_{2,1} \\ \lambda_{0,2} & \lambda_{1,2} & \lambda_{2,2} \end{array} \right\} \rightarrow \left\{ \begin{array}{ccc} x = \infty & 0 & 1 \\ \lambda_{0,2} - \mu & \lambda_{1,2} + \mu & \lambda_{2,2} + \mu \end{array} \right\}$  with  $\mu = \lambda_{0,1} + \lambda_{1,1} + \lambda_{2,1} - 1$ , the recurrence relation (13.12) means

$$\begin{aligned} & x^{\lambda_{1,2}}(1-x)^{\lambda_{2,1}} F(\lambda_{0,1} + \lambda_{1,2} + \lambda_{2,1}, \lambda_{0,2} + \lambda_{1,2} + \lambda_{2,1}, 1 - \lambda_{1,1} + \lambda_{1,2}; x) \\ &= x^{\lambda_{1,2}}(1-x)^{\lambda_{2,1}} F(\lambda_{0,1} + \lambda_{1,2} + \lambda_{2,1}, \lambda_{0,2} + \lambda_{1,2} + \lambda_{2,1} + 1, 1 - \lambda_{1,1} + \lambda_{1,2}; x) \\ &\quad - \frac{\lambda_{0,1} + \lambda_{1,2} + \lambda_{2,1}}{1 - \lambda_{1,1} + \lambda_{1,2}} x^{\lambda_{1,2}+1} (1-x)^{\lambda_{2,1}} \\ &\quad \cdot F(\lambda_{0,1} + \lambda_{1,2} + \lambda_{2,1} + 1, \lambda_{0,2} + \lambda_{1,2} + \lambda_{2,1} + 1, 2 - \lambda_{1,1} + \lambda_{1,2}; x), \end{aligned}$$

which is equivalent to the recurrence relation

$$(13.16) \quad F(\alpha, \beta, \gamma, x) = F(\alpha, \beta + 1, \gamma; x) - \frac{\alpha}{\gamma} x F(\alpha + 1, \beta + 1, \gamma + 1; x).$$

Using the expression (2.51), we have

$$\begin{aligned} P_{\lambda+\epsilon'} - P_\lambda &= x^2(x-1)\partial + \lambda_{0,1}x^2 - (\lambda_{0,1} + \lambda_{2,1})x, \\ P_{\lambda+\epsilon'} - P_{\lambda+\epsilon} &= x(x-1)^2\partial + \lambda_{0,1}x^2 - (\lambda_{0,1} + \lambda_{1,1})x - \lambda_{1,1}, \\ (x-1)P_{\lambda+\epsilon} &= (x(x-1)\partial + (\lambda_{0,2} - 2)x + \lambda_{1,2} + 1)(P_{\lambda+\epsilon'} - P_{\lambda+\epsilon}) \\ &\quad - (\lambda_{0,1} + \lambda_{1,1} + \lambda_{2,1})(\lambda_{0,2} + \lambda_{1,2} + \lambda_{2,1})x(x-1), \\ x^{-1}(x-1)^{-1}(x(x-1)\partial + (\lambda_{0,2} - 2)x + \lambda_{1,2} + 1)(P_{\lambda+\epsilon'} - P_\lambda) &- (x-1)^{-1}P_\lambda \\ &= -(\lambda_{0,1} + \lambda_{1,1} + \lambda_{2,1})(x\partial - \lambda_{1,2} - \frac{\lambda_{2,1}x}{x-1}) \end{aligned}$$

and hence (13.11) says

$$(13.17) \quad R_{\mathbf{m}}(\epsilon, \lambda) = x\partial - \lambda_{1,2} - \lambda_{2,1} \frac{x}{x-1}.$$

In the same way we have

$$(13.18) \quad R_{\mathbf{m}}(-\epsilon, \lambda + \epsilon) = (x-1)\partial - \lambda_{2,2} + 1 - \lambda_{1,1} \frac{x-1}{x}.$$

Then

$$(13.19) \quad \begin{aligned} R_{\mathbf{m}}(-\epsilon, \lambda + \epsilon)R_{\mathbf{m}}(\epsilon, \lambda) - x^{-1}(x-1)^{-1}P_\lambda \\ = -(\lambda_{0,1} + \lambda_{1,2} + \lambda_{2,1})(\lambda_{0,2} + \lambda_{1,2} + \lambda_{2,1}) \end{aligned}$$

and since  $-R_{\mathbf{m}}(\epsilon, \tau - \lambda - \epsilon)^* = -(x\partial + (\lambda_{1,2} + 2) + (\lambda_{2,1} + 1)\frac{x}{x-1})^* = x\partial - \lambda_{1,2} - 1 - (\lambda_{2,1} + 1)\frac{x}{x-1}$  with  $\tau$  given by (13.2), the identity (13.3) means

$$(13.20) \quad P_\lambda R_{\mathbf{m}}(\epsilon, \lambda) = \left( x\partial - (\lambda_{1,2} + 1) - (\lambda_{2,1} + 1)\frac{x}{x-1} \right) P_{\lambda+\epsilon}.$$



*Remark 13.6.* Suppose  $\mathbf{m}$  is irreducibly realizable but it is not rigid. If the reductions of  $\{\lambda_{\mathbf{m}}\}$  and  $\{\lambda'_{\mathbf{m}}\}$  to Riemann schemes with a fundamental tuple of partitions are transformed into each other by suitable additions, we can construct a shift operator as in Theorem 13.2. If they are not so, we need a shift operator for equations whose spectral type are fundamental and such an operator is called a *Schlesinger transformation*.

**13.2. Relation to reducibility.** In this subsection, we will examine whether the shift operator defines a  $W(x)$ -isomorphism or doesn't.

**Theorem 13.7.** *Retain the notation in Theorem 13.2 and define a polynomial function  $c_{\mathbf{m}}(\epsilon; \lambda)$  of  $\lambda_{j,\nu}$  by*

$$(13.21) \quad R_{\mathbf{m}}(-\epsilon, \lambda + \epsilon)R_{\mathbf{m}}(\epsilon, \lambda) - c_{\mathbf{m}}(\epsilon; \lambda) \in (W[x] \otimes \mathbb{C}[\lambda])P_{\mathbf{m}}(\lambda).$$

i) *Fix  $\lambda_{j,\nu}^{\circ} \in \mathbb{C}$ . If  $c_{\mathbf{m}}(\epsilon; \lambda^{\circ}) \neq 0$ , the equation  $P_{\mathbf{m}}(\lambda^{\circ})u = 0$  is isomorphic to the equation  $P_{\mathbf{m}}(\lambda^{\circ} + \epsilon)v = 0$ . If  $c_{\mathbf{m}}(\epsilon; \lambda^{\circ}) = 0$ , then the equations  $P_{\mathbf{m}}(\lambda^{\circ})u = 0$  and  $P_{\mathbf{m}}(\lambda^{\circ} + \epsilon)v = 0$  are not irreducible.*

ii) *Under the notation in Proposition 12.16, there exists a set  $\Lambda$  whose elements  $(i, k)$  are in  $\{1, \dots, N\} \times \mathbb{Z}$  such that*

$$(13.22) \quad c_{\mathbf{m}}(\epsilon; \lambda) = C \prod_{(i,k) \in \Lambda} (\ell_i(\lambda) - k)$$

*with a constant  $C \in \mathbb{C}^{\times}$ . Here  $\Lambda$  may contain some elements  $(i, k)$  with multiplicities.*

*Proof.* Since  $u \mapsto R_{\mathbf{m}}(-\epsilon, \lambda + \epsilon)R_{\mathbf{m}}(\epsilon, \lambda)u$  defined an endomorphism of the irreducible equation  $P_{\mathbf{m}}(\lambda)u = 0$ , the existence of  $c_{\mathbf{m}}(\epsilon; \lambda)$  is clear.

If  $c_{\mathbf{m}}(\epsilon; \lambda^{\circ}) = 0$ , the non-zero homomorphism of  $P_{\mathbf{m}}(\lambda^{\circ})u = 0$  to  $P_{\mathbf{m}}(\lambda^{\circ} + \epsilon)v = 0$  defined by  $u = R_{\mathbf{m}}(\epsilon; \lambda^{\circ})v$  is not surjective nor injective. Hence the equations are not irreducible. If  $c_{\mathbf{m}}(\epsilon; \lambda^{\circ}) \neq 0$ , then the homomorphism is an isomorphism and the equations are isomorphic to each other.

The claim ii) follows from Proposition 12.16.  $\square$

**Theorem 13.8.** *Retain the notation in Theorem 13.7 with a rigid tuple  $\mathbf{m}$ . Fix a linear function  $\ell(\lambda)$  of  $\lambda$  such that the condition  $\ell(\lambda) = 0$  implies the reducibility of the universal equation  $P_{\mathbf{m}}(\lambda)u = 0$ .*

i) *If there is no irreducible realizable subtuple  $\mathbf{m}'$  of  $\mathbf{m}$  which is compatible to  $\ell(\lambda)$  and  $\ell(\lambda + \epsilon)$ ,  $\ell(\lambda)$  is a factor of  $c_{\mathbf{m}}(\epsilon; \lambda)$ .*

*If there is no dual decomposition of  $\mathbf{m}$  with respect to the pair  $\ell(\lambda)$  and  $\ell(\lambda + \epsilon)$ ,  $\ell(\lambda)$  is not a factor of  $c_{\mathbf{m}}(\epsilon; \lambda)$ . Here we define that the decomposition (12.51) is dual with respect to the pair  $\ell(\lambda)$  and  $\ell(\lambda + \epsilon)$  if the following conditions are valid.*

$$(13.23) \quad \mathbf{m}' \text{ is an irreducibly realizable subtuple of } \mathbf{m} \text{ compatible to } \ell(\lambda),$$

$$(13.24) \quad \mathbf{m}'' \text{ is a subtuple of } \mathbf{m} \text{ compatible to } \ell(\lambda + \epsilon).$$

ii) *Suppose there exists a decomposition  $\mathbf{m} = \mathbf{m}' \oplus \mathbf{m}''$  with rigid tuples  $\mathbf{m}'$  and  $\mathbf{m}''$  such that  $\ell(\lambda) = |\{\lambda_{\mathbf{m}}\}| + k$  with  $k \in \mathbb{Z}$  and  $\ell(\lambda + \epsilon) = \ell(\lambda) + 1$ . Then  $\ell(\lambda)$  is a factor of  $c_{\mathbf{m}}(\epsilon; \lambda)$  if and only if  $k = 0$ .*

*Proof.* Fix generic complex numbers  $\lambda_{j,\nu} \in \mathbb{C}$  satisfying  $\ell(\lambda) = |\{\lambda_{\mathbf{m}}\}| = 0$ . Then we may assume  $\lambda_{j,\nu} - \lambda_{j,\nu'} \notin \mathbb{Z}$  for  $1 \leq \nu < \nu' \leq n_j$  and  $j = 0, \dots, p$ .

i) The shift operator  $R := R_{\mathbf{m}}(-\epsilon, \lambda + \epsilon)$  gives a non-zero  $W(x)$ -homomorphism of the equation  $P_{\mathbf{m}}(\lambda + \epsilon)v = 0$  to  $P_{\mathbf{m}}(\lambda)u = 0$  by the correspondence  $v = Ru$ . Since the equation  $P_{\mathbf{m}}(\lambda)u = 0$  is reducible, we examine the decompositions of  $\mathbf{m}$  described in Proposition 12.16. Note that the genericity of  $\lambda_{j,\nu} \in \mathbb{C}$  assures that the subtuple  $\mathbf{m}'$  of  $\mathbf{m}$  corresponding to a decomposition  $P_{\mathbf{m}}(\lambda) = P''P'$  is uniquely

determined, namely,  $\mathbf{m}'$  corresponds to the spectral type of the monodromy of the equation  $P'u = 0$ .

If the shift operator  $R$  is bijective, there exists a subtuple  $\mathbf{m}'$  of  $\mathbf{m}$  compatible to  $\ell(\lambda)$  and  $\ell(\lambda + \epsilon)$  because  $R$  induces an isomorphism of monodromy.

Suppose  $\ell(\lambda)$  is a factor of  $c_{\mathbf{m}}(\epsilon; \lambda)$ . Then  $R$  is not bijective. We assume that the image of  $R$  is the equation  $P''\bar{u} = 0$  and the kernel of  $R$  is the equation  $P'_\epsilon\bar{v} = 0$ . Then  $P_{\mathbf{m}}(\lambda) = P''P'$  and  $P_{\mathbf{m}}(\lambda + \epsilon) = P'_\epsilon P''$  with suitable Fuchsian differential operators  $P'$  and  $P''$ . Note that the spectral type of the monodromy of  $P'u = 0$  and  $P''v = 0$  corresponds to  $\mathbf{m}'$  and  $\mathbf{m}''$  with  $\mathbf{m} = \mathbf{m}' + \mathbf{m}''$ . Applying Proposition 12.16 to the decompositions  $P_{\mathbf{m}}(\lambda) = P''P'$  and  $P_{\mathbf{m}}(\lambda + \epsilon) = P'_\epsilon P''$ , we have a dual decomposition (12.51) of  $\mathbf{m}$  with respect to the pair  $\ell(\lambda)$  and  $\ell(\lambda + \epsilon)$ .

ii) Since  $P_{\mathbf{m}}(\lambda)u = 0$  is reducible, we have a decomposition  $P_{\mathbf{m}}(\lambda) = P''P'$  with  $0 < \text{ord } P' < \text{ord } P_{\mathbf{m}}(\lambda)$ . We may assume  $P'u = 0$  and let  $\tilde{\mathbf{m}}'$  be the spectral type of the monodromy of the equation  $P'u = 0$ . Then  $\tilde{\mathbf{m}}' = \ell_1\mathbf{m}' + \ell_2\mathbf{m}''$  with integers  $\ell_1$  and  $\ell_2$  because  $\{|\lambda_{\tilde{\mathbf{m}}'}|\} \in \mathbb{Z}_{\leq 0}$ . Since  $P'u = 0$  is irreducible,  $2 \geq \text{idx } \tilde{\mathbf{m}}' = 2(\ell_1^2 - \ell_1\ell_2 + \ell_2^2)$  and therefore  $(\ell_1, \ell_2) = (1, 0)$  or  $(0, 1)$ . Hence the claim follows from i) and the identity  $|\{\lambda_{\mathbf{m}'}\}| + |\{\lambda_{\mathbf{m}''}\}| = 1$   $\square$

When  $\mathbf{m}$  is simply reducible (cf. Definition 8.14), each linear form of  $\lambda_{j,\nu}$  describing the reducibility uniquely corresponds to a rigid decomposition of  $\mathbf{m}$  and therefore Theorem 13.8 gives the necessary and sufficient condition for the bijectivity of the shift operator  $R_{\mathbf{m}}(\epsilon, \lambda)$ .

**Example 13.9** ( $EO_4$ ). Let  $P(\lambda)u = 0$  and  $P(\lambda')v = 0$  be the Fuchsian differential equation with the Riemann schemes

$$\left\{ \begin{array}{ccc} \lambda_{0,1} & [\lambda_{1,1}]_{(2)} & [\lambda_{2,1}]_{(2)} \\ \lambda_{0,2} & \lambda_{1,2} & [\lambda_{2,2}]_{(2)} \\ \lambda_{0,3} & \lambda_{1,3} & \\ \lambda_{0,4} & & \end{array} \right\} \text{ and } \left\{ \begin{array}{ccc} \lambda_{0,1} & [\lambda_{1,1}]_{(2)} & [\lambda_{2,1}]_{(2)} \\ \lambda_{0,2} & \lambda_{1,2} & [\lambda_{2,2}]_{(2)} \\ \lambda_{0,3} & \lambda_{1,3} + 1 & \\ \lambda_{0,4} - 1 & & \end{array} \right\},$$

respectively. Since the condition of the reducibility of the equation corresponds to rigid decompositions (12.63), it easily follows from Theorem 13.8 that the shift operator between  $P(\lambda)u = 0$  and  $P(\lambda')v = 0$  is bijective if and only if

$$\begin{cases} \lambda_{0,4} + \lambda_{1,2} + \lambda_{2,\mu} - 1 \neq 0 & (1 \leq \mu \leq 2), \\ \lambda_{0,\nu} + \lambda_{0,\nu'} + \lambda_{1,1} + \lambda_{1,3} + \lambda_{2,1} + \lambda_{2,2} - 1 \neq 0 & (1 \leq \nu < \nu' \leq 3). \end{cases}$$

In general, for a shift  $\epsilon = (\epsilon_{j,\nu})$  compatible to the spectral type 1111, 211, 22, the shift operator between  $P(\lambda)u = 0$  and  $P(\lambda + \epsilon)v = 0$  is bijective if and only if the values of each function in the list

$$(13.25) \quad \lambda_{0,\nu} + \lambda_{1,1} + \lambda_{2,\mu} \quad (1 \leq \nu \leq 4, 1 \leq \mu \leq 2),$$

$$(13.26) \quad \lambda_{0,\nu} + \lambda_{0,\nu'} + \lambda_{1,1} + \lambda_{1,3} + \lambda_{2,1} + \lambda_{2,2} - 1 \quad (1 \leq \nu < \nu' \leq 4)$$

are

$$(13.27) \quad \begin{cases} \text{not integers for } \lambda \text{ and } \lambda + \epsilon \\ \text{or positive integers for } \lambda \text{ and } \lambda + \epsilon \\ \text{or non-positive integers for } \lambda \text{ and } \lambda + \epsilon. \end{cases}$$

Note that the shift operator gives a homomorphism between monodromies (cf. (3.23)).

The following conjecture gives  $c_{\mathbf{m}}(\epsilon; \lambda)$  under certain conditions.

**Conjecture 13.10.** Retain the assumption that  $\mathbf{m} = (\lambda_{j,\nu})_{\substack{0 \leq j \leq p \\ 1 \leq \nu \leq n_j}} \in \mathcal{P}_{p+1}^{(n)}$  is rigid.

i) If  $\ell(\lambda) = \ell(\lambda + \epsilon)$  in Theorem 13.8, then  $\ell(\lambda)$  is not a factor of  $c_{\mathbf{m}}(\epsilon; \lambda)$ ,

ii) Assume  $m_{1,n_1} = m_{2,n_2} = 1$  and

$$(13.28) \quad \epsilon := (\epsilon_{j,\nu})_{\substack{0 \leq j \leq p \\ 1 \leq \nu \leq n_j}}, \quad \epsilon_{j,\nu} = \delta_{j,1} \delta_{\nu,n_1} - \delta_{j,2} \delta_{\nu,n_2},$$

Then we have

$$(13.29) \quad c_{\mathbf{m}}(\epsilon; \lambda) = C \prod_{\substack{\mathbf{m} = \mathbf{m}' \oplus \mathbf{m}'' \\ m_{1,n_1} = m_{2,n_2} = 1}} |\{\lambda_{\mathbf{m}'}\}|$$

with  $C \in \mathbb{C}^\times$ .

Suppose the spectral type  $\mathbf{m}$  is of *Okubo type*, namely,

$$(13.30) \quad m_{1,1} + \cdots + m_{p,1} = (p-1) \text{ ord } \mathbf{m}.$$

Then some shift operators are easily obtained as follows. By a suitable addition we may assume that the Riemann scheme is

$$(13.31) \quad \left\{ \begin{array}{cccc} x = \infty & x = c_1 & \cdots & x = c_p \\ [\lambda_{0,1}]_{(m_{0,1})} & [0]_{(m_{1,1})} & \cdots & [0]_{(m_{p,1})} \\ [\lambda_{0,2}]_{(m_{0,2})} & [\lambda_{1,2}]_{(m_{1,2})} & \cdots & [\lambda_{p,2}]_{(m_{p,2})} \\ \vdots & \vdots & \vdots & \vdots \\ [\lambda_{0,n_0}]_{(m_{0,n_0})} & [\lambda_{1,n_1}]_{(m_{1,n_1})} & \cdots & [\lambda_{p,n_p}]_{(m_{p,n_p})} \end{array} \right\}$$

and the corresponding differential equation  $Pu = 0$  is of the form

$$P_{\mathbf{m}}(\lambda) = \prod_{j=1}^p (x - c_j)^{n - m_{j,1}} \frac{d^n}{dx^n} + \sum_{k=0}^{n-1} \prod_{j=1}^p (x - c_j)^{\max\{k - m_{j,1}, 0\}} a_k(x) \frac{d^k}{dx^k}.$$

Here  $a_k(x)$  is a polynomial of  $x$  whose degree is not larger than  $k - \sum_{j=1}^n \max\{k - m_{j,1}, 0\}$ . Moreover we have

$$(13.32) \quad a_0(x) = \prod_{\nu=1}^{n_0} \prod_{i=0}^{m_{0,\nu}-1} (\lambda_{0,\nu} + i).$$

Define the differential operators  $R_1$  and  $R_{\mathbf{m}}(\lambda) \in W[x] \otimes \mathbb{C}[\lambda]$  by

$$(13.33) \quad R_1 = \frac{d}{dx} \quad \text{and} \quad P_{\mathbf{m}}(\lambda) = -R_{\mathbf{m}}(\lambda)R_1 + a_0(x).$$

Let  $P_{\mathbf{m}}(\lambda')v = 0$  be the differential equation with the Riemann scheme

$$(13.34) \quad \left\{ \begin{array}{cccc} x = \infty & x = c_1 & \cdots & x = c_p \\ [\lambda_{0,1} + 1]_{(m_{0,1})} & [0]_{(m_{1,1})} & \cdots & [0]_{(m_{p,1})} \\ [\lambda_{0,2} + 1]_{(m_{0,2})} & [\lambda_{1,2} - 1]_{(m_{1,2})} & \cdots & [\lambda_{p,2} - 1]_{(m_{p,2})} \\ \vdots & \vdots & \vdots & \vdots \\ [\lambda_{0,n_0} + 1]_{(m_{0,n_0})} & [\lambda_{1,n_1} - 1]_{(m_{1,n_1})} & \cdots & [\lambda_{p,n_p} - 1]_{(m_{p,n_p})} \end{array} \right\}.$$

Then the correspondences  $u = R_{\mathbf{m}}(\lambda)v$  and  $v = R_1u$  give  $W(x)$ -homomorphisms between the differential equations.

**Proposition 13.11.** *Let  $\mathbf{m} = \{m_{j,\nu}\}_{\substack{0 \leq j \leq p \\ 1 \leq \nu \leq n_j}}$  be a rigid tuple of partitions satisfying*

(13.30). *Putting*

$$(13.35) \quad \epsilon_{j,\nu} = \begin{cases} 1 & (j = 0, 1 \leq \nu \leq n_0), \\ \delta_{\nu,0} - 1 & (1 \leq j \leq p, 1 \leq \nu \leq n_j), \end{cases}$$

*we have*

$$(13.36) \quad c_{\mathbf{m}}(\epsilon; \lambda) = \prod_{\nu=1}^{n_0} \prod_{i=0}^{m_{0,\nu}-1} (\lambda_{0,\nu} + \lambda_{1,1} + \cdots + \lambda_{p,1} + i).$$

*Proof.* By suitable additions the proposition follows from the result assuming  $\lambda_{j,1} = 0$  for  $j = 1, \dots, p$ , which has been shown.  $\square$

**Example 13.12.** The generalized hypergeometric equations with the Riemann schemes

$$(13.37) \quad \left\{ \begin{array}{ccc} \lambda_{0,1} & \lambda_{1,1} & [\lambda_{2,1}]_{(n-1)} \\ \vdots & \vdots & \\ \lambda_{0,\nu} & \lambda_{1,\nu_o} & \\ \vdots & \vdots & \\ \lambda_{0,n} & \lambda_{1,n} & \lambda_{2,2} \end{array} \right\} \text{ and } \left\{ \begin{array}{ccc} \lambda_{0,1} & \lambda_{1,1} & [\lambda_{2,1}]_{(n-1)} \\ \vdots & \vdots & \\ \lambda_{0,\nu} & \lambda_{1,\nu_o} + 1 & \\ \vdots & \vdots & \\ \lambda_{0,n} & \lambda_{1,n} & \lambda_{2,2} - 1 \end{array} \right\}$$

whose spectral type is  $\mathbf{m} = 1^n, 1^n, (n-1)1$  are isomorphic to each other by the shift operator if and only if

$$(13.38) \quad \lambda_{0,\nu} + \lambda_{1,\nu_o} + \lambda_{2,1} \neq 0 \quad (\nu = 1, \dots, n).$$

This statement follows from Proposition 13.11 with suitable additions.

Theorem 13.8 shows that in general  $P(\lambda)u = 0$  with the Riemann scheme  $\{\lambda_{\mathbf{m}}\}$  is  $W(x)$ -isomorphic to  $P(\lambda + \epsilon)v = 0$  by the shift operator if and only if the values of the function  $\lambda_{0,\nu} + \lambda_{1,\mu} + \lambda_{2,1}$  satisfy (13.27) for  $1 \leq \nu \leq n$  and  $1 \leq \mu \leq n$ . Here  $\epsilon$  is any shift compatible to  $\mathbf{m}$ .

The shift operator between

$$(13.39) \quad \left\{ \begin{array}{ccc} \lambda_{0,1} & \lambda_{1,1} & [\lambda_{2,1}]_{(n-1)} \\ \lambda_{0,2} & \lambda_{1,2} & \lambda_{2,2} \\ \vdots & \vdots & \\ \lambda_{0,n} & \lambda_{1,n} & \end{array} \right\} \text{ and } \left\{ \begin{array}{ccc} \lambda_{0,1} & \lambda_{1,1} + 1 & [\lambda_{2,1}]_{(n-1)} \\ \lambda_{0,2} & \lambda_{1,2} - 1 & \lambda_{2,2} \\ \vdots & \vdots & \\ \lambda_{0,n} & \lambda_{1,n} & \end{array} \right\}$$

is bijective if and only if

$$\lambda_{0,\nu} + \lambda_{1,1} + \lambda_{2,1} \neq 0 \quad \text{and} \quad \lambda_{0,\nu} + \lambda_{1,2} + \lambda_{2,1} \neq 1 \quad \text{for } \nu = 1, \dots, n.$$

Hence if  $\lambda_{1,1} = 0$  and  $\lambda_{1,2} = 1$  and  $\lambda_{0,1} + \lambda_{2,1} = 0$ , the shift operator defines a non-zero endomorphism which is not bijective and therefore the monodromy of the space of the solutions are decomposed into a direct sum of the spaces of solutions of two Fuchsian differential equations. The other parameters are generic in this case, the decomposition is unique and the dimension of the smaller space equals 1. When  $n = 2$  and  $(c_0, c_1, c_2) = (\infty, 1, 0)$  and  $\lambda_{2,1}$  and  $\lambda_{2,2}$  are generic, the space equals  $\mathbb{C}x^{\lambda_{2,1}} \oplus \mathbb{C}x^{\lambda_{2,2}}$

**13.3. Polynomial solutions.** We characterize some polynomial solutions of a differential equation of Okubo type.

**Proposition 13.13.** *Retain the notation in §13.1. Let  $P_{\mathbf{m}}(\lambda)u = 0$  be the differential equation with the Riemann scheme (13.31). Suppose that  $\mathbf{m}$  is rigid and satisfies (13.30). Suppose moreover that there exists  $j_o$  satisfying  $m_{j_o,1} = 1$  and  $0 \leq j_o \leq p$ . Fix a complex number  $C$ . Suppose  $\lambda_{0,1} = -C$  and  $\lambda_{j,\nu} \notin \mathbb{Z}$  for  $j = 0, \dots, p$  and  $\nu = 2, \dots, n_j$ . Then the equation has a polynomial solution of degree  $k$  if and only if  $C = k$ .*

*We denote the polynomial solution by  $p_\lambda$ . Then  $p'_\lambda$  is a polynomial solution of  $P_{\mathbf{m}}(\lambda + \epsilon)v = 0$  under the notation (13.35). Moreover*

$$(13.40) \quad R_{\mathbf{m}}(\lambda) \circ R_{\mathbf{m}}(\lambda + \epsilon) \circ \dots \circ R_{\mathbf{m}}(\lambda + (k-1)\epsilon)1$$

*is a non-zero constant multiple of  $p_\lambda$  under the notation (13.33).*

*Proof.* Since  $\mathbf{m} = (\delta_{1,\nu})_{\substack{0 \leq j \leq p \\ 1 \leq \nu \leq n_j}} \oplus (m_{j,\nu} - \delta_{1,\nu})_{\substack{0 \leq j \leq p \\ 1 \leq \nu \leq n_j}}$  is a rigid decomposition of  $\mathbf{m}$ , we have  $P_{\mathbf{m}}(\lambda) = P_1 \partial$  with suitable  $P_1 \in W(x)$  when  $C = 0$ . Note that  $R_{\mathbf{m}}(\lambda + \ell\epsilon)$  defines an isomorphism of the equation  $P_{\mathbf{m}}(\lambda + (\ell+1)\epsilon)u_{k+1} = 0$  to the equation  $P_{\mathbf{m}}(\lambda + \ell\epsilon)u_k = 0$  by  $u_k = R_{\mathbf{m}}(\lambda + \ell\epsilon)u_{k+1}$  if  $C \neq \ell$ , the function (13.40) is a polynomial solution of  $P_{\mathbf{m}}(\lambda)u = 0$ . The remaining part of the proposition is clear.  $\square$

*Remark 13.14.* We have not used the assumption that  $\mathbf{m}$  is rigid in Proposition 13.11 and Proposition 13.13 and hence the propositions are valid without this assumption.

#### 14. CONNECTION PROBLEM

**14.1. Connection formula.** For a realizable tuple  $\mathbf{m} \in \mathcal{P}_{p+1}$  let  $P_{\mathbf{m}}u = 0$  be a universal Fuchsian differential equation with the Riemann scheme

$$(14.1) \quad \left\{ \begin{array}{cccccc} x = 0 & c_1 = 1 & \cdots & c_j & \cdots & c_p = \infty \\ [\lambda_{0,1}]_{(m_{0,1})} & [\lambda_{1,1}]_{(m_{1,1})} & \cdots & [\lambda_{j,1}]_{(m_{j,1})} & \cdots & [\lambda_{p,1}]_{(m_{p,1})} \\ \vdots & \vdots & \vdots & \vdots & \vdots & \vdots \\ [\lambda_{0,n_0}]_{(m_{0,n_0})} & [\lambda_{1,n_1}]_{(m_{1,n_1})} & \cdots & [\lambda_{j,n_j}]_{(m_{j,n_j})} & \cdots & [\lambda_{p,n_p}]_{(m_{p,n_p})} \end{array} \right\}.$$

The singular points of the equation are  $c_j$  for  $j = 0, \dots, p$ . In this subsection we always assume  $c_0 = 0$ ,  $c_1 = 1$  and  $c_p = \infty$  and  $c_j \notin [0, 1]$  for  $j = 2, \dots, p-1$ . We also assume that  $\lambda_{j,\nu}$  are generic.

**Definition 14.1** (connection coefficients). Suppose  $\lambda_{j,\nu}$  are generic under the Fuchs relation. Let  $u_0^{\lambda_{0,\nu_0}}$  and  $u_1^{\lambda_{1,\nu_1}}$  be normalized local solutions of  $P_{\mathbf{m}} = 0$  at  $x = 0$  and  $x = 1$  corresponding to the exponents  $\lambda_{0,\nu_0}$  and  $\lambda_{1,\nu_1}$ , respectively, so that  $u_0^{\lambda_{0,\nu_0}} \equiv x^{\lambda_{0,\nu_0}} \pmod{x^{\lambda_{0,\nu_0}+1}\mathcal{O}_0}$  and  $u_1^{\lambda_{1,\nu_1}} \equiv (1-x)^{\lambda_{1,\nu_1}} \pmod{(1-x)^{\lambda_{1,\nu_1}+1}\mathcal{O}_1}$ . Here  $1 \leq \nu_0 \leq n_0$  and  $1 \leq \nu_1 \leq n_1$ . If  $m_{0,\nu_0} = 1$ ,  $u_0^{\lambda_{0,\nu_0}}$  is uniquely determined and then the analytic continuation of  $u_0^{\lambda_{0,\nu_0}}$  to  $x = 1$  along  $(0, 1) \subset \mathbb{R}$  defines a *connection coefficient* with respect to  $u_1^{\lambda_{1,\nu_1}}$ , which is denoted by  $c(0 : \lambda_{0,\nu_0} \rightsquigarrow 1 : \lambda_{1,\nu_1})$  or simply by  $c(\lambda_{0,\nu_0} \rightsquigarrow \lambda_{1,\nu_1})$ . The connection coefficient  $c(1 : \lambda_{1,\nu_1} \rightsquigarrow 0 : \lambda_{0,\nu_0})$  or  $c(\lambda_{1,\nu_1} \rightsquigarrow \lambda_{0,\nu_0})$  of  $u_1^{\lambda_{1,\nu_1}}$  with respect to  $u_0^{\lambda_{0,\nu_0}}$  are similarly defined if  $m_{1,\nu_1} = 1$ .

Moreover we define  $c(c_i : \lambda_{i,\nu_i} \rightsquigarrow c_j : \lambda_{j,\nu_j})$  by using a suitable linear fractional transformation  $T$  of  $\mathbb{C} \cup \{\infty\}$  which transforms  $\{c_i, c_j\}$  to  $\{0, 1\}$  so that  $T(c_\nu) \notin (0, 1)$  for  $\nu = 0, \dots, p$ . If  $p = 2$ , we define the map  $T$  so that  $T(c_k) = \infty$  for the other singular point  $c_k$ . For example if  $c_j \notin [0, 1]$  for  $j = 2, \dots, p-1$ , we put  $T(x) = \frac{x}{x-1}$  to define  $c(0 : \lambda_{0,\nu_0} \rightsquigarrow \infty : \lambda_{p,\nu_p})$  or  $c(\infty : \lambda_{p,\nu_p} \rightsquigarrow 0 : \lambda_{0,\nu_0})$ .

In the definition  $u_0^{\lambda_{0,\nu_0}}(x) = x^{\lambda_{0,\nu_0}}\phi(x)$  with analytic function  $\phi(x)$  at 0 which satisfies  $\phi(0) = 1$  and if  $\operatorname{Re} \lambda_{1,\nu_1} < \operatorname{Re} \lambda_{1,\nu}$  for  $\nu \neq \nu_1$ , we have

$$(14.2) \quad c(\lambda_{0,\nu_0} \rightsquigarrow \lambda_{1,\nu_1}) = \lim_{x \rightarrow 1-0} (1-x)^{-\lambda_{1,\nu_1}} u_0^{\lambda_{0,\nu_0}}(x) \quad (x \in [0, 1))$$

by the analytic continuation. The connection coefficient  $c(\lambda_{0,\nu_0} \rightsquigarrow \lambda_{1,\nu_1})$  meromorphically depends on spectral parameters  $\lambda_{j,\nu}$ . It also holomorphically depends on accessory parameters  $g_i$  and singular points  $\frac{1}{c_j}$  ( $j = 2, \dots, p-1$ ) in a neighborhood of given values of parameters.

The main purpose in this subsection is to get the explicit expression of the connection coefficients in terms of Gamma functions when  $\mathbf{m}$  is rigid and  $m_{0,\nu} = m_{1,\nu} = 1$ .

Fist we prove the following key lemma which describes the effect of a middle convolution on connection coefficients.

**Lemma 14.2.** *Using the integral transformation (2.37), we put*

$$(14.3) \quad (T_{a,b}^\mu u)(x) := x^{-a-\mu}(1-x)^{-b-\mu} I_0^\mu x^a (1-x)^b u(x),$$

$$(14.4) \quad (S_{a,b}^\mu u)(x) := x^{-a-\mu} I_0^\mu x^a (1-x)^b u(x)$$

for a continuous function  $u(x)$  on  $[0, 1]$ . Suppose  $\operatorname{Re} a \geq 0$  and  $\operatorname{Re} \mu > 0$ . Under the condition  $\operatorname{Re} b + \operatorname{Re} \mu < 0$  or  $\operatorname{Re} b + \operatorname{Re} \mu > 0$ ,  $(T_{a,b}^\mu u)(x)$  or  $S_{a,b}^\mu(u)(x)$  defines a continuous function on  $[0, 1]$ , respectively, and we have

$$(14.5) \quad T_{a,b}^\mu(u)(0) = S_{a,b}^\mu(u)(0) = \frac{\Gamma(a+1)}{\Gamma(a+\mu+1)} u(0),$$

$$(14.6) \quad \frac{T_{a,b}^\mu(u)(1)}{T_{a,b}^\mu(u)(0)} = \frac{u(1)}{u(0)} C_{a,b}^\mu, \quad C_{a,b}^\mu := \frac{\Gamma(a+\mu+1)\Gamma(-\mu-b)}{\Gamma(a+1)\Gamma(-b)},$$

$$(14.7) \quad \frac{S_{a,b}^\mu(u)(1)}{S_{a,b}^\mu(u)(0)} = \frac{1}{u(0)} \frac{\Gamma(a+\mu+1)}{\Gamma(\mu)\Gamma(a+1)} \int_0^1 t^a (1-t)^{b+\mu-1} u(t) dt.$$

*Proof.* Suppose  $\operatorname{Re} a \geq 0$  and  $0 < \operatorname{Re} \mu < -\operatorname{Re} b$ . Then

$$\begin{aligned} & \Gamma(\mu) T_{a,b}^\mu(u)(x) \\ &= x^{-a-\mu}(1-x)^{-b-\mu} \int_0^x t^a (1-t)^b (x-t)^{\mu-1} u(t) dt \quad (t = xs_1, 0 \leq x < 1) \\ &= (1-x)^{-b-\mu} \int_0^1 s_1^a (1-s_1)^{\mu-1} (1-xs_1)^b u(xs_1) ds_1 \\ &= \int_0^1 s_1^a \left(\frac{1-s_1}{1-x}\right)^\mu \left(\frac{1-xs_1}{1-x}\right)^b u(xs_1) \frac{ds}{1-s_1} \\ &= \int_0^1 (1-s_2)^a \left(\frac{s_2}{1-x}\right)^\mu \left(1 + \frac{xs_2}{1-x}\right)^b u(x-xs_2) \frac{ds_2}{s_2} \quad (s_1 = 1-s_2) \\ &= \int_0^{\frac{1}{1-x}} (1-s(1-x))^a s^\mu (1+xs)^b u(x-x(1-x)s) \frac{ds}{s} \quad (s_2 = (1-x)s). \end{aligned}$$

Since

$$|s_1^a (1-s_1)^{\mu-1} (1-xs_1)^b u(xs_1)| \leq \max\{(1-s_1)^{\operatorname{Re} \mu - 1}, 1\} 3^{-\operatorname{Re} b} \max_{0 \leq t \leq 1} |u(t)|$$

for  $0 \leq s_1 < 1$  and  $0 \leq x \leq \frac{2}{3}$ ,  $T_{a,b}^\mu(u)(x)$  is continuous for  $x \in [0, \frac{2}{3}]$ . We have

$$|(1-s(1-x))^a s^{\mu-1} (1+xs)^b u(x-x(1-x)s)| \leq s^{\operatorname{Re} \mu - 1} (1 + \frac{s}{2})^{\operatorname{Re} b} \max_{0 \leq t \leq 1} |u(t)|$$

for  $\frac{1}{2} \leq x \leq 1$  and  $0 < s \leq \frac{1}{1-x}$  and therefore  $T_{a,b}^\mu(u)(x)$  is continuous for  $x \in (\frac{1}{2}, 1]$ .

Hence  $T_{a,b}^\mu(x)$  defines a continuous function on  $[0, 1]$  and

$$T_{a,b}^\mu(u)(0) = \frac{1}{\Gamma(\mu)} \int_0^1 (1-s_2)^a s_2^\mu u(0) \frac{ds_2}{s_2} = \frac{\Gamma(a+1)}{\Gamma(a+\mu+1)} u(0),$$

$$T_{a,b}^\mu(u)(1) = \frac{1}{\Gamma(\mu)} \int_0^\infty s^\mu (1+s)^b u(1) \frac{ds}{s}$$

$$(t = \frac{s}{1+s} = 1 - \frac{1}{1+s}, \frac{1}{1+s} = 1-t, 1+s = \frac{1}{1-t}, s = \frac{1}{1-t} - 1 = \frac{t}{1-t}, \frac{ds}{dt} = -\frac{1}{(1-t)^2})$$

$$= \frac{1}{\Gamma(\mu)} \int_0^1 \left(\frac{t}{1-t}\right)^{\mu-1} (1-t)^{-b-2} u(1) dt = \frac{\Gamma(-\mu-b)}{\Gamma(-b)} u(1).$$

The claims for  $S_{a,b}^\mu$  are clear from

$$\Gamma(\mu) S_{a,b}^\mu(u)(x) = \int_0^1 s_1^a (1-s_1)^{\mu-1} (1-xs_1)^b u(xs_1) ds_1.$$

□

This lemma is useful for the middle convolution  $mc_\mu$  not only when it gives a reduction but also when it doesn't change the spectral type.

**Example 14.3.** Applying Lemma 14.2 to the solution

$$u_0^{\lambda_0+\mu}(x) = \int_0^x t^{\lambda_0}(1-t)^{\lambda_1} \left( \prod_{j=2}^{p-1} \left(1 - \frac{t}{c_j}\right)^{\lambda_j} \right) (x-t)^{\mu-1} dt$$

of the Jordan-Pochhammer equation (cf. Example 2.8 iii)) with the Riemann scheme

$$\left\{ \begin{array}{cccccc} x = 0 & c_1 = 1 & \cdots & c_j & \cdots & c_p = \infty \\ [0]_{(p-1)} & [0]_{(p-1)} & \cdots & [0]_{(p-1)} & \cdots & [1-\mu]_{(p-1)} \\ \lambda_0 + \mu & \lambda_1 + \mu & \cdots & \lambda_j + \mu & \cdots & -\sum_{\nu=0}^{p-1} \lambda_\nu - \mu \end{array} \right\},$$

we have

$$c(0: \lambda_0 + \mu \rightsquigarrow 1: \lambda_1 + \mu) = \frac{\Gamma(\lambda_0 + \mu + 1)\Gamma(-\lambda_1 - \mu)}{\Gamma(\lambda_0 + 1)\Gamma(-\lambda_1)} \prod_{j=2}^{p-1} \left(1 - \frac{1}{c_j}\right)^{\lambda_j},$$

$$c(0: \lambda_0 + \mu \rightsquigarrow 1: 0) = \frac{\Gamma(\lambda_0 + \mu + 1)}{\Gamma(\mu)\Gamma(\lambda_0 + 1)} \int_0^1 t^{\lambda_0}(1-t)^{\lambda_1+\mu-1} \prod_{j=1}^{p-1} \left(1 - \frac{t}{c_j}\right)^{\lambda_j} dt.$$

Moreover the equation  $Pu = 0$  with

$$P := \text{RAd}(\partial^{-\mu'}) \text{RAd}(x^{\lambda'}) \text{RAd}(\partial^{-\mu}) \text{RAd}(x^{\lambda_0}(1-x)^{\lambda_1}) \partial$$

is satisfied by the generalized hypergeometric function  ${}_3F_2$  with the Riemann scheme

$$\left\{ \begin{array}{ccc} x = 0 & 1 & \infty \\ 0 & [0]_{(2)} & 1 - \mu' \\ \lambda' + \mu' & & 1 - \lambda' - \mu - \mu' \\ \lambda_0 + \lambda' + \mu + \mu' & \lambda_1 + \mu + \mu' & -\lambda_0 - \lambda_1 - \lambda' - \mu - \mu' \end{array} \right\}$$

corresponding to 111, 21, 111 and therefore

$$\begin{aligned} c(\lambda_0 + \lambda' + \mu + \mu' \rightsquigarrow \lambda_1 + \mu + \mu') &= C_{\lambda_0, \lambda_1}^{\mu'} \cdot C_{\lambda_0 + \lambda' + \mu, \lambda_1 + \mu}^{\mu'} \\ &= \frac{\Gamma(\lambda_0 + \mu + 1)\Gamma(-\lambda_1 - \mu)}{\Gamma(\lambda_0 + 1)\Gamma(-\lambda_1)} \cdot \frac{\Gamma(\lambda_0 + \lambda' + \mu + \mu' + 1)\Gamma(-\lambda_1 - \mu - \mu')}{\Gamma(\lambda_0 + \lambda' + \mu + 1)\Gamma(-\lambda_1 - \mu)} \\ &= \frac{\Gamma(\lambda_0 + \mu + 1)\Gamma(\lambda_0 + \lambda' + \mu + \mu' + 1)\Gamma(-\lambda_1 - \mu - \mu')}{\Gamma(\lambda_0 + 1)\Gamma(-\lambda_1)\Gamma(\lambda_0 + \lambda' + \mu + 1)}. \end{aligned}$$

We further examine the connection coefficient.

In general putting  $c_0 = 0$  and  $c_1 = 1$  and  $\lambda_1 = \sum_{k=0}^p \lambda_{k,1} - 1$ , we have

$$\begin{aligned} &\left\{ \begin{array}{cc} x = c_j \quad (j = 0, \dots, p-1) & \infty \\ [\lambda_{j,\nu} - (\delta_{j,0} + \delta_{j,1})\lambda_{j,n_j}]_{(m_{j,\nu})} & [\lambda_{p,\nu} + \lambda_{0,n_0} + \lambda_{1,n_1}]_{(m_{0,\nu})} \end{array} \right\} \\ &\xrightarrow{x^{\lambda_0, n_0} (1-x)^{\lambda_1, n_1}} \left\{ \begin{array}{cc} x = c_j & \infty \\ [\lambda_{j,\nu}]_{(m_{j,\nu})} & [\lambda_{p,\nu}]_{(m_{p,\nu})} \end{array} \right\} \\ &\xrightarrow{x^{-\lambda_0, 1} \prod_{j=1}^{p-1} (1-c_j^{-1}x)^{-\lambda_{j,1}}} \left\{ \begin{array}{cc} [0]_{(m_{j,1})} & [\lambda_{p,1} + \sum_{k=0}^{p-1} \lambda_{k,1}]_{(m_{p,1})} \\ [\lambda_{j,\nu} - \lambda_{j,1}]_{(m_{j,\nu})} & [\lambda_{p,\nu} + \sum_{k=0}^{p-1} \lambda_{k,1}]_{(m_{p,\nu})} \end{array} \right\} \\ &\xrightarrow{\partial^{1-\sum_{k=0}^p \lambda_{k,1}}} \left\{ \begin{array}{cc} [0]_{(m_{j,1-d})} & [\lambda_{p,1} + \sum_{k=0}^{p-1} \lambda_{k,1} - 2\lambda_1]_{(m_{p,1-d})} \\ [\lambda_{j,\nu} - \lambda_{j,1} + \lambda_1]_{(m_{j,\nu})} & [\lambda_{p,\nu} + \sum_{k=0}^{p-1} \lambda_{k,1} - \lambda_1]_{(m_{p,\nu})} \end{array} \right\} \\ &\quad (d = \sum_{k=0}^p m_{k,1} - (p-1)n) \end{aligned}$$

$$C_{\lambda_{0,n_1} - \lambda_{0,1}, \lambda_{1,n_1} - \lambda_{1,1}}^{\lambda_1} = \frac{x^{\lambda_{0,1}} \prod_{j=1}^{p-1} (1 - c_j^{-1} x)^{\lambda_{j,1}}}{\Gamma(\lambda_{0,n_0} + \lambda_1 - \lambda_{0,1} + 1) \Gamma(\lambda_{1,1} - \lambda_{1,n_1} - \lambda_1)} \rightarrow \left\{ \begin{array}{cc} x = \frac{1}{c_j} & \infty \\ [\lambda_{j,1}]_{(m_{j,1}-d)} & [\lambda_{p,1} - 2\lambda_1]_{(m_{p,1}-d)} \\ [\lambda_{j,\nu} + \lambda_1]_{(m_{j,\nu})} & [\lambda_{p,\nu} - \lambda_1]_{(m_{p,\nu})} \end{array} \right\},$$

In general, the following theorem is a direct consequence of Definition 7.6 and Lemma 14.2.

**Theorem 14.4.** *Put  $c_0 = \infty$ ,  $c_1 = 1$  and  $c_j \in \mathbb{C} \setminus \{0\}$  for  $j = 3, \dots, p-1$ . By the transformation*

$$\text{RAd}\left(x^{\lambda_{0,1}} \prod_{j=1}^{p-1} \left(1 - \frac{x}{c_j}\right)^{\lambda_{j,1}}\right) \circ \text{RAd}\left(\partial^{1 - \sum_{k=0}^p \lambda_{k,1}}\right) \circ \text{RAd}\left(x^{-\lambda_{0,1}} \prod_{j=1}^{p-1} \left(1 - \frac{x}{c_j}\right)^{-\lambda_{j,1}}\right)$$

the Riemann scheme of a Fuchsian ordinary differential equation and its connection coefficient change as follows:

$$\begin{aligned} \{\lambda_{\mathbf{m}}\} &= \left\{ [\lambda_{j,\nu}]_{(m_{j,\nu})} \right\}_{\substack{0 \leq j \leq p \\ 1 \leq \nu \leq n_j}} = \left\{ \begin{array}{cc} x = c_j & \infty \\ [\lambda_{j,1}]_{(m_{j,1})} & [\lambda_{p,1}]_{(m_{p,1})} \\ [\lambda_{j,\nu}]_{(m_{j,\nu})} & [\lambda_{p,\nu}]_{(m_{p,\nu})} \end{array} \right\} \\ \mapsto \{\lambda'_{\mathbf{m}'}\} &= \left\{ [\lambda'_{j,\nu}]_{(m'_{j,\nu})} \right\}_{\substack{0 \leq j \leq p \\ 1 \leq \nu \leq n_j}} \\ &= \left\{ \begin{array}{cc} x = c_j & \infty \\ [\lambda_{j,1}]_{(m_{j,1}-d)} & [\lambda_{p,1} - 2 \sum_{k=0}^p \lambda_{k,1} + 2]_{(m_{p,1}-d)} \\ [\lambda_{j,\nu} + \sum_{k=0}^p \lambda_{k,1} - 1]_{(m_{j,\nu})} & [\lambda_{p,\nu} - \sum_{k=0}^p \lambda_{k,1} + 1]_{(m_{p,\nu})} \end{array} \right\} \end{aligned}$$

with

$$\begin{aligned} d &= m_{0,1} + \dots + m_{p,1} - (p-1) \text{ord } \mathbf{m}, \\ m'_{j,\nu} &= m_{j,\nu} - d \delta_{\nu,1} \quad (j = 0, \dots, p, \nu = 1, \dots, n_j), \\ \lambda'_{j,1} &= \lambda_{j,1} \quad (j = 0, \dots, p-1), \quad \lambda'_{p,1} = -2\lambda_{0,1} - \dots - 2\lambda_{p-1,1} - \lambda_{p,1} + 2, \\ \lambda'_{j,\nu} &= \lambda_{j,\nu} + \lambda_{0,1} + \lambda_{1,1} + \dots + \lambda_{p,1} - 1 \quad (j = 0, \dots, p-1, \nu = 2, \dots, n_j), \\ \lambda'_{p,\nu} &= \lambda_{p,\nu} - \lambda_{0,1} - \dots - \lambda_{p,1} + 1 \end{aligned}$$

and if  $m_{0,n_0} = 1$  and  $n_0 > 1$  and  $n_1 > 1$ , then

$$(14.8) \quad \frac{c'(\lambda'_{0,n_0} \rightsquigarrow \lambda'_{1,n_1})}{\Gamma(\lambda'_{0,n_0} - \lambda'_{0,1} + 1) \Gamma(\lambda'_{1,1} - \lambda'_{1,n_1})} = \frac{c(\lambda_{0,n_0} \rightsquigarrow \lambda_{1,n_1})}{\Gamma(\lambda_{0,n_0} - \lambda_{0,1} + 1) \Gamma(\lambda_{1,1} - \lambda_{1,n_1})}.$$

Applying the successive reduction by  $\partial_{max}$  to the above theorem, we obtain the following theorem.

**Theorem 14.5.** *Suppose that a tuple  $\mathbf{m} \in \mathcal{P}$  is irreducibly realizable and  $m_{0,n_0} = m_{1,n_1} = 1$  in the Riemann scheme (14.1). Then the connection coefficient satisfies*

$$\begin{aligned} &\frac{c(\lambda_{0,n_0} \rightsquigarrow \lambda_{1,n_1})}{\bar{c}(\lambda(K)_{0,n_0} \rightsquigarrow \lambda(K)_{1,n_1})} \\ &= \prod_{k=0}^{K-1} \frac{\Gamma(\lambda(k)_{0,n_0} - \lambda(k)_{0,\ell(k)_0} + 1) \cdot \Gamma(\lambda(k)_{1,\ell(k)_1} - \lambda(k)_{1,n_1})}{\Gamma(\lambda(k+1)_{0,n_0} - \lambda(k+1)_{0,\ell(k)_0} + 1) \cdot \Gamma(\lambda(k+1)_{1,\ell(k)_1} - \lambda(k+1)_{1,n_1})} \end{aligned}$$



under the notation in Definitions 7.11. Here  $\bar{c}(\lambda(K)_{0,n_0} \rightsquigarrow \lambda(K)_{1,n_1})$  is a corresponding connection coefficient for the equation  $(\partial_{max}^K P_{\mathbf{m}})v = 0$  with the fundamental spectral type  $f\mathbf{m}$ . We note that

$$(14.9) \quad \begin{aligned} & (\lambda(k+1)_{0,n_0} - \lambda(k+1)_{0,\ell(k)_0} + 1) + (\lambda(k+1)_{1,\ell(k)_1} - \lambda(k+1)_{1,n_1}) \\ &= (\lambda(k)_{0,n_0} - \lambda(k)_{0,\ell(k)_0} + 1) + (\lambda(k)_{1,\ell(k)_1} - \lambda(k)_{1,n_1}) \end{aligned}$$

for  $k = 0, \dots, K-1$ .

When  $\mathbf{m}$  is rigid in the theorem above, we note that  $\bar{c}(\lambda_{0,n_0}(K) \rightsquigarrow \lambda_{1,n_1}(K)) = 1$  and we have the following more explicit result.

**Theorem 14.6.** *Let  $\mathbf{m} \in \mathcal{P}$  be a rigid tuple. Assume  $m_{0,n_0} = m_{1,n_1} = 1$ ,  $n_0 > 1$  and  $n_1 > 1$  in the Riemann scheme (14.1). Then*

$$(14.10) \quad c(\lambda_{0,n_0} \rightsquigarrow \lambda_{1,n_1}) = \frac{\prod_{\nu=1}^{n_0-1} \Gamma(\lambda_{0,n_0} - \lambda_{0,\nu} + 1) \cdot \prod_{\nu=1}^{n_1-1} \Gamma(\lambda_{1,\nu} - \lambda_{1,n_1})}{\prod_{\substack{\mathbf{m}' \oplus \mathbf{m}'' = \mathbf{m} \\ m'_{0,n_0} = m''_{1,n_1} = 1}} \Gamma(|\{\lambda_{\mathbf{m}'}\}|) \cdot \prod_{j=2}^{p-1} \left(1 - \frac{1}{c_j}\right)^{-\lambda(K)_{j,\ell(K)_j}},$$

$$(14.11) \quad \sum_{\substack{\mathbf{m}' \oplus \mathbf{m}'' = \mathbf{m} \\ m'_{0,n_0} = m''_{1,n_1} = 1}} m'_{j,\nu} = (n_1 - 1)m_{j,\nu} - \delta_{j,0}(1 - n_0\delta_{\nu,n_0}) + \delta_{j,1}(1 - n_1\delta_{\nu,n_1}) \\ (1 \leq \nu \leq n_j, 0 \leq j \leq p)$$

under the notation in Definitions 6.12 and 7.11.

*Proof.* We may assume  $\mathbf{m}$  is monotone and  $\text{ord } \mathbf{m} > 1$ .

We will prove this theorem by the induction on  $\text{ord } \mathbf{m}$ . Suppose

$$(14.12) \quad \mathbf{m} = \mathbf{m}' \oplus \mathbf{m}'' \quad \text{with} \quad m'_{0,n_0} = m''_{1,n_1} = 1.$$

If  $\partial_1 \mathbf{m}'$  is not well-defined, then

$$(14.13) \quad \text{ord } \mathbf{m}' = 1 \quad \text{and} \quad m'_{j,1} = 1 \quad \text{for} \quad j = 1, 2, \dots, p$$

and  $1 + m_{1,1} + \dots + m_{p,1} - (p-1) \text{ord } \mathbf{m} = 1$  because  $\text{idx}(\mathbf{m}, \mathbf{m}') = 1$  and therefore

$$(14.14) \quad d_1(\mathbf{m}) = m_{0,1}.$$

If  $\partial_1 \mathbf{m}''$  is not well-defined,

$$(14.15) \quad \text{ord } \mathbf{m}'' = 1 \quad \text{and} \quad m''_{j,1} = 1 \quad \text{for} \quad j = 0, 2, \dots, p, \\ d_1(\mathbf{m}) = m_{1,1}.$$

Hence if  $d_1(\mathbf{m}) < m_{0,1}$  and  $d_1(\mathbf{m}) < m_{1,1}$ ,  $\partial_1 \mathbf{m}'$  and  $\partial_1 \mathbf{m}''$  are always well-defined and  $\partial_1 \mathbf{m} = \partial_1 \mathbf{m}' \oplus \partial_1 \mathbf{m}''$  and the direct decompositions (14.12) of  $\mathbf{m}$  correspond to those of  $\partial_1 \mathbf{m}$  and therefore Theorem 14.4 shows (14.10) by the induction because we may assume  $d_1(\mathbf{m}) > 0$ . In fact, it follows from (7.15) that the gamma factors in the denominator of the fraction in the right hand side of (14.10) don't change by the reduction and the change of the numerator just corresponds to the formula in Theorem 14.4.

If  $d_1(\mathbf{m}) = m_{0,1}$ , there exists the direct decomposition (14.12) with (14.13) which doesn't correspond to a direct decomposition of  $\partial_1 \mathbf{m}$  but corresponds to the term  $\Gamma(|\{\lambda_{\mathbf{m}'}\}|) = \Gamma(\lambda_{0,n_1} + \lambda_{1,1} + \dots + \lambda_{p,1}) = \Gamma(\lambda'_{0,n_1} - \lambda'_{0,1} + 1)$  in (14.8). Similarly if  $d_1(\mathbf{m}) = m_{1,1}$ , there exists the direct decomposition (14.12) with (14.15) and it corresponds to the term  $\Gamma(|\{\lambda_{\mathbf{m}''}\}|) = \Gamma(1 - |\{\lambda_{\mathbf{m}''}\}|) = \Gamma(1 - \lambda_{0,1} - \lambda_{1,n_1} - \lambda_{2,1} - \dots - \lambda_{p,1}) = \Gamma(\lambda'_{1,1} - \lambda'_{1,n_1})$  (cf. (14.21)). Thus Theorem 14.4 assures (14.10) by the induction on  $\text{ord } \mathbf{m}$ .

Note that the above proof with (14.9) shows (14.18). Hence

$$\begin{aligned}
\sum_{\substack{\mathbf{m}' \oplus \mathbf{m}'' = \mathbf{m} \\ m'_{0,n_0} = m''_{1,n_1} = 1}} |\{\lambda_{\mathbf{m}}\}| &= \sum_{\nu=1}^{n_0-1} (\lambda_{0,n_0} - \lambda_{0,\nu} + 1) + \sum_{\nu=1}^{n_1-1} (\lambda_{1,\nu} - \lambda_{1,n_1}) \\
&= (n_0 - 1) + (n_0 - 1)\lambda_{0,n_0} - \sum_{\nu=1}^{n_0-1} \lambda_{0,\nu} + \sum_{\nu=1}^{n_1-1} \lambda_{1,\nu} \\
&\quad + (n_1 - 1) \left( \sum_{j=0}^p \sum_{\nu=1}^{n_j - \delta_{j,1}} m_{j,\nu} \lambda_{j,\nu} - n + 1 \right) \\
&= (n_0 + n_1 - 2)\lambda_{0,n_0} + \sum_{\nu=1}^{n_0-1} ((n_1 - 1)m_{0,\nu} - 1)\lambda_{0,\nu} \\
&\quad + \sum_{\nu=1}^{n_1-1} ((n_1 - 1)m_{1,\nu} + 1)\lambda_{1,\nu} + \sum_{j=2}^p \sum_{\nu=1}^{n_2} (n_1 - 1)m_{j,\nu} \lambda_{j,\nu} \\
&\quad + (n_0 + n_1 - 2) - (n_1 - 1) \text{ord } \mathbf{m}.
\end{aligned}$$

The left hand side of the above first equation and the right hand side of the above last equation don't contain the term  $\lambda_{1,n_1}$  and therefore the coefficients of  $\lambda_{j,\nu}$  in the both sides are equal, which implies (14.11).  $\square$

**Corollary 14.7.** *Retain the notation in Theorem 14.6. We have*

$$(14.16) \quad \#\{\mathbf{m}'; \mathbf{m}' \oplus \mathbf{m}'' = \mathbf{m} \text{ with } m'_{0,n_0} = m''_{1,n_1} = 1\} = n_0 + n_1 - 2,$$

$$(14.17) \quad \sum_{\substack{\mathbf{m}' \oplus \mathbf{m}'' = \mathbf{m} \\ m'_{0,n_0} = m''_{1,n_1} = 1}} \text{ord } \mathbf{m}' = (n_1 - 1) \text{ord } \mathbf{m},$$

$$(14.18) \quad \sum_{\substack{\mathbf{m}' \oplus \mathbf{m}'' = \mathbf{m} \\ m'_{0,n_0} = m''_{1,n_1} = 1}} |\{\lambda'_{\mathbf{m}}\}| = \sum_{\nu=1}^{n_0-1} (\lambda_{0,n_0} - \lambda_{0,\nu} + 1) + \sum_{\nu=1}^{n_1-1} (\lambda_{1,\nu} - \lambda_{1,n_1}).$$

Let  $c(\lambda_{0,n_0} + t \rightsquigarrow \lambda_{1,n_1} - t)$  be the connection coefficient for the Riemann scheme  $\{\lambda_{j,\nu} + t(\delta_{j,0}\delta_{\nu,n_0} - \delta_{j,1}\delta_{\nu,n_1})\}_{(m_{j,\nu})}$ . Then

$$(14.19) \quad \lim_{t \rightarrow +\infty} c(0: \lambda_{0,n_0} + t \rightsquigarrow 1: \lambda_{1,n_1} - t) = \prod_{j=2}^{p-1} (1 - c_j)^{\lambda^{(K)}_{j,\ell(K)_j}}.$$

Under the notation in Theorem 12.13

$$(14.20) \quad \begin{aligned} &\{\mathbf{m}'; \mathbf{m}' \oplus \mathbf{m}'' = \mathbf{m} \text{ with } m'_{0,n_0} = m''_{1,n_1} = 1\} \\ &= \{\mathbf{m}' \in \mathcal{P}; m'_{0,n_0} = 1, m'_{1,n_1} = 0, \alpha_{\mathbf{m}'} \text{ or } \alpha_{\mathbf{m}-\mathbf{m}'} \in \Delta(\mathbf{m})\}. \end{aligned}$$

*Proof.* We have (14.18) in the proof of Theorem 14.4 and then Stirling's formula and (14.18) prove (14.19). Putting  $(j, \nu) = (0, n_0)$  in (14.11) and considering the sum  $\sum_{\nu}$  for (14.11) with  $j = 1$ , we have (14.16) and (14.17), respectively.

Comparing the proof of Theorem 14.6 with that of Theorem 12.13, we have (14.20). Proposition 9.9 also proves (14.20).  $\square$

*Remark 14.8.* i) When we calculate a connection coefficient for a given rigid partition  $\mathbf{m}$  by (14.10), it is necessary to get all the direct decompositions  $\mathbf{m} = \mathbf{m}' \oplus \mathbf{m}''$  satisfying  $m'_{0,n_0} = m''_{1,n_1} = 1$ . In this case the equality (14.16) is useful because we know that the number of such decompositions equals  $n_0 + n_1 - 2$ , namely, the number of gamma functions appearing in the numerator equals that appearing in the denominator in (14.10).

ii) A direct decomposition  $\mathbf{m} = \mathbf{m}' \oplus \mathbf{m}''$  for a rigid tuple  $\mathbf{m}$  means that  $\{\alpha_{\mathbf{m}'}, \alpha_{\mathbf{m}''}\}$  is a fundamental system of a root system of type  $A_2$  in  $\mathbb{R}\alpha_{\mathbf{m}'} + \mathbb{R}\alpha_{\mathbf{m}''}$  such that  $\alpha_{\mathbf{m}} = \alpha_{\mathbf{m}'} + \alpha_{\mathbf{m}''}$  and

$$\begin{cases} (\alpha_{\mathbf{m}'} | \alpha_{\mathbf{m}'}) = (\alpha_{\mathbf{m}''} | \alpha_{\mathbf{m}''}) = 2, \\ (\alpha_{\mathbf{m}'} | \alpha_{\mathbf{m}''}) = -1. \end{cases}$$

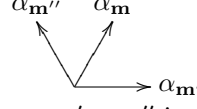

iii) In view of Definition 6.12, the condition  $\mathbf{m} = \mathbf{m}' \oplus \mathbf{m}''$  in (14.10) means

$$(14.21) \quad |\{\lambda_{\mathbf{m}'}\}| + |\{\lambda_{\mathbf{m}''}\}| = 1.$$

Hence we have

$$(14.22) \quad \begin{aligned} & c(\lambda_{0,n_0} \rightsquigarrow \lambda_{1,n_1}) \cdot c(\lambda_{1,n_1} \rightsquigarrow \lambda_{0,n_0}) \\ & \prod_{\substack{\mathbf{m}' \oplus \mathbf{m}'' = \mathbf{m} \\ m'_{0,n_0} = m''_{1,n_1} = 1}} \sin(|\{\lambda_{\mathbf{m}'}\}| \pi) \\ &= \frac{\prod_{\nu=1}^{n_0-1} \sin(\lambda_{0,\nu} - \lambda_{1,\nu}) \pi \cdot \prod_{\nu=1}^{n_1-1} \sin(\lambda_{1,\nu} - \lambda_{0,\nu}) \pi}{\prod_{\nu=1}^{n_0-1} \sin(\lambda_{0,\nu} - \lambda_{1,\nu}) \pi \cdot \prod_{\nu=1}^{n_1-1} \sin(\lambda_{1,\nu} - \lambda_{0,\nu}) \pi}. \end{aligned}$$

iv) By the aid of a computer, the author obtained the table of the concrete connection coefficients (14.10) for the rigid triplets  $\mathbf{m}$  satisfying  $\text{ord } \mathbf{m} \leq 40$  together with checking (14.11), which contains 4,111,704 independent cases (cf. §15.11).

**14.2. An estimate for large exponents.** The Gauss hypergeometric series

$$F(\alpha, \beta, \gamma; x) := \sum_{k=0}^{\infty} \frac{\alpha(\alpha+1) \cdots (\alpha+k-1) \cdot \beta(\beta+1) \cdots (\beta+k-1)}{\gamma(\gamma+1) \cdots (\gamma+k-1) \cdot k!} x^k$$

uniformly and absolutely converges for

$$(14.23) \quad x \in \bar{D} := \{x \in \mathbb{C}; |x| \leq 1\}$$

if  $\text{Re } \gamma > \text{Re}(\alpha + \beta)$  and defines a continuous function on  $\bar{D}$ . The continuous function  $F(\alpha, \beta, \gamma + n; x)$  on  $\bar{D}$  uniformly converges to the constant function 1 when  $n \rightarrow +\infty$ , which obviously implies

$$(14.24) \quad \lim_{n \rightarrow \infty} F(\alpha, \beta, \gamma + n; 1) = 1$$

and proves Gauss's summation formula (1.3) by using the recurrence relation

$$(14.25) \quad \frac{F(\alpha, \beta, \gamma; 1)}{F(\alpha, \beta, \gamma + 1; 1)} = \frac{(\gamma - \alpha)(\gamma - \beta)}{\gamma(\gamma - \alpha - \beta)}.$$

We will generalize such convergence in a general system of ordinary differential equations of Schlesinger canonical form.

Under the condition

$$a > 0, \quad b > 0 \quad \text{and} \quad c > a + b,$$

the function  $F(a, b, c; x) = \sum_{k=0}^{\infty} \frac{(a)_k (b)_k}{(c)_k k!} x^k$  is strictly increasing continuous function of  $x \in [0, 1]$  satisfying

$$1 \leq F(a, b, c; x) \leq F(a, b, c; 1) = \frac{\Gamma(c)\Gamma(c-a-b)}{\Gamma(c-a)\Gamma(c-b)}$$

and it increases if  $a$  or  $b$  or  $-c$  increases. In particular, if

$$0 \leq a \leq N, \quad 0 \leq b \leq N \quad \text{and} \quad c > 2N$$

with a positive integer  $N$ , we have

$$\begin{aligned}
0 &\leq F(a, b, c; x) - 1 \\
&\leq \frac{\Gamma(c)\Gamma(c-2N)}{\Gamma(c-N)\Gamma(c-N)} - 1 = \frac{(c-N)_N}{(c-2N)_N} - 1 = \prod_{\nu=1}^N \frac{c-\nu}{c-N-\nu} - 1 \\
&\leq \left(\frac{c-N}{c-2N}\right)^N - 1 = \left(1 + \frac{N}{c-2N}\right)^N - 1 \\
&\leq N \left(1 + \frac{N}{c-2N}\right)^{N-1} \frac{N}{c-2N}.
\end{aligned}$$

Thus we have the following lemma.

**Lemma 14.9.** *For a positive integer  $N$  we have*

$$(14.26) \quad |F(\alpha, \beta, \gamma; x) - 1| \leq \left(1 + \frac{N}{\operatorname{Re} \gamma - 2N}\right)^N - 1$$

if

$$(14.27) \quad x \in \bar{D}, \quad |\alpha| \leq N, \quad |\beta| \leq N \quad \text{and} \quad \operatorname{Re} \gamma > 2N.$$

*Proof.* The lemma is clear because

$$\left| \sum_{k=1}^{\infty} \frac{(\alpha)_k (\beta)_k}{(\gamma)_k k!} x^k \right| \leq \sum_{k=1}^{\infty} \frac{(|\alpha|)_k (|\beta|)_k}{(\operatorname{Re} \gamma)_k k!} |x|^k = F(|\alpha|, |\beta|, \operatorname{Re} \gamma - 2N; |x|) - 1 \quad \square$$

For the Gauss hypergeometric equation

$$x(1-x)u'' + (\gamma - (\alpha + \beta + 1)x)u' - \alpha\beta u = 0$$

we have

$$\begin{aligned}
(xu')' &= u' + xu'' = \frac{xu'}{x} + \frac{((\alpha + \beta + 1)x - \gamma)u' + \alpha\beta u}{1-x} \\
&= \frac{\alpha\beta}{1-x}u + \left(\frac{1}{x} - \frac{\gamma}{x(1-x)} + \frac{\alpha + \beta + 1}{1-x}\right)xu' \\
&= \frac{\alpha\beta}{1-x}u + \left(\frac{1-\gamma}{x} + \frac{\alpha + \beta - \gamma + 1}{1-x}\right)xu'.
\end{aligned}$$

Putting

$$(14.28) \quad \tilde{u} = \begin{pmatrix} u_0 \\ u_1 \end{pmatrix} := \begin{pmatrix} u \\ \frac{xu'}{\alpha} \end{pmatrix}$$

we have

$$(14.29) \quad \tilde{u}' = \frac{\begin{pmatrix} 0 & \alpha \\ 0 & 1-\gamma \end{pmatrix}}{x} \tilde{u} + \frac{\begin{pmatrix} 0 & 0 \\ \beta & \alpha + \beta - \gamma + 1 \end{pmatrix}}{1-x} \tilde{u}.$$

In general for

$$v' = \frac{A}{x}v + \frac{B}{1-x}v$$

we have

$$\begin{aligned}
xv' &= Av + \frac{x}{1-x}Bv \\
&= Av + x(xv' + (B-A)v).
\end{aligned}$$

Thus

$$(14.30) \quad \begin{cases} xu'_0 = \alpha u_1, \\ xu'_1 = (1 - \gamma)u_1 + x(xu'_1 + \beta u_0 + (\alpha + \beta)u_1) \end{cases}$$

and the functions

$$(14.31) \quad \begin{cases} u_0 = F(\alpha, \beta, \gamma; x), \\ u_1 = \frac{\beta x}{\gamma} F(\alpha + 1, \beta + 1, \gamma + 1; x) \end{cases}$$

satisfies (14.30).

**Theorem 14.10.** *Let  $n$ ,  $n_0$  and  $n_1$  be positive integers satisfying  $n = n_0 + n_1$  and let  $A = \begin{pmatrix} 0 & A_0 \\ 0 & A_1 \end{pmatrix}$ ,  $B = \begin{pmatrix} 0 & 0 \\ B_0 & B_1 \end{pmatrix} \in M(n, \mathbb{C})$  such that  $A_1, B_1 \in M(n_1, \mathbb{C})$ ,  $A_0 \in M(n_0, n_1, \mathbb{C})$  and  $B_0 \in M(n_1, n_0, \mathbb{C})$ . Let  $D(\mathbf{0}, \mathbf{m}) = D(\mathbf{0}, m_1, \dots, m_{n_1})$  be the diagonal matrix of size  $n$  whose  $k$ -th diagonal element is  $m_{k-n_0}$  if  $k > n_0$  and 0 otherwise. Let  $u^{\mathbf{m}}$  be the local holomorphic solution of*

$$(14.32) \quad u = \frac{A - D(\mathbf{0}, \mathbf{m})}{x} u + \frac{B - D(\mathbf{0}, \mathbf{m})}{1 - x} u$$

at the origin. Then if  $\operatorname{Re} m_\nu$  are sufficiently large for  $\nu = 1, \dots, n_1$ , the Taylor series of  $u^{\mathbf{m}}$  at the origin uniformly converge on  $\bar{D} = \{x \in \mathbb{C}; |x| \leq 1\}$  and for a positive number  $C$ , the function  $u^{\mathbf{m}}$  and their derivatives uniformly converge to constants on  $\bar{D}$  when  $\min\{\operatorname{Re} m_1, \dots, \operatorname{Re} m_{n_1}\} \rightarrow +\infty$  with  $|A_{ij}| + |B_{ij}| \leq C$ . In particular, for  $x \in \bar{D}$  and an integer  $N$  satisfying

$$(14.33) \quad \sum_{\nu=1}^{n_1} |(A_0)_{i\nu}| \leq N, \quad \sum_{\nu=1}^{n_1} |(A_1)_{i\nu}| \leq N, \quad \sum_{\nu=1}^{n_0} |(B_0)_{i\nu}| \leq N, \quad \sum_{\nu=1}^{n_1} |(B_1)_{i\nu}| \leq N$$

we have

$$(14.34) \quad \max_{1 \leq \nu \leq n} |u_\nu^{\mathbf{m}}(x) - u_\nu^{\mathbf{m}}(0)| \leq \max_{1 \leq \nu \leq n_0} |u_\nu^{\mathbf{m}}(0)| \cdot \frac{2^N (N+1)^2}{\min_{1 \leq \nu \leq n_1} \operatorname{Re} m_\nu - 4N - 1}$$

if  $\operatorname{Re} m_\nu > 5N + 4$  for  $\nu = 1, \dots, n_1$ .

*Proof.* Use the method of majorant series and compare to the case of Gauss hypergeometric series (cf. (14.30) and (14.31)), namely,  $\lim_{c \rightarrow +\infty} F(a, b, c; x) = 1$  on  $\bar{D}$  with a solution of the Fuchsian system

$$\begin{aligned} u' &= \frac{A}{x} u + \frac{B}{1-x} u, \\ A &= \begin{pmatrix} 0 & A_0 \\ 0 & A_1 \end{pmatrix}, \quad B = \begin{pmatrix} 0 & 0 \\ B_0 & B_1 \end{pmatrix}, \quad u = \begin{pmatrix} v_0 \\ v_1 \end{pmatrix}, \\ xv'_0 &= A_0 v_1, \\ xv'_1 &= x^2 v'_1 + (1-x)A_1 v_1 + xB_0 v_0 + xB_1 v_1 \\ &= A_1 v_1 + x(xv'_1 + B_0 v_0 + (B_1 - A_1)v_1) \end{aligned}$$

or the system obtained by the substitution  $A_1 \mapsto A_1 - D(\mathbf{m})$  and  $B_1 \mapsto B_1 - D(\mathbf{m})$ . Fix positive real numbers  $\alpha$ ,  $\beta$  and  $\gamma$  satisfying

$$\begin{aligned} \alpha &\geq \sum_{\nu=1}^{n_1} |(A_0)_{i\nu}| \quad (1 \leq i \leq n_0), \quad \beta \geq \sum_{\nu=1}^{n_0} |(B_0)_{i\nu}| \quad (1 \leq i \leq n_1), \\ \alpha + \beta &\geq \sum_{\nu=1}^{n_1} |(B_1 - A_1)_{i\nu}| \quad (1 \leq i \leq n_0), \\ \gamma &= \min\{\operatorname{Re} m_1, \dots, \operatorname{Re} m_{n_1}\} - 2 \max_{1 \leq i \leq n_1} \sum_{\nu=1}^{n_1} |(A_1)_{i\nu}| - 1 > \alpha + \beta. \end{aligned}$$

Then the method of majorant series with Lemma 14.11, (14.30) and (14.31) imply

$$u_i^{\mathbf{m}} \ll \begin{cases} \max_{1 \leq \nu \leq n_0} |u_\nu^{\mathbf{m}}(0)| \cdot F(\alpha, \beta, \gamma; x) & (1 \leq i \leq n_0), \\ \frac{\beta}{\gamma} \cdot \max_{1 \leq \nu \leq n_0} |u_\nu^{\mathbf{m}}(0)| \cdot F(\alpha + 1, \beta + 1, \gamma + 1; x) & (n_0 < i \leq n), \end{cases}$$

which proves the theorem because of Lemma 14.9 with  $\alpha = \beta = N$  as follows. Here  $\sum_{\nu=0}^{\infty} a_\nu x^\nu \ll \sum_{\nu=0}^{\infty} b_\nu x^\nu$  for formal power series means  $|a_\nu| \leq b_\nu$  for  $\nu \in \mathbb{Z}_{\geq 0}$ .

Put  $\bar{m} = \min\{\operatorname{Re} m_1, \dots, \operatorname{Re} m_{n_1}\} - 2N - 1$  and  $L = \max_{1 \leq \nu \leq n_0} |u_\nu^{\mathbf{m}}(0)|$ . Then  $\gamma \geq \bar{m} - 2N - 1$  and if  $0 \leq i \leq n_0$  and  $x \leq \bar{D}$ ,

$$\begin{aligned} |u_i^{\mathbf{m}}(x) - u_i^{\mathbf{m}}(0)| &\leq L \cdot (F(\alpha, \beta, \gamma; |x|) - 1) \\ &\leq L \left( \left( 1 + \frac{N}{\bar{m} - 4N - 1} \right)^N - 1 \right) \\ &\leq L \left( 1 + \frac{N}{\bar{m} - 4N - 1} \right)^{N-1} \frac{N^2}{\bar{m} - 4N - 1} \leq \frac{L 2^{N-1} N^2}{\bar{m} - 4N - 1}. \end{aligned}$$

If  $n_0 < i \leq n$  and  $x \in \bar{D}$ ,

$$\begin{aligned} |u_i^{\mathbf{m}}(x)| &\leq \frac{\beta}{\gamma} \cdot LF(\alpha + 1, \beta + 1, \gamma + 1; |x|) \\ &\leq \frac{LN}{\bar{m} - 2N - 1} \left( \left( 1 + \frac{N+1}{\bar{m} - 4N - 3} \right)^{N+1} + 1 \right) \leq \frac{LN(2^{N+1} + 1)}{\bar{m} - 2N - 1}. \quad \square \end{aligned}$$

**Lemma 14.11.** *Let  $A \in M(n, \mathbb{L})$  and put*

$$(14.35) \quad |A| := \max_{1 \leq i \leq n} \sum_{\nu=1}^n |A_{i\nu}|.$$

*If positive real numbers  $m_1, \dots, m_n$  satisfy*

$$(14.36) \quad m_{\min} := \min\{m_1, \dots, m_n\} > 2|A|,$$

*we have*

$$(14.37) \quad |(kI_n + D(\mathbf{m}) - A)^{-1}| \leq (k + m_{\min} - 2|A|)^{-1} \quad (\forall k \geq 0).$$

*Proof.* Since

$$\begin{aligned} |(D(\mathbf{m}) - A)^{-1}| &= |D(\mathbf{m})^{-1}(I_n - D(\mathbf{m})^{-1}A)^{-1}| \\ &= \left| D(\mathbf{m})^{-1} \sum_{k=0}^{\infty} (D(\mathbf{m})^{-1}A)^k \right| \\ &\leq m_{\min}^{-1} \cdot \left( 1 + \frac{2|A|}{m_{\min}} \right) \leq (m_{\min} - 2|A|)^{-1}, \end{aligned}$$

we have the lemma by replacing  $m_\nu$  by  $m_\nu + k$  for  $\nu = 1, \dots, n$ . □

**14.3. Zeros and poles of connection coefficients.** In this subsection we examine the connection coefficients to calculate them in a different way from the one given in §14.1.

First review the connection coefficient  $c(0: \lambda_{0,2} \rightsquigarrow 1: \lambda_{1,2})$  for the solution of Fuchsian differential equation with the Riemann scheme  $\left\{ \begin{array}{ccc} x = 0 & 1 & \infty \\ \lambda_{0,1} & \lambda_{1,1} & \lambda_{2,1} \\ \lambda_{0,2} & \lambda_{1,2} & \lambda_{2,2} \end{array} \right\}$ . Denoting the connection coefficient  $c(0: \lambda_{0,2} \rightsquigarrow 1: \lambda_{1,2})$  by  $c\left(\left\{ \begin{array}{ccc} \lambda_{0,1} & \lambda_{1,1} & \lambda_{2,1} \\ \lambda_{0,2} \rightsquigarrow & \lambda_{1,2} & \lambda_{2,2} \end{array} \right\}\right)$ , we have

$$(14.38) \quad u_0^{\lambda_{0,2}} = c\left(\left\{ \begin{array}{ccc} \lambda_{0,1} & \lambda_{1,1} & \lambda_{2,1} \\ \lambda_{0,2} \rightsquigarrow & \lambda_{1,2} & \lambda_{2,2} \end{array} \right\}\right) u_1^{\lambda_{1,2}} + c\left(\left\{ \begin{array}{ccc} \lambda_{0,1} & \lambda_{1,2} & \lambda_{2,1} \\ \lambda_{0,2} \rightsquigarrow & \lambda_{1,1} & \lambda_{2,2} \end{array} \right\}\right) u_1^{\lambda_{1,1}}.$$

$$(14.39) \quad c\left(\left\{ \begin{array}{ccc} \lambda_{0,1} & \lambda_{1,1} & \lambda_{2,1} \\ \lambda_{0,2} \rightsquigarrow & \lambda_{1,2} & \lambda_{2,2} \end{array} \right\}\right) = c\left(\left\{ \begin{array}{ccc} \lambda_{0,1} - \lambda_{0,2} & \lambda_{1,1} - \lambda_{1,2} & \lambda_{0,2} + \lambda_{1,2} + \lambda_{2,1} \\ 0 & 0 & \lambda_{0,2} + \lambda_{1,2} + \lambda_{2,2} \end{array} \right\}\right) \\ = F(\lambda_{0,2} + \lambda_{1,2} + \lambda_{2,1}, \lambda_{0,2} + \lambda_{1,2} + \lambda_{2,2}, \lambda_{0,2} - \lambda_{0,1} + 1; 1)$$

under the notation in Definition 14.1. As was explained in the first part of §14.2, the connection coefficient is calculated from

$$(14.40) \quad \lim_{n \rightarrow \infty} c\left(\left\{ \begin{array}{ccc} \lambda_{0,1} - n & \lambda_{1,1} + n & \lambda_{2,1} \\ \lambda_{0,2} \rightsquigarrow & \lambda_{1,2} & \lambda_{2,2} \end{array} \right\}\right) = 1$$

and

$$(14.41) \quad \frac{c\left(\left\{ \begin{array}{ccc} \lambda_{0,1} & \lambda_{1,1} & \lambda_{2,1} \\ \lambda_{0,2} \rightsquigarrow & \lambda_{1,2} & \lambda_{2,2} \end{array} \right\}\right)}{c\left(\left\{ \begin{array}{ccc} \lambda_{0,1} - 1 & \lambda_{1,1} + 1 & \lambda_{2,1} \\ \lambda_{0,2} \rightsquigarrow & \lambda_{1,2} & \lambda_{2,2} \end{array} \right\}\right)} = \frac{(\lambda_{0,2} + \lambda_{1,1} + \lambda_{2,2})(\lambda_{0,2} + \lambda_{1,1} + \lambda_{2,1})}{(\lambda_{0,2} - \lambda_{0,1} + 1)(\lambda_{1,1} - \lambda_{1,2})}.$$

The relation (14.40) is easily obtained from (14.39) and (14.24) or can be reduced to Theorem 14.10.

We will examine (14.41). For example, the relation (14.41) follows from the relation (14.25) which is obtained from

$$\gamma(\gamma - 1 - (2\gamma - \alpha - \beta - 1)x)F(\alpha, \beta, \gamma; x) + (\gamma - \alpha)(\gamma - \beta)xF(\alpha, \beta, \gamma + 1; x) \\ = \gamma(\gamma - 1)(1 - x)F(\alpha, \beta, \gamma - 1; x)$$

by putting  $x = 1$  (cf. [WW, §14.1]). We may use a shift operator as follows. Since

$$\frac{d}{dx}F(\alpha, \beta, \gamma; x) = \frac{\alpha\beta}{\gamma}F(\alpha + 1, \beta + 1, \gamma + 1; x) \\ = c\left(\left\{ \begin{array}{ccc} 1 - \gamma & \gamma - \alpha - \beta & \alpha \\ 0 & 0 & \beta \end{array} \right\}\right) \frac{d}{dx}u_1^0 + c\left(\left\{ \begin{array}{ccc} 1 - \gamma & 0 & \alpha \\ 0 & \gamma - \alpha - \beta & \beta \end{array} \right\}\right) \frac{d}{dx}u_1^{\gamma - \alpha - \beta}$$

and

$$\frac{d}{dx}u_1^{\gamma - \alpha - \beta} \equiv (\alpha + \beta - \gamma)(1 - x)^{\gamma - \alpha - \beta - 1} \pmod{(1 - x)^{\gamma - \alpha - \beta} \mathcal{O}_1},$$

we have

$$\frac{\alpha\beta}{\gamma}c\left(\left\{ \begin{array}{ccc} -\gamma & 0 & \alpha + 1 \\ 0 & \gamma - \alpha - \beta - 1 & \beta + 1 \end{array} \right\}\right) = (\alpha + \beta - \gamma)c\left(\left\{ \begin{array}{ccc} 1 - \gamma & 0 & \alpha \\ 0 & \gamma - \alpha - \beta & \beta \end{array} \right\}\right),$$

which also proves (14.41) because

$$\frac{c\left(\left\{ \begin{array}{ccc} \lambda_{0,1} & \lambda_{1,1} & \lambda_{2,1} \\ \lambda_{0,2} \rightsquigarrow & \lambda_{1,2} & \lambda_{2,2} \end{array} \right\}\right)}{c\left(\left\{ \begin{array}{ccc} \lambda_{0,1} - 1 & \lambda_{1,1} + 1 & \lambda_{2,1} \\ \lambda_{0,2} \rightsquigarrow & \lambda_{1,2} & \lambda_{2,2} \end{array} \right\}\right)} = \frac{c\left(\left\{ \begin{array}{ccc} \lambda_{0,1} - \lambda_{0,2} & 0 & \lambda_{0,2} + \lambda_{1,1} + \lambda_{2,1} \\ 0 & \rightsquigarrow \lambda_{1,2} - \lambda_{1,1} & \lambda_{0,2} + \lambda_{1,1} + \lambda_{2,2} \end{array} \right\}\right)}{c\left(\left\{ \begin{array}{ccc} \lambda_{0,1} - \lambda_{0,2} - 1 & 0 & \lambda_{0,2} + \lambda_{1,2} + \lambda_{2,1} + 1 \\ 0 & \rightsquigarrow \lambda_{1,2} - \lambda_{1,1} - 1 & \lambda_{0,2} + \lambda_{1,2} + \lambda_{2,2} + 1 \end{array} \right\}\right)}.$$

Furthermore each linear term appeared in the right hand side of (14.41) has own meaning, which is as follows.

Examine the zeros and poles of the connection coefficient  $c\left(\left\{ \begin{array}{ccc} \lambda_{0,1} & \lambda_{1,1} & \lambda_{2,1} \\ \lambda_{0,2} \rightsquigarrow & \lambda_{1,2} & \lambda_{2,2} \end{array} \right\}\right)$ . We may assume that the parameters  $\lambda_{j,\nu}$  are generic in the zeros or the poles.

Consider the linear form  $\lambda_{0,2} + \lambda_{1,1} + \lambda_{2,2}$ . The local solution  $u_0^{\lambda_{0,2}}$  corresponding to the characteristic exponent  $\lambda_{0,2}$  at 0 satisfies a Fuchsian differential equation of order 1 which has the characteristic exponents  $\lambda_{2,2}$  and  $\lambda_{1,1}$  at  $\infty$  and 1, respectively, if and only if the value of the linear form is 0 or a negative integer. In this case  $c(\left\{ \begin{smallmatrix} \lambda_{0,1} & \lambda_{1,1} & \lambda_{2,1} \\ \lambda_{0,2} & \rightsquigarrow & \lambda_{1,2} & \lambda_{2,2} \end{smallmatrix} \right\})$  vanishes. This explains the term  $\lambda_{0,2} + \lambda_{1,1} + \lambda_{2,2}$  in the numerator of the right hand side of (14.41). The term  $\lambda_{0,2} + \lambda_{1,2} + \lambda_{2,2}$  is similarly explained.

The normalized local solution  $u_0^{\lambda_{0,2}}$  has poles where  $\lambda_{0,1} - \lambda_{0,2}$  is a positive integer. The residue at the pole is a local solution corresponding to the exponent  $\lambda_{0,2}$ . This means that  $c(\left\{ \begin{smallmatrix} \lambda_{0,1} & \lambda_{1,1} & \lambda_{2,1} \\ \lambda_{0,2} & \rightsquigarrow & \lambda_{1,2} & \lambda_{2,2} \end{smallmatrix} \right\})$  has poles where  $\lambda_{0,1} - \lambda_{0,2}$  is a positive integer, which explains the term  $\lambda_{0,2} - \lambda_{0,1} + 1$  in the denominator of the right hand side of (14.41).

There exists a local solution  $a(\lambda)u_1^{\lambda_{1,1}} + b(\lambda)u_1^{\lambda_{1,2}}$  such that it is holomorphic for  $\lambda_{j,\nu}$  and  $b(\lambda)$  has a pole if the value of  $\lambda_{1,1} - \lambda_{1,2}$  is a non-negative integer, which means  $c(\left\{ \begin{smallmatrix} \lambda_{0,1} & \lambda_{1,1} & \lambda_{2,1} \\ \lambda_{0,2} & \rightsquigarrow & \lambda_{1,2} & \lambda_{2,2} \end{smallmatrix} \right\})$  has poles where  $\lambda_{1,2} - \lambda_{1,1}$  is non-negative integer. This explains the term  $\lambda_{1,1} - \lambda_{1,2}$  in the denominator of the right hand side of (14.41). These arguments can be generalized, which will be explained in this subsection.

First we examine the possible poles of connection coefficients.

**Proposition 14.12.** *Let  $Pu = 0$  be a differential equation of order  $n$  with a regular singularity at  $x = 0$  such that  $P$  contains a holomorphic parameter  $\lambda = (\lambda_1, \dots, \lambda_N)$  defined in a neighborhood of  $\lambda^o = (\lambda_1^o, \dots, \lambda_N^o)$  in  $\mathbb{C}^N$ . Suppose that the set of characteristic exponents of  $P$  at  $x = 0$  equals  $\{[\lambda_1]_{(m_1)}, \dots, [\lambda_N]_{(m_N)}\}$  with  $n = m_1 + \dots + m_N$  and*

$$(14.42) \quad \lambda_{2,1}^o := \lambda_2^o - \lambda_1^o \in \mathbb{Z}_{\geq 0} \text{ and } \lambda_i^o - \lambda_j^o \notin \mathbb{Z} \text{ if } 1 \leq i < j \leq N \text{ and } j \neq 2.$$

Let  $u_{j,\nu}$  be local solutions of  $Pu = 0$  uniquely defined by

$$(14.43) \quad u_{j,\nu} \equiv x^{\lambda_j + \nu} \pmod{x^{\lambda_j + m_j} \mathcal{O}_0} \quad (j = 1, \dots, m_j \text{ and } \nu = 0, \dots, m_j - 1).$$

Note that  $u_{j,\nu} = \sum_{k \geq 0} a_{k,j,\nu}(\lambda) x^{\lambda_j + \nu + k}$  with meromorphic functions  $a_{k,j,\nu}(\lambda)$  of  $\lambda$  which are holomorphic in a neighborhood of  $\lambda^o$  if  $\lambda_2 - \lambda_1 \neq \lambda_{2,1}^o$ . Then there exist solutions  $v_{j,\nu}$  with holomorphic parameter  $\lambda$  in a neighborhood of  $\lambda^o$  which satisfy the following relations. Namely

$$(14.44) \quad v_{j,\nu} = u_{j,\nu} \quad (3 \leq j \leq N \text{ and } \nu = 0, \dots, m_j - 1)$$

and when  $\lambda_1^o + m_1 \geq \lambda_2^o + m_2$ ,

$$(14.45) \quad v_{1,\nu} = u_{1,\nu} \quad (0 \leq \nu < m_1),$$

$$v_{2,\nu} = \frac{u_{2,\nu} - u_{1,\nu + \lambda_{2,1}^o}}{\lambda_1 - \lambda_2 + \lambda_{2,1}^o} - \sum_{m_2 + \lambda_{2,1}^o \leq i < m_1} \frac{b_{\nu,i} u_{1,i}}{\lambda_1 - \lambda_2 + \lambda_{2,1}^o} \quad (0 \leq \nu < m_2)$$

with the diagram

$$\begin{array}{ccccccc} \lambda_1^o & \lambda_1^o + 1 & \dots & \lambda_1^o + \lambda_{2,1}^o & \lambda_1^o + \lambda_{2,1}^o + m_2 - 1 & \lambda_1^o + m_1 - 1 & \\ \circ & \circ & \dots & \circ & \circ & \circ & \\ & & & \lambda_2^o & \dots & \lambda_2^o + m_2 - 1 & \\ & & & \circ & \dots & \circ & \end{array}$$



which illustrates some exponents and when  $\lambda_1^\circ + m_1 < \lambda_2^\circ + m_2$ ,

(14.46)

$$\begin{aligned} v_{2,\nu} &= u_{2,\nu} \quad (0 \leq \nu < m_2), \\ v_{1,\nu} &= u_{1,\nu} - \sum_{\max\{0, m_1 - \lambda_{2,1}^\circ\} \leq i < m_2} \frac{b_{\nu,i} u_{2,i}}{\lambda_1 - \lambda_2 + \lambda_{2,1}^\circ} \quad (0 \leq \nu < \min\{m_1, \lambda_{2,1}^\circ\}), \\ v_{1,\nu} &= \frac{u_{1,\nu} - u_{2,\nu - \lambda_{2,1}^\circ}}{\lambda_1 - \lambda_2 + \lambda_{2,1}^\circ} - \sum_{\max\{0, m_1 - \lambda_{2,1}^\circ\} \leq i < m_2} \frac{b_{\nu,i} u_{2,i}}{\lambda_1 - \lambda_2 + \lambda_{2,1}^\circ} \quad (\lambda_{2,1}^\circ \leq \nu < m_1) \end{aligned}$$

with

$$\begin{array}{ccccccc} \lambda_1^\circ & \lambda_1^\circ + 1 & \dots & \lambda_1^\circ + \lambda_{2,1}^\circ & \dots & \lambda_1^\circ + m_1 - 1 & \\ \circ & \text{---} & \circ & \text{---} & \circ & \text{---} & \circ \\ & & & \lambda_2^\circ & & \lambda_2^\circ - \lambda_{2,1}^\circ + m_1 - 1 & \lambda_2^\circ + m_2 - 1 \\ & & & \circ & & \text{---} & \circ \end{array}$$

and here  $b_{\nu,i} \in \mathbb{C}$ . Note that  $v_{j,\nu}$  ( $1 \leq j \leq N$ ,  $0 \leq \nu < m_j$ ) are linearly independent for any fixed  $\lambda$  in a neighborhood of  $\lambda^\circ$ .

*Proof.* See §3.1 and the proof of Lemma 6.5 (and [O3, Theorem 6.5] in a more general setting) for the construction of local solutions of  $Pu = 0$ .

Note that  $u_{j,\nu}$  for  $j \geq 3$  are holomorphic with respect to  $\lambda$  in a neighborhood of  $\lambda = \lambda^\circ$ . Moreover note that the local monodromy generator  $M_0$  of the solutions  $Pu = 0$  at  $x = 0$  satisfies  $\prod_{j=1}^N (M_0 - e^{2\pi\sqrt{-1}\lambda_j}) = 0$  and therefore the functions  $(\lambda_1 - \lambda_2 - \lambda_{2,1}^\circ)u_{j,\nu}$  of  $\lambda$  are holomorphically extended to the point  $\lambda = \lambda^\circ$  for  $j = 1$  and  $2$ , and the values of the functions at  $\lambda = \lambda^\circ$  are solutions of the equation  $Pu = 0$  with  $\lambda = \lambda^\circ$ .

Suppose  $\lambda_1^\circ + m_1 \geq \lambda_2^\circ + m_2$ . Then  $u_{j,\nu}$  ( $j = 1, 2$ ) are holomorphic with respect to  $\lambda$  at  $\lambda = \lambda^\circ$  and there exist  $b_{j,\nu} \in \mathbb{C}$  such that

$$u_{2,\nu}|_{\lambda=\lambda^\circ} = u_{1,\nu+\lambda_{2,1}^\circ}|_{\lambda=\lambda^\circ} + \sum_{m_2+\lambda_{2,1}^\circ \leq \nu < m_1} b_{\nu,i} (u_{1,i}|_{\lambda=\lambda^\circ})$$

and we have the proposition. Here

$$u_{2,\nu}|_{\lambda=\lambda^\circ} \equiv x^{\lambda_2^\circ} + \sum_{m_2+\lambda_{2,1}^\circ \leq \nu < m_1} b_{\nu,i} x^{\lambda_1^\circ + \nu} \pmod{x^{\lambda_1^\circ + m_1} \mathcal{O}_0}.$$

Next suppose  $\lambda_1^\circ + m_1 < \lambda_2^\circ + m_2$ . Then there exist  $b_{j,\nu} \in \mathbb{C}$  such that

$$\begin{aligned} ((\lambda_1 - \lambda_2 + \lambda_{2,1}^\circ)u_{1,\nu})|_{\lambda=\lambda^\circ} &= \sum_{\max\{0, m_1 - \lambda_{2,1}^\circ\} \leq i < m_2} b_{\nu,i} (u_{2,i}|_{\lambda=\lambda^\circ}) \\ &\quad (0 \leq \nu < \min\{m_1, \lambda_{2,1}^\circ\}), \\ u_{1,\nu}|_{\lambda=\lambda^\circ} &= \sum_{\max\{0, m_1 - \lambda_{2,1}^\circ\} \leq i < m_2} b_{\nu,i} (u_{2,i}|_{\lambda=\lambda^\circ}) \quad (\lambda_{2,1}^\circ \leq \nu < m_1) \end{aligned}$$

and we have the proposition.  $\square$

The proposition implies the following corollaries.

**Corollary 14.13.** *Retain the notation and the assumption in Proposition 14.12.*

i) *Let  $W_j(\lambda, x)$  be the Wronskian of  $u_{j,1}, \dots, u_{j,m_j}$  for  $j = 1, \dots, N$ . Then  $(\lambda_1 - \lambda_2 + \lambda_{2,1}^\circ)^{\ell_1} W_1(\lambda)$  and  $W_j(\lambda)$  with  $2 \leq j \leq N$  are holomorphic with respect to  $\lambda$  in a neighborhood of  $\lambda^\circ$  by putting*

$$(14.47) \quad \ell_1 = \max\{0, \min\{m_1, m_2, \lambda_{2,1}^\circ, \lambda_{2,1}^\circ + m_2 - m_1\}\}.$$

ii) Let

$$w_k = \sum_{j=1}^N \sum_{\nu=1}^{m_j} a_{j,\nu,k}(\lambda) u_{j,\nu,k}$$

be a local solution defined in a neighborhood of 0 with a holomorphic  $\lambda$  in a neighborhood of  $\lambda^o$ . Then

$$(\lambda_1 - \lambda_2 + \lambda_{2,1}^o)^{\ell_{2,j}} \det \left( a_{j,\nu,k}(\lambda) \right)_{\substack{1 \leq \nu \leq m_j \\ 1 \leq k \leq m_j}}$$

with

$$\begin{cases} \ell_{2,1} = \max\{0, \min\{m_1 - \lambda_{2,1}^o, m_2\}\}, \\ \ell_{2,2} = \min\{m_1, m_2\}, \\ \ell_{2,j} = 0 \quad (3 \leq j \leq N) \end{cases}$$

are holomorphic with respect to  $\lambda$  in a neighborhood of  $\lambda^o$ .

*Proof.* i) Proposition 14.12 shows that  $u_{j,\nu}$  ( $2 \leq j \leq N$ ,  $0 \leq \nu < m_j$ ) are holomorphic with respect to  $\lambda$  at  $\lambda^o$ . The functions  $u_{1,\nu}$  for  $\min\{m_1, \lambda_{2,1}^o\} \leq \nu \leq m_1$  are same. The functions  $u_{1,\nu}$  for  $0 \leq \nu < \min\{m_1, \lambda_{2,1}^o\}$  may have poles of order 1 along  $\lambda_2 - \lambda_1 = \lambda_{2,1}^o$  and their residues are linear combinations of  $u_{2,i}|_{\lambda_2=\lambda_1+\lambda_{2,1}^o}$  with  $\max\{0, m_1 - \lambda_{2,1}^o\} \leq i < m_2$ . Since

$$\begin{aligned} & \min\{\#\{\nu; 0 \leq \nu < \min\{m_1, \lambda_{2,1}^o\}\}, \#\{i; \max\{0, m_1 - \lambda_{2,1}^o\} \leq i < m_2\}\} \\ & = \max\{0, \min\{m_1, \lambda_{2,1}^o, m_2, m_2 - m_1 + \lambda_{2,1}^o\}\}, \end{aligned}$$

we have the claim.

ii) A linear combination of  $v_{j,\nu}$  ( $1 \leq j \leq N$ ,  $0 \leq \nu \leq m_j$ ) may have a pole of order 1 along  $\lambda_1 - \lambda_2 + \lambda_{2,1}^o$  and its residue is a linear combination of

$$\begin{aligned} & (u_{1,\nu} + \sum_{m_2+\lambda_{2,1}^o \leq i < m_1} b_{\nu+\lambda_{2,1}^o,i} u_{1,i})|_{\lambda_2=\lambda_1+\lambda_{2,1}^o} \quad (\lambda_{2,1}^o \leq \nu < \min\{m_1, m_2 + \lambda_{2,1}^o\}), \\ & (u_{2,\nu} + \sum_{\max\{0, m_1 - \lambda_{2,1}^o\} \leq i < m_2} b_{\nu+\lambda_{2,1}^o,i} u_{2,i})|_{\lambda_2=\lambda_1+\lambda_{2,1}^o} \quad (0 \leq \nu < m_1 - \lambda_{2,1}^o), \\ & \sum_{\max\{0, m_1 - \lambda_{2,1}^o\} \leq i < m_2} b_{\nu,i} u_{2,i}|_{\lambda_2=\lambda_1+\lambda_{2,1}^o} \quad (0 \leq \nu < \min\{m_1, \lambda_{2,1}^o\}). \end{aligned}$$

Since

$$\begin{aligned} & \#\{\nu; \lambda_{2,1}^o \leq \nu < \min\{m_1, m_2 + \lambda_{2,1}^o\}\} = \max\{0, \min\{m_1 - \lambda_{2,1}^o, m_2\}\}, \\ & \#\{\nu; 0 \leq \nu < m_1 - \lambda_{2,1}^o\} \\ & + \min\{\#\{i; \max\{0, m_1 - \lambda_{2,1}^o\} \leq i < m_2\}, \#\{\nu; 0 \leq \nu < \min\{m_1, \lambda_{2,1}^o\}\}\} \\ & = \min\{m_1, m_2\}, \end{aligned}$$

we have the claim.  $\square$

*Remark 14.14.* If the local monodromy of the solutions of  $Pu = 0$  at  $x = 0$  is locally non-degenerate, the value of  $(\lambda_1 - \lambda_2 + \lambda_{2,1}^o)^{\ell_1} W_1(\lambda)$  at  $\lambda = \lambda^o$  does not vanish.

**Corollary 14.15.** *Let  $Pu = 0$  be a differential equation of order  $n$  with a regular singularity at  $x = 0$  such that  $P$  contains a holomorphic parameter  $\lambda = (\lambda_1, \dots, \lambda_N)$  defined on  $\mathbb{C}^N$ . Suppose that the set of characteristic exponents of  $P$  at  $x = 0$  equals  $\{[\lambda_1]_{(m_1)}, \dots, [\lambda_N]_{(m_N)}\}$  with  $n = m_1 + \dots + m_N$ . Let  $u_{j,\nu}$  be the solutions of  $Pu = 0$  defined by (14.43).*

i) Let  $W_1(x, \lambda)$  denote the Wronskian of  $u_{1,1}, \dots, u_{1,m_1}$ . Then

$$(14.48) \quad \frac{W_1(x, \lambda)}{\prod_{j=2}^N \prod_{0 \leq \nu < \min\{m_1, m_j\}} \Gamma(\lambda_1 - \lambda_j + m_1 - \nu)}$$

is holomorphic for  $\lambda \in \mathbb{C}^N$ .

ii) Let

$$(14.49) \quad v_k(\lambda) = \sum_{j=1}^N \sum_{\nu=1}^{m_j} a_{j,\nu,k}(\lambda) u_{j,\nu} \quad (1 \leq k \leq m_1)$$

be local solutions of  $Pu = 0$  defined in a neighborhood of 0 which have a holomorphic parameter  $\lambda \in \mathbb{C}^N$ . Then

$$(14.50) \quad \frac{\det \left( a_{1,\nu,k}(\lambda) \right)_{\substack{1 \leq \nu \leq m_1 \\ 1 \leq k \leq m_1}}}{\prod_{j=2}^N \prod_{1 \leq \nu \leq \min\{m_1, m_j\}} \Gamma(\lambda_j - \lambda_1 - m_1 + \nu)}$$

is a holomorphic function of  $\lambda \in \mathbb{C}^N$ .

*Proof.* Let  $\lambda_{j,1}^o \in \mathbb{Z}$ . The order of poles of (14.48) and that of (14.50) along  $\lambda_j - \lambda_1 = \lambda_{j,1}^o$  are

$$\begin{aligned} & \#\{\nu; 0 \leq \nu < \min\{m_1, m_j\} \text{ and } m_1 - \lambda_{j,1}^o - \nu \leq 0\} \\ &= \#\{\nu; \max\{0, m_1 - \lambda_{j,1}^o\} \leq \nu < \min\{m_1, m_j\}\} \\ &= \max\{0, \min\{m_1, m_j, \lambda_{j,1}^o, \lambda_{j,1}^o + m_j - m_1\}\} \end{aligned}$$

and

$$\begin{aligned} & \#\{\nu; 1 \leq \nu \leq \min\{m_1, m_j\} \text{ and } \lambda_{j,1}^o - m_1 + \nu \leq 0\} \\ &= \max\{0, \min\{m_1, m_j, m_1 - \lambda_{j,1}^o\}\}, \end{aligned}$$

respectively. Hence Corollary 14.13 assures this corollary.  $\square$

*Remark 14.16.* The product of denominator of (14.48) and that of (14.50) equals the periodic function

$$\prod_{j=2}^N (-1)^{\lfloor \frac{\min\{m_1, m_j\}}{2} \rfloor + 1} \left( \frac{\pi}{\sin(\lambda_1 - \lambda_j)\pi} \right)^{\min\{m_1, m_j\}}.$$

**Definition 14.17** (generalized connection coefficient). Let  $P_{\mathbf{m}}u = 0$  be the Fuchsian differential equation with the Riemann scheme

$$(14.51) \quad \left\{ \begin{array}{cccccc} x = c_0 = 0 & c_1 = 1 & c_2 & \cdots & c_p = \infty \\ [\lambda_{0,1}]_{(m_{0,1})} & [\lambda_{1,1}]_{(m_{1,1})} & [\lambda_{2,1}]_{(m_{2,1})} & \cdots & [\lambda_{p,1}]_{(m_{p,1})} \\ \vdots & \vdots & \vdots & \vdots & \vdots \\ [\lambda_{0,n_0}]_{(m_{0,n_0})} & [\lambda_{1,n_1}]_{(m_{1,n_1})} & [\lambda_{2,n_2}]_{(m_{2,n_2})} & \cdots & [\lambda_{p,n_p}]_{(m_{p,n_p})} \end{array} \right\}.$$

We assume  $c_2, \dots, c_{p-1} \notin [0, 1]$ . Let  $u_{0,\nu}^{\lambda_{0,\nu}+k}$  ( $1 \leq \nu \leq n_0$ ,  $0 \leq k < m_{0,\nu}$ ) and  $u_{1,\nu}^{\lambda_{1,\nu}+k}$  ( $1 \leq \nu \leq n_1$ ,  $0 \leq k < m_{1,\nu}$ ) be local solutions of  $P_{\mathbf{m}}u = 0$  such that

$$(14.52) \quad \begin{cases} u_{0,\nu}^{\lambda_{0,\nu}+k} \equiv x^{\lambda_{0,\nu}+k} & \text{mod } x^{\lambda_{0,\nu}+m_{0,\nu}} \mathcal{O}_0, \\ u_{1,\nu}^{\lambda_{1,\nu}+k} \equiv (1-x)^{\lambda_{1,\nu}+k} & \text{mod } (1-x)^{\lambda_{1,\nu}+m_{1,\nu}} \mathcal{O}_1. \end{cases}$$

They are uniquely defined on  $(0, 1) \subset \mathbb{R}$  when  $\lambda_{j,\nu} - \lambda_{j,\nu'} \notin \mathbb{Z}$  for  $j = 0, 1$  and  $1 \leq \nu < \nu' \leq n_j$ . Then the connection coefficients  $c_{\nu,k}^{\nu',k'}(\lambda)$  are defined by

$$(14.53) \quad u_{0,\nu}^{\lambda_{0,\nu}+k} = \sum_{\nu',k'} c_{\nu,k}^{\nu',k'}(\lambda) u_{1,\nu'}^{\lambda_{1,\nu'}+k'}.$$

Note that  $c_{\nu,k}^{\nu',k'}(\lambda)$  is a meromorphic function of  $\lambda$  when  $\mathbf{m}$  is rigid.

Fix a positive integer  $n'$  and the integer sequences  $1 \leq \nu_1^0 < \nu_2^0 < \dots < \nu_L^0 \leq n_0$  and  $1 \leq \nu_1^1 < \nu_2^1 < \dots < \nu_{L'}^1 \leq n_1$  such that

$$(14.54) \quad n' = m_{0,\nu_1^0} + \dots + m_{0,\nu_L^0} = m_{1,\nu_1^1} + \dots + m_{1,\nu_{L'}^1}.$$

Then a *generalized connection coefficient* is defined by

$$(14.55) \quad \begin{aligned} c(0 : [\lambda_{0,\nu_1^0}]_{(m_{0,\nu_1^0})}, \dots, [\lambda_{0,\nu_L^0}]_{(m_{0,\nu_L^0})} \rightsquigarrow 1 : [\lambda_{1,\nu_1^1}]_{(m_{1,\nu_1^1})}, \dots, [\lambda_{1,\nu_{L'}^1}]_{(m_{1,\nu_{L'}^1})}) \\ := \det \left( c_{\nu,k}^{\nu',k'}(\lambda) \right)_{\substack{\nu \in \{\nu_1^0, \dots, \nu_L^0\}, 0 \leq k < m_{0,\nu} \\ \nu' \in \{\nu_1^1, \dots, \nu_{L'}^1\}, 0 \leq k' < m_{1,\nu'}}}. \end{aligned}$$

The connection coefficient defined in §14.1 corresponds to the case when  $n' = 1$ .

*Remark 14.18.* i) When  $m_{0,1} = m_{1,1}$ , Corollary 14.15 assures that

$$\frac{c(0 : [\lambda_{0,1}]_{(m_{0,1})} \rightsquigarrow 1 : [\lambda_{1,1}]_{(m_{1,1})})}{\prod_{\substack{2 \leq j \leq n_0 \\ 0 \leq k < \min\{m_{0,1}, m_{0,j}\}}} \Gamma(\lambda_{0,1} - \lambda_{0,j} + m_{0,1} - k) \cdot \prod_{\substack{2 \leq j \leq n_1 \\ 0 < k \leq \min\{m_{1,1}, m_{1,j}\}}} \Gamma(\lambda_{1,j} - \lambda_{1,1} - m_{1,1} + k)}$$

is holomorphic for  $\lambda_{j,\nu} \in \mathbb{C}$ .

ii) Let  $v_1, \dots, v_{n'}$  be generic solutions of  $P_{\mathbf{m}}u = 0$ . Then the generalized connection coefficient in Definition 14.17 corresponds to a usual connection coefficient of the Fuchsian differential equation satisfied by the Wronskian of the  $n'$  functions  $v_1, \dots, v_{n'}$ . The differential equation is of order  $\binom{n}{n'}$ . In particular, when  $n' = n - 1$ , the differential equation is isomorphic to the dual of the equation  $P_{\mathbf{m}} = 0$  (cf. Theorem 6.19) and therefore the result in §14.1 can be applied to the connection coefficient. The precise result will be explained in another paper.

*Remark 14.19.* The following procedure has not been completed in general. But we give a procedure to calculate the generalized connection coefficient (14.55), which we put  $c(\lambda)$  here for simplicity when  $\mathbf{m}$  is rigid.

(1) Let  $\bar{e} = (\bar{e}_{j,\nu})$  be the shift of the Riemann scheme  $\{\lambda_{\mathbf{m}}\}$  such that

$$(14.56) \quad \begin{cases} \bar{e}_{0,\nu} = -1 & (\nu \in \{1, 2, \dots, n_0\} \setminus \{\nu_1^0, \dots, \nu_L^0\}), \\ \bar{e}_{1,\nu} = 1 & (\nu \in \{1, 2, \dots, n_1\} \setminus \{\nu_1^1, \dots, \nu_{L'}^1\}), \\ \bar{e}_{j,\nu} = 0 & (\text{otherwise}). \end{cases}$$

Then for generic  $\lambda$  we show that the connection coefficient (14.55) converges to a non-zero meromorphic function  $\bar{c}(\lambda)$  of  $\lambda$  by the shift  $\{\lambda_{\mathbf{m}}\} \mapsto \{(\lambda + k\bar{e})_{\mathbf{m}}\}$  when  $\mathbb{Z}_{>0} \ni k \rightarrow \infty$ .

(2) Choose suitable linear functions  $b_i(\lambda)$  of  $\lambda$  by applying Proposition 14.12 or Corollary 14.15 to  $c(\lambda)$  so that  $e(\lambda) := \prod_{i=1}^N \Gamma(b_i(\lambda))^{-1} \cdot c(\lambda)\bar{c}(\lambda)^{-1}$  is holomorphic for any  $\lambda$ .

In particular, when  $L = L' = 1$  and  $\nu_1^0 = \nu_1^1 = 1$ , we may put

$$\begin{aligned} \{b_i\} = & \bigcup_{j=2}^{n_0} \{\lambda_{0,1} - \lambda_{0,j} + m_{0,1} - \nu; 0 \leq \nu < \min\{m_{0,1}, m_{0,j}\}\} \\ & \cup \bigcup_{j=2}^{n_1} \{\lambda_{1,j} - \lambda_{1,1} - m_{1,1} + \nu; 1 \leq \nu \leq \min\{m_{1,1}, m_{1,j}\}\}. \end{aligned}$$

- (3) Find the zeros of  $e(\lambda)$  some of which are explained by the reducibility or the shift operator of the equation  $P_{\mathbf{m}}u = 0$  and choose linear functions  $c_i(\lambda)$  of  $\lambda$  so that  $f(\lambda) := \prod_{i=1}^{N'} \Gamma(c_i(\lambda)) \cdot e(\lambda)$  is still holomorphic for any  $\lambda$ .  
(4) If  $N = N'$  and  $\sum_i d_i(\lambda) = \sum_i c_i(\lambda)$ , Lemma 14.20 assures  $f(\lambda) = \bar{c}(\lambda)$  and

$$(14.57) \quad c(\lambda) = \frac{\prod_{i=1}^N \Gamma(b_i(\lambda))}{\prod_{i=1}^N \Gamma(c_i(\lambda))} \cdot \bar{c}(\lambda)$$

because  $\frac{f(\lambda)}{f(\lambda+\epsilon)}$  is a rational function of  $\lambda$ , which follows from the existence of a shift operator assured by Theorem 13.2.

**Lemma 14.20.** *Let  $f(t)$  be a meromorphic function of  $t \in \mathbb{C}$  such that  $r(t) = \frac{f(t)}{f(t+1)}$  is a rational function and*

$$(14.58) \quad \lim_{\mathbb{Z}_{>0} \ni k \rightarrow \infty} f(t+k) = 1.$$

*Then there exists  $N \in \mathbb{Z}_{\geq 0}$  and  $b_i, c_i \in \mathbb{C}$  for  $i = 1, \dots, n$  such that*

$$(14.59) \quad b_1 + \dots + b_N = c_1 + \dots + c_N,$$

$$(14.60) \quad f(t) = \frac{\prod_{i=1}^N \Gamma(t + b_i)}{\prod_{i=1}^N \Gamma(t + c_i)}.$$

*Moreover, if  $f(t)$  is an entire function, then  $f(t)$  is the constant function 1.*

*Proof.* Since  $\lim_{k \rightarrow \infty} r(t+k) = 1$ , we may assume

$$r(t) = \frac{\prod_{i=1}^N (t + c_i)}{\prod_{i=1}^N (t + b_i)}$$

and then

$$f(t) = \frac{\prod_{i=1}^N \prod_{\nu=0}^{n-1} (t + c_i + \nu)}{\prod_{i=1}^N \prod_{\nu=0}^{n-1} (t + b_i + \nu)} f(t+n).$$

Since

$$\lim_{n \rightarrow \infty} \frac{n! n^{x-1}}{\prod_{\nu=0}^{n-1} (x + \nu)} = \Gamma(x),$$

the assumption implies (14.59) and (14.60).

We may assume  $b_i \neq c_j$  for  $1 \leq i \leq N$  and  $1 \leq j \leq N$ . Then the function (14.60) with (14.59) has a pole if  $N > 0$ .  $\square$

We have the following proposition for zeros of  $c(\lambda)$ .

**Proposition 14.21.** *Retain the notation in Remark 14.19 and fix  $\lambda$  so that*

$$(14.61) \quad \lambda_{j,\nu} - \lambda_{j,\nu'} \notin \mathbb{Z} \quad (j = 0, 1 \text{ and } 0 \leq \nu < \nu' \leq n_j).$$

- i) *The relation  $c(\lambda) = 0$  is valid if and only if there exists a non-zero function*

$$v = \sum_{\substack{\nu \in \{\nu_1^0, \dots, \nu_L^0\} \\ 0 \leq k < m_{0,\nu}}} C_{\nu,k} u_0^{\lambda_{0,\nu} + k} = \sum_{\nu \in \{1, \dots, n_1\} \setminus \{\nu_1^1, \dots, \nu_{L'}^1\}} C'_{\nu,k} u_1^{\lambda_{1,\nu} + k}$$

*on  $(0, 1)$  with  $C_{\nu,k}, C'_{\nu,k} \in \mathbb{C}$ .*

ii) Fix a shift  $\epsilon = (\epsilon_{j,\nu})$  compatible to  $\mathbf{m}$  and let  $R_{\mathbf{m}}(\epsilon, \lambda)$  be the shift operator in Theorem 13.2. Suppose  $R_{\mathbf{m}}(\epsilon, \lambda)$  is bijective, namely,  $c_{\mathbf{m}}(\epsilon; \lambda) \neq 0$  (cf. Theorem 13.7). Then  $c(\lambda + \epsilon) = 0$  if and only if  $c(\lambda) = 0$

*Proof.* Assumption (14.61) implies that  $\{u_0^{\lambda_0, \nu+k}\}$  and  $\{u_1^{\lambda_1, \nu+k}\}$  define sets of basis of local solutions of the equation  $P_{\mathbf{m}}u = 0$ . Hence the claim i) is clear from the definition of  $c(\lambda)$ .

Suppose  $c(\lambda) = 0$  and  $R_{\mathbf{m}}(\epsilon, \lambda)$  is bijective. Then applying the claim i) to  $R_{\mathbf{m}}(\epsilon, \lambda)v$ , we have  $c(\lambda + \epsilon) = 0$ . If  $R_{\mathbf{m}}(\epsilon, \lambda)$  is bijective, so is  $R_{\mathbf{m}}(-\epsilon, \lambda + \epsilon)$  and  $c(\lambda + \epsilon) = 0$  implies  $c(\lambda) = 0$ .  $\square$

**Corollary 14.22.** Let  $\mathbf{m} = \mathbf{m}' \oplus \mathbf{m}''$  be a rigid decomposition of  $\mathbf{m}$  such that

$$(14.62) \quad \sum_{\nu \in \{\nu_1^0, \dots, \nu_L^0\}} m'_{0,\nu} > \sum_{\nu \in \{\nu_1^1, \dots, \nu_{L'}^1\}} m'_{1,\nu}.$$

Then  $\Gamma(|\{\lambda_{\mathbf{m}'}\}|) \cdot c(\lambda)$  is holomorphic under the condition (14.61).

*Proof.* When  $|\{\lambda_{\mathbf{m}'}\}|=0$ , we have the decomposition  $P_{\mathbf{m}} = P_{\mathbf{m}''}P_{\mathbf{m}'}$  and hence  $c(\lambda) = 0$ . There exists a shift  $\epsilon$  compatible to  $\mathbf{m}$  such that  $\sum_{j=0}^p \sum_{\nu=1}^{n_j} m'_{j,\nu} \epsilon_{j,\nu} = 1$ . Let  $\lambda$  be generic under  $|\{\lambda_{\mathbf{m}}\}| = 0$  and  $|\{\lambda_{\mathbf{m}'}\}| \in \mathbb{Z} \setminus \{0\}$ . Then Theorem 13.8) ii) assures  $c_{\mathbf{m}}(\epsilon; \lambda) \neq 0$  and Proposition 14.21 proves the corollary.  $\square$

*Remark 14.23.* Suppose that Remark 14.19 (1) is established. Then Proposition 14.12 and Proposition 14.21 with Theorem 13.7 assure that the denominator and the numerator of the rational function which equals  $\frac{c(\lambda)}{c(\lambda+\bar{\epsilon})}$  are products of certain linear functions of  $\lambda$  and therefore (14.57) is valid with suitable linear functions  $b_i(\lambda)$  and  $c_i(\lambda)$  of  $\lambda$  satisfying  $\sum_{i=1}^N b_i(\lambda) = \sum_{i=1}^N c_i(\lambda)$ .

**Example 14.24** (generalized hypergeometric function). The generalized hypergeometric series (1.7) satisfies the equation  $P_n(\alpha; \beta)u = 0$  given by (15.19) and [Kh, §4.1.2 Example 9] shows that the equation is isomorphic to the Okubo system

$$(14.63) \quad \left( x - \begin{pmatrix} 1 & & & & & \\ & 0 & & & & \\ & & \ddots & & & \\ & & & \ddots & & \\ & & & & \ddots & \\ & & & & & 0 \end{pmatrix} \right) \frac{d\tilde{u}}{dx} = \begin{pmatrix} -\beta_n & 1 & & & & \\ \alpha_{2,1} & 0 & 1 & & & \\ \alpha_{3,1} & & 1 & 1 & & \\ \vdots & & & & \ddots & \\ \alpha_{n-1,1} & & & & & n-3 & & 1 \\ \alpha_{n,1} & -c_{n-1} & -c_{n-2} & \cdots & -c_2 & -c_1+(n-2) \end{pmatrix} \tilde{u}$$

with

$$u = \begin{pmatrix} u_1 \\ \vdots \\ u_n \end{pmatrix}, \quad u = u_1 \quad \text{and} \quad \sum_{\nu=1}^n \alpha_{\nu} = \sum_{\nu=1}^n \beta_{\nu}.$$

Let us calculate the connection coefficient

$$c(0:0 \rightsquigarrow 1:-\beta_n) = \lim_{x \rightarrow 1-0} (1-x)^{\beta_n} {}_nF_{n-1}(\alpha_1, \dots, \alpha_n; \beta_1, \dots, \beta_{n-1}; x) \quad (\operatorname{Re} \beta_n > 0).$$

Applying Theorem 14.10 to the system of Schlesinger canonical form satisfied by  $\operatorname{Ad}((1-x)^{\beta_n})$ , the connection coefficient satisfies Remark 14.19 i) with  $\bar{c}(\lambda) = 1$ , namely,

$$(14.64) \quad \lim_{k \rightarrow +\infty} c(0:0 \rightsquigarrow 1:-\beta_n)|_{\alpha_j \mapsto \alpha_j+k, \beta_j \mapsto \beta_j+k} \quad (1 \leq j \leq n) = 1.$$

Then Remark 14.19 ii) shows that  $\prod_{j=1}^n \Gamma(\beta_j)^{-1} \cdot c(0:0 \rightsquigarrow 1:-\beta_n)$  is a holomorphic function of  $(\alpha, \beta) \in \mathbb{C}^{n+(n-1)}$ .

Corresponding to the Riemann scheme (1.8), the existence of rigid decompositions

$$\overbrace{1 \cdots 1}^n; n-11; \overbrace{1 \cdots 1}^n = \overbrace{0 \cdots 0}^{n-1} 1; 10; 0 \cdots \overset{i}{1} \cdots 0 \oplus \overbrace{1 \cdots 1}^{n-1} 0; n-11; 1 \cdots \overset{i}{0} \cdots 1$$

for  $i = 1, \dots, n$  proves that  $\prod_{i=1}^n \Gamma(\alpha_i) \cdot \prod_{j=1}^n \Gamma(\beta_j)^{-1} \cdot c(0:0 \rightsquigarrow 1:-\beta_n)$  is also entire holomorphic. Then the procedure given in Remark 14.19 assures

$$(14.65) \quad c(0:0 \rightsquigarrow 1:-\beta_n) = \frac{\prod_{i=1}^n \Gamma(\beta_i)}{\prod_{i=1}^n \Gamma(\alpha_i)}.$$

We can also prove (14.65) as in the following way. Since

$$\frac{d}{dx} F(\alpha; \beta; x) = \frac{\alpha_1 \cdots \alpha_n}{\beta_1 \cdots \beta_{n-1}} F(\alpha_1 + 1, \dots, \alpha_n + 1; \beta_1 + 1, \dots, \beta_{n-1} + 1; x)$$

and

$$\frac{d}{dx} (1-x)^{-\beta_n} (1 + (1-x)\mathcal{O}_1) = \beta_n (1-x)^{-\beta_n-1} (1 + (1-x)\mathcal{O}_1),$$

we have

$$\frac{c(0:0 \rightsquigarrow 1:-\beta_n)}{c(0:0 \rightsquigarrow 1:-\beta_n)|_{\alpha_j \mapsto \alpha_j+1, \beta_j \mapsto \beta_j+1}} = \frac{\alpha_1 \cdots \alpha_n}{\beta_1 \cdots \beta_n},$$

which proves (14.65) because of (14.64).

A further study of generalized connection coefficients will be developed in another paper. In this paper we will only give some examples in §15.5 and §15.7.5.

## 15. EXAMPLES

When we classify tuples of partitions in this section, we identify the tuples which are isomorphic to each other. For example, 21, 111, 111 is isomorphic to any one of 12, 111, 111 and 111, 21, 111 and 21, 3, 111, 111.

Most of our results in this note are constructible and can be implemented in computer programs. Several reductions and constructions and decompositions of tuples of partitions and connections coefficients associated with Riemann schemes etc. can be computed by a program `okubo` written by the author (cf. §15.11).

In §15.1 and §15.2 we list fundamental and rigid tuples respectively, most of which are obtained by the program `okubo`.

In §15.3 and §15.4 we apply our fractional calculus to Jordan-Pochhammer equations and a hypergeometric family (generalized hypergeometric equations), respectively. Most of the results in these sections are known but it will be useful to understand our unifying interpretation and apply it to general Fuchsian equations.

In §15.5 we study an even family and an odd family corresponding to Simpson's list [Si]. The differential equations of an even family appear in suitable restrictions of Heckman-Opdam hypergeometric systems and in particular the explicit calculation of a connection coefficient for an even family was author's original motivation for the current study of Fuchsian differential equations (cf. [OS]).

In §15.7, §15.8 and §15.9 we study the rigid Fuchsian differential equations of order not larger than 4 and those of order 5 or 6 and the equations belonging to 12 maximal series classified by [Ro] which contain Yokoyama's list [Yo].

In §15.6 we give some interesting identities of trigonometric functions as a consequence of the explicit value of connection coefficients.

We examine Appell hypergeometric equations in §15.10, which will be further discussed in another paper.

In §15.11 we explain computer programs which calculate the results described in this paper.

15.1. **Basic tuples.** The number of basic tuples and fundamental tuples (cf. Definition 8.14) with a given  $\text{Pid}x$  are as follows.

$\text{Pid}x$	0	1	2	3	4	5	6	7	8	9	10	11
# fund. tuples	1	4	13	36	67	103	162	243	305	456	578	720
# basic tuples	0	4	13	36	67	90	162	243	305	420	565	720
# basic triplets	0	3	9	24	44	56	97	144	163	223	291	342
# basic 4-tuples	0	1	3	9	17	24	45	68	95	128	169	239
maximal order	6	12	18	24	30	36	42	48	54	60	66	72

Note that if  $\mathbf{m}$  is a basic tuple with  $\text{idx } \mathbf{m} < 0$ , then

$$(15.1) \quad \text{Pid}x \, k\mathbf{m} = 1 + k^2(\text{Pid}x \, \mathbf{m} - 1) \quad (k = 1, 2, \dots).$$

Hence the non-trivial fundamental tuple  $\mathbf{m}$  with  $\text{Pid}x \, \mathbf{m} \leq 4$  or equivalently  $\text{idx } \mathbf{m} \geq -6$  is always basic.

The tuple  $2\mathbf{m}$  with a basic tuple  $\mathbf{m}$  satisfying  $\text{Pid}x \, \mathbf{m} = 2$  is a fundamental tuple and  $\text{Pid}x \, 2\mathbf{m} = 5$ . The tuple  $422, 44, 44, 44$  is this example.

15.1.1.  $\text{Pid}x \, \mathbf{m} = 1$ . There exist 4 basic tuples: (cf. [Ko3], Corollary 8.3)

$$\tilde{D}_4: 11,11,11,11 \quad \tilde{E}_6: 111,111,111 \quad \tilde{E}_7: 22,1111,1111 \quad \tilde{E}_8: 33,222,111111$$

They are not of Okubo type. The tuples of partitions of Okubo type with minimal order which are reduced to the above basic tuples are as follows.

$$\tilde{D}_4: 21,21,21,111 \quad \tilde{E}_6: 211,211,1111 \quad \tilde{E}_7: 32,2111,11111 \quad \tilde{E}_8: 43,322,111111$$

The list of simply reducible tuples of partitions whose indices of rigidity equal 0 is given in Example 8.17.

We list the number of realizable tuples of partitions whose indices of rigidity equal 0 according to their orders and the corresponding fundamental tuple.

ord	11,11,11,11	111,111,111	22,1111,1111	33,222,111111	total
2	1				1
3	1	1			2
4	4	1	1		6
5	6	3	1		10
6	21	8	5	1	35
7	28	15	6	1	50
8	74	31	21	4	130
9	107	65	26	5	203
10	223	113	69	12	417
11	315	204	90	14	623
12	616	361	205	37	1219
13	808	588	256	36	1688
14	1432	948	517	80	2977
15	1951	1508	659	100	4218
16	3148	2324	1214	179	6865
17	4064	3482	1531	194	9271
18	6425	5205	2641	389	14660
19	8067	7503	3246	395	19211
20	12233	10794	5400	715	29142

15.1.2.  $\text{Pid}x \, \mathbf{m} = 2$ . There are 13 basic tuples (cf. Proposition 8.10, [O6, Proposition 8.4]):

$$\begin{array}{lll} +2: 11, 11, 11, 11, 11 & 3: 111, 111, 21, 21 & *4: 211, 22, 22, 22 \\ 4: 1111, 22, 22, 31 & 4: 1111, 1111, 211 & 5: 11111, 11111, 32 \\ 5: 11111, 221, 221 & 6: 111111, 2211, 33 & *6: 2211, 222, 222 \end{array}$$



\*8: 22211, 2222, 44      8: 11111111, 332, 44      10: 22222, 3331, 55  
 \*12: 2222211, 444, 66

Here the number preceding to a tuple is the order of the tuple and the sign \* means that the tuple is the one given in Example 9.50 ( $D_4^{(m)}$ ,  $E_6^{(m)}$ ,  $E_7^{(m)}$  and  $E_8^{(m)}$ ) and the sign + means  $d(\mathbf{m}) < 0$ .

15.1.3.  $\text{Pid}x \mathbf{m} = 3$ . There are 36 basic tuples

+2: 11, 11, 11, 11, 11, 11	3: 111, 21, 21, 21, 21	4: 22, 22, 22, 31, 31
+3: 111, 111, 111, 21	+4: 1111, 22, 22, 22	4: 1111, 1111, 31, 31
4: 211, 211, 22, 22	4: 1111, 211, 22, 31	*6: 321, 33, 33, 33
6: 222, 222, 33, 51	+4: 1111, 1111, 1111	5: 11111, 11111, 311
5: 11111, 2111, 221	6: 11111, 222, 321	6: 111111, 21111, 33
6: 21111, 222, 222	6: 111111, 111111, 42	6: 222, 33, 33, 42
6: 111111, 33, 33, 51	6: 2211, 2211, 222	7: 1111111, 2221, 43
7: 1111111, 331, 331	7: 2221, 2221, 331	8: 11111111, 3311, 44
8: 222111, 2222, 44	8: 22211, 22211, 44	*9: 3321, 333, 333
9: 111111111, 333, 54	9: 22221, 333, 441	10: 1111111111, 442, 55
10: 22222, 3322, 55	10: 222211, 3331, 55	12: 22221111, 444, 66
*12: 33321, 3333, 66	14: 2222222, 554, 77	*18: 3333321, 666, 99

15.1.4.  $\text{Pid}x \mathbf{m} = 4$ . There are 67 basic tuples

+2: 11, 11, 11, 11, 11, 11, 11	3: 21, 21, 21, 21, 21, 21	+3: 111, 111, 21, 21, 21
+4: 22, 22, 22, 22, 31	4: 211, 22, 22, 31, 31	4: 1111, 22, 31, 31, 31
+3: 111, 111, 111, 111	+4: 1111, 1111, 22, 31	4: 1111, 211, 22, 22
4: 211, 211, 211, 22	4: 1111, 211, 211, 31	5: 11111, 11111, 41, 41
5: 11111, 221, 32, 41	5: 221, 221, 221, 41	5: 11111, 32, 32, 32
5: 221, 221, 32, 32	6: 3111, 33, 33, 33	6: 2211, 2211, 2211
+6: 222, 33, 33, 33	6: 222, 33, 33, 411	6: 2211, 222, 33, 51
*8: 431, 44, 44, 44	8: 11111111, 44, 44, 71	5: 11111, 11111, 221
5: 11111, 2111, 2111	+6: 111111, 111111, 33	+6: 111111, 222, 222
6: 111111, 111111, 411	6: 111111, 222, 3111	6: 21111, 2211, 222
6: 111111, 2211, 321	6: 2211, 33, 33, 42	7: 1111111, 1111111, 52
7: 1111111, 322, 331	7: 2221, 2221, 322	7: 11111111, 22111, 43
7: 22111, 2221, 331	8: 11111111, 3221, 44	8: 111111111, 2222, 53
8: 2222, 2222, 431	8: 2111111, 2222, 44	8: 221111, 22211, 44
9: 33111, 333, 333	9: 3222, 333, 333	9: 22221, 22221, 54
9: 222111, 333, 441	9: 111111111, 441, 441	10: 22222, 33211, 55
10: 1111111111, 433, 55	10: 1111111111, 4411, 55	10: 2221111, 3331, 55
10: 222211, 3322, 55	12: 222111111, 444, 66	12: 333111, 3333, 66
12: 33222, 3333, 66	12: 222222, 4431, 66	*12: 4431, 444, 444
12: 111111111111, 552, 66	12: 3333, 444, 552	14: 33332, 4442, 77
14: 2222211, 554, 77	15: 33333, 555, 771	*16: 44431, 4444, 88
16: 333331, 5551, 88	18: 33333111, 666, 99	18: 3333222, 666, 99
*24: 4444431, 888, cc		

Here a, b, c, ... represent 10, 11, 12, ..., respectively.

15.1.5. *Dynkin diagrams of basic tuples whose indices of rigidity equals  $-2$ .* We express the basic root  $\alpha_{\mathbf{m}}$  for  $\text{Pid}x \mathbf{m} = 2$  using the Dynkin diagram (See (9.11) for  $\text{Pid}x \mathbf{m} = 1$ ). The circles in the diagram represent the simple roots in  $\text{supp } \alpha_{\mathbf{m}}$  and two circles are connected by a line if the inner product of the corresponding simple roots is not zero. The number attached to a circle is the corresponding coefficient  $n$  or  $n_{j,\nu}$  in the expression (9.12).

For example, if  $\mathbf{m} = 22, 22, 22, 211$ , then  $\alpha_{\mathbf{m}} = 4\alpha_0 + 2\alpha_{0,1} + 2\alpha_{1,1} + 2\alpha_{2,1} + 2\alpha_{3,1} + \alpha_{3,2}$ , which corresponds to the second diagram in the following.

The circle with a dot at the center means a simple root whose inner product with  $\alpha_{\mathbf{m}}$  does not vanish. Moreover the type of the root system  $\Pi(\mathbf{m})$  (cf. (9.46)) corresponding to the simple roots without a dot is given.

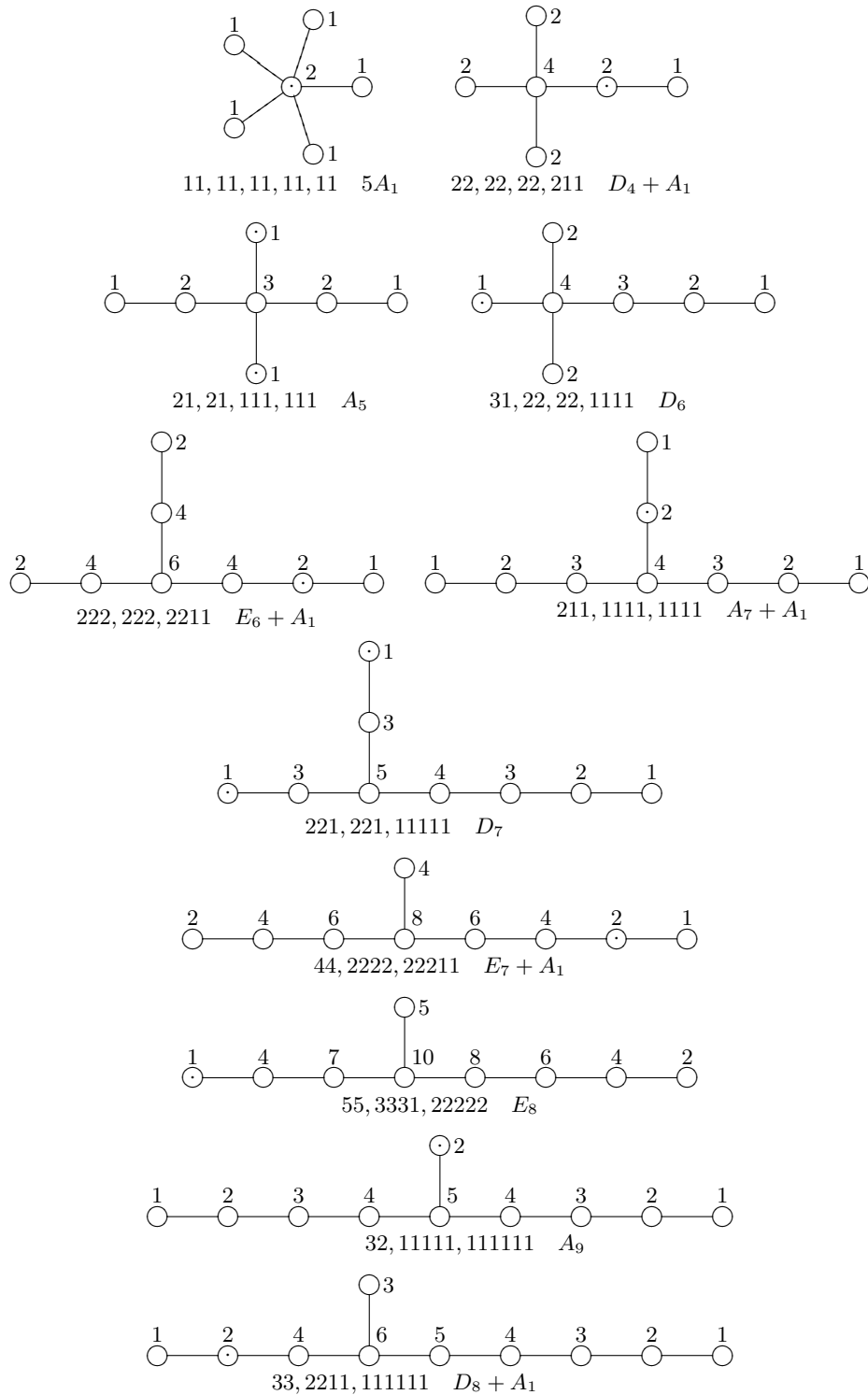

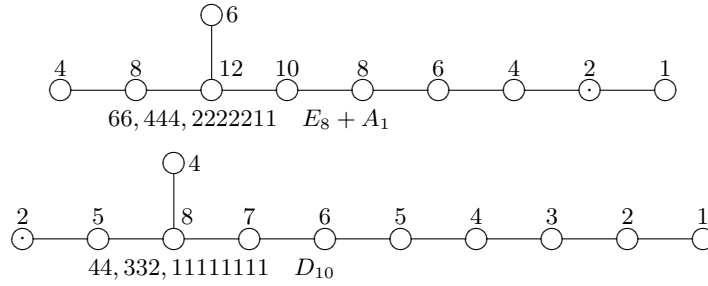

15.2. Rigid tuples.

15.2.1. *Simpson's list.* Simpson [Si] classified the rigid tuples containing the partition  $11 \cdots 1$  into 4 types (Simpson's list), which follows from Proposition 8.16. They are  $H_n, EO_{2m}, EO_{2m+1}$  and  $X_6$  in the following table.

See Remark 9.11 ii) for  $[\Delta(\mathbf{m})]$  with these rigid tuples  $\mathbf{m}$ .

The simply reducible rigid tuple (cf. §8.5) which is not in Simpson's list is isomorphic to 21111, 222, 33.

order	type	name	partitions
$n$	$H_n$	hypergeometric family	$1^n, 1^n, n - 11$
$2m$	$EO_{2m}$	even family	$1^{2m}, mm - 11, mm$
$2m + 1$	$EO_{2m+1}$	odd family	$1^{2m+1}, mm1, m + 1m$
6	$X_6 = \gamma_{6,2}$	extra case	111111, 222, 42
6	$\gamma_{6,6}$		21111, 222, 33
$n$	$P_n$	Jordan Pochhammer	$n - 11, n - 11, \dots \in \mathcal{P}_{n+1}^{(n)}$

$$H_1 = EO_1, H_2 = EO_2 = P_2, H_3 = EO_3.$$

15.2.2. *Isomorphic classes of rigid tuples.* Let  $\mathcal{R}_{p+1}^{(n)}$  be the set of rigid tuples in  $\mathcal{P}_{p+1}^{(n)}$ . Put  $\mathcal{R}_{p+1} = \bigcup_{n=1}^{\infty} \mathcal{R}_{p+1}^{(n)}$ ,  $\mathcal{R}^{(n)} = \bigcup_{p=2}^{\infty} \mathcal{R}_{p+1}^{(n)}$  and  $\mathcal{R} = \bigcup_{n=1}^{\infty} \mathcal{R}^{(n)}$ . The sets of isomorphic classes of the elements of  $\mathcal{R}_{p+1}^{(n)}$  (resp.  $\mathcal{R}_{p+1}, \mathcal{R}^{(n)}$  and  $\mathcal{R}$ ) are denoted  $\bar{\mathcal{R}}_{p+1}^{(n)}$  (resp.  $\bar{\mathcal{R}}_{p+1}, \bar{\mathcal{R}}^{(n)}$  and  $\bar{\mathcal{R}}$ ). Then the number of the elements of  $\bar{\mathcal{R}}^{(n)}$  are as follows.

$n$	$\#\bar{\mathcal{R}}_3^{(n)}$	$\#\bar{\mathcal{R}}^{(n)}$	$n$	$\#\bar{\mathcal{R}}_3^{(n)}$	$\#\bar{\mathcal{R}}^{(n)}$	$n$	$\#\bar{\mathcal{R}}_3^{(n)}$	$\#\bar{\mathcal{R}}^{(n)}$
2	1	1	15	1481	2841	28	114600	190465
3	1	2	16	2388	4644	29	143075	230110
4	3	6	17	3276	6128	30	190766	310804
5	5	11	18	5186	9790	31	235543	371773
6	13	28	19	6954	12595	32	309156	493620
7	20	44	20	10517	19269	33	378063	588359
8	45	96	21	14040	24748	34	487081	763126
9	74	157	22	20210	36078	35	591733	903597
10	142	306	23	26432	45391	36	756752	1170966
11	212	441	24	37815	65814	37	907150	1365027
12	421	857	25	48103	80690	38	1143180	1734857
13	588	1177	26	66409	112636	39	1365511	2031018
14	1004	2032	27	84644	139350	40	1704287	2554015

15.2.3. *Rigid tuples of order at most 8.* We show all the rigid tuples whose orders are not larger than 8.

$$2: 11, 11, 11 \quad (H_2: \text{Gauss})$$

3:111,111,21 ( $H_3 : {}_3F_2$ )	3:21,21,21,21 ( $P_3$ )
4:1111,1111,31 ( $H_4 : {}_4F_3$ )	4:1111,211,22 ( $EO_4$ : even)
4:211,211,211 ( $B_4, \Pi_2, \alpha_4$ )	4:211,22,31,31 ( $I_4, \Pi_2^*$ )
4: <u>22,22,22,31</u> ( $P_{4,4}$ )	4:31,31,31,31,31 ( $P_4$ )
5:11111,11111,41 ( $H_5 : {}_5F_4$ )	5:11111,221,32 ( $EO_5$ : odd)
5:2111,2111,32 ( $C_5$ )	5:2111,221,311 ( $B_5, \text{III}_2$ )
5: <u>221,221,221</u> ( $\alpha_5$ )	5:221,221,41,41 ( $J_5$ )
5:221,32,32,41	5:311,311,32,41 ( $I_5, \text{III}_2^*$ )
5: <u>32,32,32,32</u> ( $P_{4,5}$ )	5: <u>32,32,41,41,41</u> ( $M_5$ )
5:41,41,41,41,41 ( $P_5$ )	
6:111111,111111,51 ( $H_6 : {}_6F_5$ )	6:111111,222,42 ( $D_6 = X_6$ : extra)
6:111111,321,33 ( $EO_6$ : even)	6:21111,2211,42 ( $E_6$ )
6: <u>21111,222,33</u> ( $\gamma_{6,6}$ )	6:21111,222,411 ( $F_6, \text{IV}$ )
6: <u>21111,3111,33</u> ( $C_6$ )	6: <u>2211,2211,33</u> ( $\beta_6$ )
6:2211,2211,411 ( $G_6$ )	6: <u>2211,321,321</u>
6: <u>222,222,321</u> ( $\alpha_6$ )	6:222,3111,321
6:3111,3111,321 ( $B_6, \Pi_3$ )	6:2211,222,51,51 ( $J_6$ )
6:2211,33,42,51	6: <u>222,33,33,51</u>
6:222,33,411,51	6:3111,33,411,51 ( $I_6, \Pi_3^*$ )
6:321,321,42,51	6:321,42,42,42
6: <u>33,33,33,42</u> ( $P_{4,6}$ )	6: <u>33,33,411,42</u>
6:33,411,411,42	6:411,411,411,42 ( $N_6, \text{IV}^*$ )
6:33,42,42,51,51 ( $M_6$ )	6:321,33,51,51,51 ( $K_6$ )
6:411,42,42,51,51	6:51,51,51,51,51,51,51 ( $P_6$ )
7:1111111,1111111,61 ( $H_7$ )	7:1111111,331,43 ( $EO_7$ )
7:211111,2221,52 ( $D_7$ )	7:211111,322,43 ( $\gamma_7$ )
7:22111,22111,52 ( $E_7$ )	7:22111,2221,511 ( $F_7$ )
7:22111,3211,43	7:22111,331,421
7: <u>2221,2221,43</u> ( $\beta_7$ )	7:2221,31111,43
7: <u>2221,322,421</u>	7: <u>2221,331,331</u>
7:2221,331,4111	7:31111,31111,43 ( $C_7$ )
7:31111,322,421	7:31111,331,4111 ( $B_7, \text{III}_3$ )
7:3211,3211,421	7: <u>3211,322,331</u>
7:3211,322,4111	7: <u>322,322,322</u> ( $\alpha_7$ )
7:2221,2221,61,61 ( $J_7$ )	7:2221,43,43,61
7:3211,331,52,61	7:322,322,52,61
7:322,331,511,61	7:322,421,43,61
7:322,43,52,52	7: <u>331,331,43,61</u>
7:331,43,511,52	7:4111,4111,43,61 ( $I_7, \text{III}_3^*$ )
7:4111,43,511,52	7:421,421,421,61
7:421,421,52,52	7:421,43,43,52
7: <u>43,43,43,43</u> ( $P_{4,7}$ )	7:421,43,511,511
7:331,331,61,61,61 ( $L_7$ )	7:421,43,52,61,61
7:43,43,43,61,61	7:43,52,52,52,61
7:511,511,52,52,61 ( $N_7$ )	7:43,43,61,61,61,61 ( $K_7$ )
7:52,52,52,61,61,61 ( $M_7$ )	7:61,61,61,61,61,61,61,61 ( $P_7$ )
8:11111111,11111111,71 ( $H_8$ )	8:11111111,431,44 ( $EO_8$ )

8:2111111,2222,62 ( $D_8$ )	8:2111111,332,53
8:2111111,422,44	8:221111,22211,62 ( $E_8$ )
8:221111,2222,611 ( $F_8$ )	8:221111,3311,53
8: <u>221111,332,44</u> ( $\gamma_8$ )	8:221111,4211,44
8:22211,22211,611 ( $G_8$ )	8:22211,3221,53
8: <u>22211,3311,44</u>	8:22211,332,521
8:22211,41111,44	8:22211,431,431
8:22211,44,53,71	8: <u>2222,2222,53</u> ( $\beta_{8,2}$ )
8:2222,32111,53	8: <u>2222,3221,44</u> ( $\beta_{8,4}$ )
8:2222,3311,521	8:2222,332,5111
8:2222,422,431	8:311111,3221,53
8:311111,332,521	8:311111,41111,44 ( $C_8$ )
8:32111,32111,53	8: <u>32111,3221,44</u>
8:32111,3311,521	8: <u>32111,332,5111</u>
8:32111,422,431	8:3221,3221,521
8:3221,3311,5111	8:3221,332,431
8: <u>332,332,332</u> ( $\alpha_8$ )	8: <u>332,332,4211</u>
8: <u>332,41111,422</u>	8:332,4211,4211
8:3221,4211,431	8: <u>3311,3311,431</u>
8: <u>3311,332,422</u>	8: <u>3221,422,422</u>
8:3311,4211,422	8:41111,41111,431 ( $B_8, II_4$ )
8:41111,4211,422	8:4211,4211,4211
8:22211,2222,71,71 ( $J_8$ )	8: <u>2222,44,44,71</u>
8:3221,332,62,71	8: <u>3221,44,521,71</u>
8:3221,44,62,62	8:3311,3311,62,71
8:3311,332,611,71	8:3311,431,53,71
8:3311,44,611,62	8:332,422,53,71
8: <u>332,431,44,71</u>	8:332,44,611,611
8:332,53,53,62	8:41111,44,5111,71 ( $I_8, II_4^*$ )
8:41111,44,611,62	8:4211,422,53,71
8:4211,44,611,611	8:4211,53,53,62
8: <u>422,422,44,71</u>	8:422,431,521,71
8: <u>422,431,62,62</u>	8: <u>422,44,53,62</u>
8:431,44,44,62	8: <u>431,44,53,611</u>
8:422,53,53,611	8:431,431,611,62
8:431,521,53,62	8: <u>44,44,44,53</u> ( $P_{4,8}$ )
8:44,5111,521,62	8:44,521,521,611
8:44,521,53,53	8:5111,5111,53,62
8:5111,521,53,611	8:521,521,521,62
8:332,332,71,71,71	8:332,44,62,71,71
8:4211,44,62,71,71	8:422,44,611,71,71
8:431,53,53,71,71	8:44,44,62,62,71
8:44,53,611,62,71	8:521,521,53,71,71
8:521,53,62,62,71	8:53,53,611,611,71
8:53,62,62,62,62	8:611,611,611,62,62 ( $N_8$ )
8:53,53,62,71,71,71	8:431,44,71,71,71,71 ( $K_8$ )
8:611,62,62,62,71,71 ( $M_8$ )	8:71,71,71,71,71,71,71,71 ( $P_8$ )

Here the underlined tuples are not of Okubo type (cf. (13.30)).

The tuples  $H_n$ ,  $EO_n$  and  $X_6$  are tuples in Simpson's list. The series  $A_n = EO_n$ ,  $B_n$ ,  $C_n$ ,  $D_n$ ,  $E_n$ ,  $F_n$ ,  $G_{2m}$ ,  $I_n$ ,  $J_n$ ,  $K_n$ ,  $L_{2m+1}$ ,  $M_n$  and  $N_n$  are given in [Ro] and called submaximal series. The Jordan-Pochhammer tuples are denoted by  $P_n$  and the series  $H_n$  and  $P_n$  are called maximal series by [Ro]. The series  $\alpha_n, \beta_n, \gamma_n$  and

$\delta_n$  are given in [Ro] and called minimal series. See §15.9 for these series introduced by [Ro]. Then  $\delta_n = P_{4,n}$  and they are generalized Jordan-Pochhammer tuples (cf. Example 12.5 and §15.9.13). Moreover  $\Pi_n, \Pi_n^*, \text{III}_n, \text{III}_n^*, \text{IV}$  and  $\text{IV}^*$  are in Yokoyama's list in [Yo] (cf. §15.9.15).

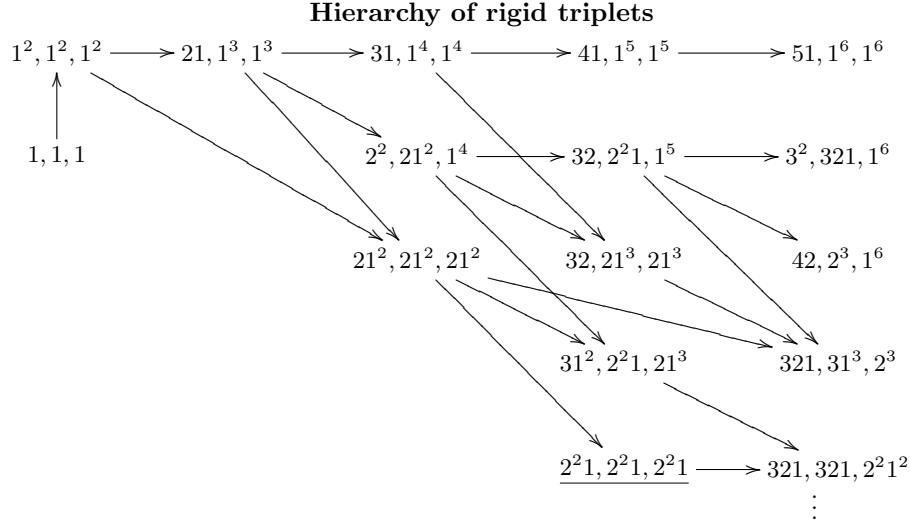

Here the arrows represent certain operations  $\partial_\ell$  of tuples given by Definition 7.6.

### 15.3. Jordan-Pochhammer family. $P_n$

We have studied the the Riemann scheme of this family in Example 2.8 iii).

$$\mathbf{m} = (p-11, p-11, \dots, p-11) \in \mathcal{P}_{p+1}^{(p)}$$

$$\left\{ \begin{array}{cccccc} x=0 & 1 = \frac{1}{c_1} & \cdots & \frac{1}{c_{p-1}} & \infty & \\ [0]_{(p-1)} & [0]_{(p-1)} & \cdots & [0]_{(p-1)} & [1-\mu]_{(p-1)} & \\ \lambda_0 + \mu & \lambda_1 + \mu & \cdots & \lambda_{p-1} + \mu & -\lambda_0 - \cdots - \lambda_{p-1} - \mu & \end{array} \right\}$$

$$[\Delta(\mathbf{m})] = 1^{p+1} \cdot (p-1)$$

$$P_p = H_1 \oplus P_{p-1} : p+1 = (p-1)H_1 \oplus H_1 : 1$$

Here the number of the decompositions of a given type is shown after the decompositions. For example,  $P_p = H_1 \oplus P_{p-1} : p+1 = (p-1)H_1 \oplus H_1 : 1$  represents the decompositions

$$\begin{aligned} \mathbf{m} &= 10, \dots, \overset{\nu}{01}, \dots, 10 \oplus p-21, \dots, p-10, \dots, p-21 \quad (\nu = 0, \dots, p) \\ &= (p-1)(10, \dots, 10) \oplus 01, \dots, 01. \end{aligned}$$

The differential equation  $P_{P_p}(\lambda, \mu)u = 0$  with this Riemann scheme is given by

$$P_{P_p}(\lambda, \mu) := \text{RAd}(\partial^{-\mu}) \circ \text{RAd}\left(x^{\lambda_0} \prod_{j=1}^{p-1} (1 - c_j x)^{\lambda_j}\right) \partial$$

and then

$$(15.2) \quad \begin{aligned} P_{P_p}(\lambda, \mu) &= \sum_{k=0}^p p_k(x) \partial^{p-k}, \\ p_k(x) &:= \binom{-\mu + p - 1}{k} p_0^{(k)}(x) + \binom{-\mu + p - 1}{k-1} q^{(k-1)}(x) \end{aligned}$$

with

$$(15.3) \quad p_0(x) = x \prod_{j=1}^{p-1} (1 - c_j x), \quad q(x) = p_0(x) \left( -\frac{\lambda_0}{x} + \sum_{j=1}^{p-1} \frac{c_j \lambda_j}{1 - c_j x} \right).$$

It follows from Theorem 12.10 that the equation is irreducible if and only if

$$(15.4) \quad \lambda_j \notin \mathbb{Z} \quad (j = 0, \dots, p-1), \quad \mu \notin \mathbb{Z} \quad \text{and} \quad \lambda_0 + \dots + \lambda_{p-1} + \mu \notin \mathbb{Z}.$$

The normalized solution at 0 corresponding to the exponent  $\lambda_0 + \mu$  is

$$\begin{aligned} u_0^{\lambda_0 + \mu}(x) &= \frac{\Gamma(\lambda_0 + \mu + 1)}{\Gamma(\lambda_0 + 1)\Gamma(\mu)} \int_0^x \left( t^{\lambda_0} \prod_{j=1}^{p-1} (1 - c_j t)^{\lambda_j} \right) (x-t)^{\mu-1} dt \\ &= \frac{\Gamma(\lambda_0 + \mu + 1)}{\Gamma(\lambda_0 + 1)\Gamma(\mu)} \int_0^x \sum_{m_1=0}^{\infty} \dots \sum_{m_{p-1}=0}^{\infty} \frac{(-\lambda_1)_{m_1} \dots (-\lambda_{p-1})_{m_{p-1}}}{m_1! \dots m_{p-1}!} \\ &\quad c_2^{m_2} \dots c_{p-1}^{m_{p-1}} t^{\lambda_0 + m_1 + \dots + m_{p-1}} (x-t)^{\mu-1} dt \\ &= \sum_{m_1=0}^{\infty} \dots \sum_{m_{p-1}=0}^{\infty} \frac{(\lambda_0 + 1)_{m_1 + \dots + m_{p-1}} (-\lambda_1)_{m_1} \dots (-\lambda_{p-1})_{m_{p-1}}}{(\lambda_0 + \mu + 1)_{m_1 + \dots + m_{p-1}} m_1! \dots m_{p-1}!} \\ &\quad c_2^{m_2} \dots c_{p-1}^{m_{p-1}} x^{\lambda_0 + \mu + m_1 + \dots + m_{p-1}} \\ &= x^{\lambda_0 + \mu} \left( 1 - \frac{(\lambda_0 + 1)(\lambda_1 c_1 + \dots + \lambda_{p-1} c_{p-1})}{\lambda_0 + \mu + 1} x + \dots \right). \end{aligned}$$

This series expansion of the solution is easily obtained from the formula in §4 (cf. Theorem 10.1) and Theorem 13.3 gives the recurrence relation

$$(15.5) \quad u_0^{\lambda_0 + \mu}(x) = u_0^{\lambda_0 + \mu}(x) \Big|_{\lambda_1 \rightarrow \lambda_1 - 1} - \left( \frac{\lambda_0}{\lambda_0 + \mu} u_0^{\lambda_0 + \mu}(x) \right) \Big|_{\substack{\lambda_0 \rightarrow \lambda_0 + 1 \\ \lambda_1 \rightarrow \lambda_1 - 1}}.$$

Lemma 14.2 with  $a = \lambda_0$ ,  $b = \lambda_1$  and  $u(x) = \prod_{j=2}^{p-1} (1 - c_j x)^{\lambda_j}$  gives the following connection coefficients

$$\begin{aligned} c(0 : \lambda_0 + \mu \rightsquigarrow 1 : \lambda_1 + \mu) &= \frac{\Gamma(\lambda_0 + \mu + 1)\Gamma(-\lambda_1 - \mu)}{\Gamma(\lambda_0 + 1)\Gamma(-\lambda_1)} \prod_{j=2}^{p-1} (1 - c_j)^{\lambda_j}, \\ c(0 : \lambda_0 + \mu \rightsquigarrow 1 : 0) &= \frac{\Gamma(\lambda_0 + \mu + 1)}{\Gamma(\mu)\Gamma(\lambda_0 + 1)} \int_0^1 t^{\lambda_0} (1-t)^{\lambda_1 + \mu - 1} \prod_{j=2}^{p-1} (1 - c_j t)^{\lambda_j} dt \\ &= \frac{\Gamma(\lambda_0 + \mu + 1)\Gamma(\lambda_1 + \mu)}{\Gamma(\mu)\Gamma(\lambda_0 + \lambda_1 + \mu + 1)} F(\lambda_0 + 1, -\lambda_2, \lambda_0 + \lambda_1 + \mu + 1; c_2) \quad (p = 3). \end{aligned}$$

Here we have

$$(15.6) \quad u_0^{\lambda_0 + \mu}(x) = \sum_{k=0}^{\infty} C_k (x-1)^k + \sum_{k=0}^{\infty} C'_k (x-1)^{\lambda_1 + \mu + k}$$

for  $0 < x < 1$  with  $C_0 = c(0 : \lambda_0 + \mu \rightsquigarrow 1 : 0)$  and  $C'_0 = c(0 : \lambda_0 + \mu \rightsquigarrow 1 : \lambda_1 + \mu)$ .

Since  $\frac{d^k u_0^{\lambda_0 + \mu}}{dx^k}$  is a solution of the equation  $P_{P_p}(\lambda, \mu - k)u = 0$ , we have

$$(15.7) \quad C_k = \frac{\Gamma(\lambda_0 + \mu + 1)}{\Gamma(\mu - k)\Gamma(\lambda_0 + 1)k!} \int_0^1 t^{\lambda_0} (1-t)^{\lambda_1 + \mu - k - 1} \prod_{j=2}^{p-1} (1 - c_j t)^{\lambda_j} dt.$$

When  $p = 3$ ,

$$C_k = \frac{\Gamma(\lambda_0 + \mu + 1)\Gamma(\lambda_1 + \mu - k)}{\Gamma(\mu - k)\Gamma(\lambda_0 + \lambda_1 + \mu + 1 - k)k!} F(\lambda_0 + 1, -\lambda_2, \lambda_0 + \lambda_1 + \mu + 1 - k; c_2).$$

Put

$$u_{\lambda,\mu}(x) = \frac{1}{\Gamma(\mu)} \int_0^x \left( t^{\lambda_0} \prod_{j=1}^{p-1} (1 - c_j t)^{\lambda_j} \right) (x-t)^{\mu-1} dt = \partial^{-\mu} v_{\lambda},$$

$$v_{\lambda}(x) := x^{\lambda_0} \prod_{j=1}^{p-1} (1 - c_j x)^{\lambda_j}.$$

We have

$$(15.8) \quad \begin{aligned} u_{\lambda,\mu+1} &= \partial^{-\mu-1} v_{\lambda} = \partial^{-1} \partial^{-\mu} v_{\lambda} = \partial^{-1} u_{\lambda,\mu}, \\ u_{\lambda_0+1,\lambda_1,\dots,\mu} &= \partial^{-\mu} v_{\lambda_0+1,\lambda_1,\dots} = \partial^{-\mu} x v_{\lambda} = -\mu \partial^{-\mu-1} v_{\lambda} + x \partial^{-\mu} v_{\lambda} \\ &= -\mu \partial^{-1} u_{\lambda,\mu} + x u_{\lambda,\mu}, \\ u_{\dots,\lambda_j+1,\dots} &= \partial^{-\mu} (1 - c_j x) v_{\lambda} = \partial^{-\mu} v_{\lambda} + c_j \mu \partial^{-\mu-1} v_{\lambda} - c_j x \partial^{-\mu} v_{\lambda} \\ &= (1 - c_j x) u_{\lambda,\mu} + c_j \mu \partial^{-1} u_{\lambda,\mu}. \end{aligned}$$

From these relations with  $P_{P_p} u_{\lambda,\mu} = 0$  we have all the contiguity relations. For example

$$(15.9) \quad \begin{aligned} \partial u_{\lambda_0,\dots,\lambda_{p-1},\mu+1} &= u_{\lambda,\mu}, \\ \partial u_{\lambda_0+1,\dots,\lambda_{p-1},\mu} &= (x\partial + 1 - \mu) u_{\lambda,\mu}, \\ \partial u_{\dots,\lambda_j+1,\dots,\mu} &= ((1 - c_j x)\partial - c_j(1 - \mu)) u_{\lambda,\mu} \end{aligned}$$

and

$$\begin{aligned} P_{P_p}(\lambda, \mu + 1) &= \sum_{j=0}^{p-1} p_j(x) \partial^{p-j} + p_n \\ p_n &= (-1)^{p-1} c_1 \dots c_{p-1} \left( (-\mu - 1)_p + (-\mu)_{p-1} \sum_{j=0}^{p-1} \lambda_j \right) \\ &= c_1 \dots c_{p-1} (\mu + 2 - p)_{p-1} (\lambda_0 + \dots + \lambda_{p-1} - \mu - 1) \end{aligned}$$

and hence

$$\left( \sum_{j=0}^{p-1} p_j(x) \partial^{p-j-1} \right) u_{\lambda,\mu} = -p_n u_{\lambda,\mu+1} = -p_n \partial^{-1} u_{\lambda,\mu}.$$

Substituting this equation to (15.8), we have  $Q_j \in W(x; \lambda, \mu)$  such that  $Q_j u_{\lambda,\mu}$  equals  $u_{(\lambda_\nu + \delta_{\nu,j})_{\nu=0,\dots,p-1},\mu}$  for  $j = 0, \dots, p-1$ , respectively. The operators  $R_j \in W(x; \lambda, \mu)$  satisfying  $R_j Q_j u_{\lambda,\mu} = u_{\lambda,\mu}$  are calculated by the Euclid algorithm, namely, we find  $S_j \in W(x; \lambda, \mu)$  so that  $R_j Q_j + S_j P_{P_p} = 1$ . Thus we also have  $T_j \in W(x; \lambda, \mu)$  such that  $T_j u_{\lambda,\mu}$  equals  $u_{(\lambda_\nu - \delta_{\nu,j})_{\nu=0,\dots,p-1},\mu}$  for  $j = 0, \dots, p-1$ , respectively.

As is shown in §3.4 the Versal Jordan-Pochhammer operator  $\tilde{P}_{P_p}$  is given by (15.2) with

$$(15.10) \quad p_0(x) = \prod_{j=1}^p (1 - c_j x), \quad q(x) = \sum_{k=1}^p \lambda_k x^{k-1} \prod_{j=k+1}^p (1 - c_j x).$$

If  $c_1, \dots, c_p$  are different to each other, the Riemann scheme of  $\tilde{P}_{P_p}$  is

$$\left\{ \begin{array}{l} x = \frac{1}{c_j} \quad (j = 1, \dots, p) \\ [0]_{(p-1)} \\ \sum_{k=j}^p \frac{\lambda_k}{c_j \prod_{\substack{1 \leq \nu \leq k \\ \nu \neq j}} (c_j - c_\nu)} + \mu \quad \sum_{k=1}^p \frac{(-1)^k \lambda_k}{c_1 \dots c_k} - \mu \end{array} \right\}.$$



The solution of  $\tilde{P}_{P_p} u = 0$  is given by

$$u_C(x) = \int_C \left( \exp \int_0^t \sum_{j=1}^p \frac{-\lambda_j s^{j-1}}{\prod_{1 \leq \nu \leq j} (1 - c_\nu s)} ds \right) (x-t)^{\mu-1} dt.$$

Here the path  $C$  starting from a singular point and ending at a singular point is chosen so that the integration has a meaning. In particular when  $c_1 = \dots = c_p = 0$ , we have

$$u_C(x) = \int_C \exp \left( - \sum_{j=1}^p \frac{\lambda_j t^j}{j!} \right) (x-t)^{\mu-1} dt$$

and if  $\lambda_p \neq 0$ , the path  $C$  starts from  $\infty$  to one of the  $p$  independent directions  $\lambda_p^{-1} e^{\frac{2\pi\nu\sqrt{-1}}{p} + t}$  ( $t \gg 1$ ,  $\nu = 0, 1, \dots, p-1$ ) and ends at  $x$ .

Suppose  $n = 2$ . The corresponding Riemann scheme for the generic characteristic exponents and its construction from the Riemann scheme of the trivial equation  $u' = 0$  is as follows:

$$\left\{ \begin{array}{ccc} x = 0 & 1 & \infty \\ b_0 & c_0 & a_0 \\ b_1 & c_1 & a_1 \end{array} \right\} \quad (\text{Fuchs relation: } a_0 + a_1 + b_0 + b_1 + c_0 + c_1 = 1)$$

$$\leftarrow \frac{x^{b_0(1-x)^{c_0} \partial^{-a_1-b_1-c_1}}}{\left\{ \begin{array}{ccc} x = 0 & 1 & \infty \\ -a_1 - b_0 - c_1 & -a_1 - b_1 - c_0 & -a_0 + a_1 + 1 \end{array} \right\}}$$

$$\leftarrow \frac{x^{-a_1-b_0-c_1} (1-x)^{-a_1-b_1-c_0}}{\left\{ \begin{array}{ccc} x = 0 & 1 & \infty \\ 0 & 0 & 0 \end{array} \right\}}.$$

Then our fractional calculus gives the corresponding equation

$$(15.11) \quad \begin{aligned} & x^2(1-x)^2 u'' - x(1-x)((a_0 + a_1 + 1)x + b_0 + b_1 - 1)u' \\ & + (a_0 a_1 x^2 - (a_0 a_1 + b_0 b_1 - c_0 c_1)x + b_0 b_1)u = 0, \end{aligned}$$

the connection formula

$$(15.12) \quad c(0: b_1 \rightsquigarrow 1: c_1) = \frac{\Gamma(c_0 - c_1)\Gamma(b_1 - b_0 + 1)}{\Gamma(a_0 + b_1 + c_0)\Gamma(a_1 + b_1 + c_0)}$$

and expressions of its solution by the integral representation

$$(15.13) \quad \begin{aligned} & \int_0^x x^{b_0} (1-x)^{c_0} (x-s)^{a_1+b_1+c_1-1} s^{-a_1-c_1-b_0} (1-s)^{-a_1-b_1-c_0} ds \\ & = \frac{\Gamma(a_0 + b_1 + c_0)\Gamma(a_1 + b_1 + c_1)}{\Gamma(b_1 - b_0 + 1)} x^{b_1} \phi_{b_1}(x) \end{aligned}$$

and the series expansion

$$(15.14) \quad \begin{aligned} & \sum_{n \geq 0} \frac{(a_0 + b_1 + c_0)_n (a_1 + b_1 + c_0)_n}{(b_1 - b_0 + 1)_n n!} (1-x)^{c_0} x^{b_1+n} \\ & = (1-x)^{c_0} x^{b_1} F(a_0 + b_1 + c_0, a_1 + b_1 + c_0, b_1 - b_0 - 1; x). \end{aligned}$$

Here  $\phi_{b_1}(x)$  is a holomorphic function in a neighborhood of 0 satisfying  $\phi_{b_1}(0) = 1$  for generic spectral parameters. We note that the transposition of  $c_0$  and  $c_1$  in (15.14) gives a nontrivial equality, which corresponds to Kummer's relation of Gauss hypergeometric function and the similar statement is true for (15.13). In general different procedures of reduction of an equation give different expression of its solution.

#### 15.4. Hypergeometric family. $H_n$

We examine the hypergeometric family which corresponds to the equations satisfied by the generalized hypergeometric series (1.7). Its spectral type is in the Simpson's list (cf. §15.2).

$$\mathbf{m} = (1^n, n-11, 1^n) : {}_nF_{n-1}(\alpha, \beta; z)$$

$$n-11, 1^n, 1^n = 10, 1, 1 \oplus n-21, 1^{n-1}, 1^{n-1}$$

$$[\Delta(\mathbf{m})] = 1^{n^2}$$

$$H_n = H_1 \oplus H_{n-1} : n^2$$

$$H_n \xrightarrow[R2E0]{1} H_{n-1}$$

Since  $\mathbf{m}$  is of Okubo type, we have a system of Okubo normal form with the spectral type  $\mathbf{m}$ . Then the above  $R2E0$  represents the reduction of systems of equations of Okubo normal form due to Yokoyama [Yo2]. The number 1 on the arrow represents a reduction by a middle convolution and the number shows the difference of the orders.

$$\left\{ \begin{array}{ccc} x=0 & 1 & \infty \\ \lambda_{0,1} & [\lambda_{1,1}]_{(n-1)} & \lambda_{2,1} \\ \vdots & & \vdots \\ \lambda_{0,n-1} & & \lambda_{2,n-1} \\ \lambda_{0,n} & \lambda_{1,2} & \lambda_{2,n} \end{array} \right\}, \quad \left\{ \begin{array}{ccc} x=0 & 1 & \infty \\ 1-\beta_1 & [0]_{(n-1)} & \alpha_1 \\ \vdots & & \vdots \\ 1-\beta_{n-1} & & \alpha_{n-1} \\ 0 & -\beta_n & \alpha_n \end{array} \right\}$$

$$\sum_{\nu=1}^n (\lambda_{0,\nu} + \lambda_{2,\nu}) + (n-1)\lambda_{1,1} + \lambda_{1,2} = n-1,$$

$$\alpha_1 + \cdots + \alpha_n = \beta_1 + \cdots + \beta_n.$$

The Riemann scheme of the operator

$$P = \text{RAd}(\partial^{-\mu_{n-1}}) \circ \text{RAd}(x^{\gamma_{n-1}}) \circ \cdots \circ \text{RAd}(\partial^{-\mu_1}) \circ \text{RAd}(x^{\gamma_1}(1-x)^{\gamma'}) \partial$$

equals

$$(15.15) \quad \left\{ \begin{array}{ccc} x=0 & 1 & \infty \\ 0 & [0]_{(n-1)} & 1-\mu_{n-1} \\ (\gamma_{n-1} + \mu_{n-1}) & & 1 - (\gamma_{n-1} + \mu_{n-1}) - \mu_{n-2} \\ \sum_{j=n-2}^{n-1} (\gamma_j + \mu_j) & & 1 - \sum_{j=n-2}^{n-1} (\gamma_j + \mu_j) - \mu_{n-3} \\ \vdots & & \vdots \\ \sum_{j=2}^{n-1} (\gamma_j + \mu_j) & & 1 - \sum_{j=2}^{n-1} (\gamma_j + \mu_j) - \mu_1 \\ \sum_{j=1}^{n-1} (\gamma_j + \mu_j) & \gamma' + \sum_{j=1}^{n-1} \mu_j & -\gamma' - \sum_{j=1}^{n-1} (\gamma_j + \mu_j) \end{array} \right\},$$

which is obtained by the induction on  $n$  with Theorem 7.2 and corresponds to the second Riemann scheme in the above by putting

$$(15.16) \quad \begin{aligned} \gamma_j &= \alpha_{j+1} - \beta_j & (j=1, \dots, n-2), & \quad \gamma' = -\alpha_1 + \beta_1 - 1, \\ \mu_j &= -\alpha_{j+1} + \beta_{j+1} & (j=1, \dots, n-1), & \quad \mu_{n-1} = 1 - \alpha_n. \end{aligned}$$

The integral representation of the local solutions at  $x=0$  (resp. 1 and  $\infty$ ) corresponding to the exponents  $\sum_{j=1}^{n-1} (\gamma_j + \mu_j)$  (resp.  $\gamma' + \sum_{j=1}^{n-1} \mu_j$  and  $-\gamma' - \sum_{j=1}^{n-1} (\gamma_j + \mu_j)$ )

$\mu_j$ ) are given by

$$(15.17) \quad I_c^{\mu_{n-1}} x^{\gamma_{n-1}} I_c^{\mu_{n-2}} \cdots I_c^{\mu_1} x^{\gamma_1} (1-x)^{\gamma'}$$

by putting  $c = 0$  (resp. 1 and  $\infty$ ).

For simplicity we express this construction using additions and middle convolutions by

$$(15.18) \quad u = \partial^{-\mu_{n-1}} x^{\gamma_{n-1}} \cdots \partial^{-\mu_2} x^{\gamma_2} \partial^{-\mu_1} x^{\gamma_1} (1-x)^{\gamma'}$$

For example, when  $n = 3$ , we have the solution

$$\int_c^x t^{\alpha_3 - \beta_2} (x-t)^{1-\alpha_3} dt \int_c^t s^{\alpha_2 - \beta_1} (1-s)^{-\alpha_1 + \beta_1 - 1} (t-s)^{-\alpha_2 - \beta_2} ds.$$

The operator corresponding to the second Riemann scheme is

$$(15.19) \quad P_n(\alpha; \beta) := \prod_{j=1}^{n-1} (\vartheta - \beta_j) \cdot \partial - \prod_{j=1}^n (\vartheta - \alpha_j).$$

This is clear when  $n = 1$ . In general we have

$$\begin{aligned} & \text{RAd}(\partial^{-\mu}) \circ \text{RAd}(x^\gamma) P_n(\alpha, \beta) \\ &= \text{RAd}(\partial^{-\mu}) \circ \text{Ad}(x^\gamma) \left( \prod_{j=1}^{n-1} x(\vartheta + \beta_j) \cdot \partial - \prod_{j=1}^n x(\vartheta + \alpha_j) \right) \\ &= \text{RAd}(\partial^{-\mu}) \left( \prod_{j=1}^{n-1} (\vartheta + \beta_j - 1 - \gamma)(\vartheta - \gamma) - \prod_{j=1}^n x(\vartheta + \alpha_j - \gamma) \right) \\ &= \text{Ad}(\partial^{-\mu}) \left( \prod_{j=1}^{n-1} (\vartheta + \beta_j - \gamma) \cdot (\vartheta - \gamma + 1) \partial - \prod_{j=1}^n (\vartheta + 1)(\vartheta + \alpha_j - \gamma) \right) \\ &= \prod_{j=1}^{n-1} (\vartheta + \beta_j - \gamma - \mu) \cdot (\vartheta - \gamma - \mu + 1) \partial - \prod_{j=1}^n (\vartheta + 1 - \mu) \cdot (\vartheta + \alpha_j - \gamma - \mu) \end{aligned}$$

and therefore we have (15.19) by the correspondence of the Riemann schemes with  $\gamma = \gamma_n$  and  $\mu = \mu_n$ .

Suppose  $\lambda_{1,1} = 0$ . We will show that

$$(15.20) \quad \sum_{k=0}^{\infty} \frac{\prod_{j=1}^n (\lambda_{2,j} - \lambda_{0,n})_k}{\prod_{j=1}^{n-1} (\lambda_{0,n} - \lambda_{0,j} + 1)_k k!} x^{\lambda_{0,n} + k} \\ = x^{\lambda_{0,n}} {}_n F_{n-1}((\lambda_{2,j} - \lambda_{0,n})_{j=1, \dots, n}, (\lambda_{0,n} - \lambda_{0,j} + 1)_{j=1, \dots, n-1}; x)$$

is the local solution at the origin corresponding to the exponent  $\lambda_{0,n}$ . Here

$$(15.21) \quad {}_n F_{n-1}(\alpha_1, \dots, \alpha_n, \beta_1, \dots, \beta_{n-1}; x) = \sum_{k=0}^{\infty} \frac{(\alpha_1)_k \cdots (\alpha_{n-1})_k (\alpha_n)_k}{(\beta_1)_k \cdots (\beta_{n-1})_k k!} x^k.$$

We may assume  $\lambda_{0,1} = 0$  for the proof of (15.20). When  $n = 1$ , the corresponding solution equals  $(1-x)^{-\lambda_{2,1}}$  and we have (15.20). Note that

$$\begin{aligned} I_0^\mu x^\gamma & \sum_{k=0}^{\infty} \frac{\prod_{j=1}^n (\lambda_{2,j} - \lambda_{0,n})_k}{\prod_{j=1}^{n-1} (\lambda_{0,n} - \lambda_{0,j} + 1)_k k!} x^{\lambda_{0,n} + k} \\ & = \sum_{k=0}^{\infty} \frac{\prod_{j=1}^n (\lambda_{2,j} - \lambda_{0,n})_k}{\prod_{j=1}^{n-1} (\lambda_{0,n} - \lambda_{0,j} + 1)_k k!} \frac{\Gamma(\lambda_{0,n} + \gamma + k + 1)}{\Gamma(\lambda_{0,n} + \gamma + \mu + k + 1)} x^{\lambda_{0,n} + \gamma + \mu + k} \\ & = \frac{\Gamma(\lambda_{0,n} + \gamma + 1)}{\Gamma(\lambda_{0,n} + \gamma + \mu + 1)} \sum_{k=0}^{\infty} \frac{\prod_{j=1}^n (\lambda_{2,j} - \lambda_{0,n})_k \cdot (\lambda_{0,n} + \gamma + 1)_k \cdot x^{\lambda_{0,n} + \gamma + \mu + k}}{\prod_{j=1}^{n-1} (\lambda_{0,n} - \lambda_{0,j} + 1)_k \cdot (\lambda_{0,n} + \gamma + \mu + 1)_k k!}. \end{aligned}$$

Comparing (15.15) with the first Riemann scheme under  $\lambda_{0,1} = \lambda_{1,1} = 0$  and  $\gamma = \gamma_n$  and  $\mu = \mu_n$ , we have the solution (15.20) by the induction on  $n$ . The recurrence relation in Theorem 13.3 corresponds to the identity

$$(15.22) \quad \begin{aligned} & {}_n F_{n-1}(\alpha_1, \dots, \alpha_{n-1}, \alpha_n + 1; \beta_1, \dots, \beta_{n-1}; x) \\ & = {}_n F_{n-1}(\alpha_1, \dots, \alpha_n; \beta_1, \dots, \beta_{n-1}; x) \\ & \quad + \frac{\alpha_1 \cdots \alpha_{n-1}}{\beta_1 \cdots \beta_{n-1}} x \cdot {}_n F_{n-1}(\alpha_1 + 1, \dots, \alpha_n + 1; \beta_1 + 1, \dots, \beta_{n-1} + 1; x). \end{aligned}$$

The series expansion of the local solution at  $x = 1$  corresponding to the exponent  $\gamma' + \mu_1 + \cdots + \mu_{n-1}$  is a little more complicated.

For the Riemann scheme

$$\left\{ \begin{array}{ccc} x = \infty & 0 & 1 \\ -\mu_2 + 1 & [0]_{(2)} & 0 \\ 1 - \gamma_2 - \mu_1 - \mu_2 & & \gamma_2 + \mu_2 \\ -\gamma' - \gamma_1 - \gamma_2 - \mu_1 - \mu_2 & \underline{\gamma' + \mu_1 + \mu_2} & \gamma_1 + \gamma_2 + \mu_1 + \mu_2 \end{array} \right\},$$

we have the local solution at  $x = 0$

$$\begin{aligned} I_0^{\mu_2} (1-x)^{\gamma_2} I_0^{\mu_1} x^{\gamma'} (1-x)^{\gamma_1} & = I_0^{\mu_2} (1-x)^{\gamma_2} \sum_{n=0}^{\infty} \frac{(-\gamma_1)_n}{n!} x^n \\ & = I_0^{\mu_2} \sum_{n=0}^{\infty} \frac{\Gamma(\gamma' + 1 + n)(-\gamma_1)_n}{\Gamma(\gamma' + \mu_1 + 1 + n)n!} x^{\gamma' + \mu_1 + n} (1-x)^{\gamma_2} \\ & = I_0^{\mu_2} \sum_{m,n=0}^{\infty} \frac{\Gamma(\gamma' + 1 + n)(-\gamma_1)_n (-\gamma_2)_m}{\Gamma(\gamma' + \mu_1 + 1 + n)m!n!} x^{\gamma' + \mu_1 + m + n} \\ & = \sum_{m,n=0}^{\infty} \frac{\Gamma(\gamma' + \mu_1 + 1 + m + n)\Gamma(\gamma' + 1 + n)(-\gamma_1)_n (-\gamma_2)_m}{\Gamma(\gamma' + \mu_1 + \mu_2 + 1 + m + n)\Gamma(\gamma' + \mu_1 + 1 + n)m!n!} x^{\gamma' + \mu_1 + \mu_2 + m + n} \\ & = \frac{\Gamma(\gamma' + 1)x^{\gamma' + \mu_1 + \mu_2}}{\Gamma(\gamma' + \mu_1 + \mu_2 + 1)} \sum_{m,n=0}^{\infty} \frac{(\gamma' + \mu_1 + 1)_{m+n}(\gamma' + 1)_n (-\gamma_1)_n (-\gamma_2)_m x^{m+n}}{(\gamma' + \mu_1 + \mu_2 + 1)_{m+n}(\gamma' + \mu_1 + 1)_n m!n!}. \end{aligned}$$

Applying the last equality in (4.8) to the above second equality, we have

$$\begin{aligned} I_0^{\mu_2} (1-x)^{\gamma_2} I_0^{\mu_1} x^{\gamma'} (1-x)^{\gamma_1} & = \sum_{n=0}^{\infty} \frac{\Gamma(\gamma' + 1 + n)(-\gamma_1)_n}{\Gamma(\gamma' + \mu_1 + 1 + n)n!} x^{\gamma' + \mu_1 + \mu_2 + n} (1-x)^{-\gamma_2} \\ & \quad \cdot \sum_{m=0}^{\infty} \frac{\Gamma(\gamma' + \mu_1 + 1 + n)}{\Gamma(\gamma' + \mu_1 + \mu_2 + 1 + n)} \frac{(\mu_2)_m (-\gamma_2)_m}{(\gamma' + \mu_1 + n + \mu_2 + 1)_m m!} \left(\frac{x}{x-1}\right)^m \end{aligned}$$

$$\begin{aligned}
 &= \frac{\Gamma(\gamma' + 1)x^{\gamma'+\mu_1+\mu_2}(1-x)^{-\gamma_2}}{\Gamma(\gamma' + \mu_1 + \mu_2 + 1)} \sum_{m,n=0}^{\infty} \frac{(\gamma' + 1)_n(-\gamma_1)_n(-\gamma_2)_m(\mu_2)_m}{(\gamma' + \mu_1 + \mu_2 + 1)_{m+n}m!n!} x^n \left(\frac{x}{x-1}\right)^m \\
 &= \frac{\Gamma(\gamma' + 1)}{\Gamma(\gamma' + \mu_1 + \mu_2 + 1)} \\
 &\quad \cdot x^{\gamma'+\mu_1+\mu_2}(1-x)^{-\gamma_2} F_3(-\gamma_2, -\gamma_1, \mu_2, \gamma' + 1; \gamma' + \mu_1 + \mu_2 + 1; x, \frac{x}{x-1}),
 \end{aligned}$$

where  $F_3$  is Appell's hypergeometric function (15.49).

Let  $u_1^{-\beta_n}(\alpha_1, \dots, \alpha_n; \beta_1, \dots, \beta_{n-1}; x)$  be the local solution of  $P_n(\alpha, \beta)u = 0$  at  $x = 1$  such that  $u_1^{-\beta_n}(\alpha; \beta; x) \equiv (x-1)^{-\beta_n} \pmod{(x-1)^{1-\beta_n} \mathcal{O}_1}$  for generic  $\alpha$  and  $\beta$ . Since the reduction

$$\left\{ \begin{array}{ccc} \lambda_{0,1} & [0]_{(n-1)} & \lambda_{2,1} \\ \vdots & & \vdots \\ \lambda_{0,n} & \lambda_{1,2} & \lambda_{2,n} \end{array} \right\} \xrightarrow{\partial_{max}} \left\{ \begin{array}{ccc} \lambda'_{0,1} & [0]_{(n-2)} & \lambda'_{2,1} \\ \vdots & & \vdots \\ \lambda'_{0,n-1} & \lambda'_{1,2} & \lambda'_{2,n-1} \end{array} \right\}$$

satisfies  $\lambda'_{1,2} = \lambda_{1,2} + \lambda_{0,1} + \lambda_{0,2} - 1$  and  $\lambda'_{0,j} + \lambda'_{2,j} = \lambda_{0,j+1} + \lambda_{2,j+1}$  for  $j = 1, \dots, n-1$ , Theorem 13.3 proves

$$\begin{aligned}
 (15.23) \quad u_1^{-\beta_n}(\alpha; \beta; x) &= u_1^{-\beta_n}(\alpha_1, \dots, \alpha_n + 1; \beta_1, \dots, \beta_{n-1} + 1; x) \\
 &\quad + \frac{\beta_{n-1} - \alpha_n}{1 - \beta_n} u_1^{1-\beta_n}(\alpha; \beta_1, \dots, \beta_{n-1} + 1; x).
 \end{aligned}$$

The condition for the irreducibility of the equation equals

$$(15.24) \quad \lambda_{0,\nu} + \lambda_{1,1} + \lambda_{2,\nu'} \notin \mathbb{Z} \quad (1 \leq \nu \leq n, 1 \leq \nu' \leq n),$$

which is easily proved by the induction on  $n$  (cf. Example 12.17 ii). The shift operator under a compatible shift  $(\epsilon_{j,\nu})$  is bijective if and only if

$$(15.25) \quad \lambda_{0,\nu} + \lambda_{1,1} + \lambda_{2,\nu'} \quad \text{and} \quad \lambda_{0,\nu} + \epsilon_{0,\nu} + \lambda_{1,1} + \epsilon_{1,1} + \lambda_{2,\nu'} + \epsilon_{2,\nu'}$$

are simultaneously not integers or positive integers or non-positive integers for each  $\nu \in \{1, \dots, n\}$  and  $\nu' \in \{1, \dots, n\}$ .

Connection coefficients in this example are calculated by [Le] and [OTY] etc. In this paper we get them by Theorem 14.6.

There are the following direct decompositions ( $\nu = 1, \dots, n$ ).

$$\begin{aligned}
 1 \dots 1\bar{1}; n - 1\bar{1}; 1 \dots 1 &= 0 \dots 0\bar{1}; 1 \quad \overset{\nu}{0}; 0 \dots 010 \dots 0 \\
 &\quad \oplus 1 \dots 1\bar{0}; n - 2\bar{1}; 1 \dots 101 \dots 1.
 \end{aligned}$$

These  $n$  decompositions  $\mathbf{m} = \mathbf{m}' \oplus \mathbf{m}''$  satisfy the condition  $m'_{0,n_0} = m''_{1,n_1} = 1$  in (14.10), where  $n_0 = n$  and  $n_1 = 2$ . Since  $n_0 + n_1 - 2 = n$ , Remark 14.8 i) shows that these decompositions give all the decompositions appearing in (14.10). Thus we have

$$\begin{aligned}
 c(\lambda_{0,n} \rightsquigarrow \lambda_{1,2}) &= \frac{\prod_{\nu=1}^{n-1} \Gamma(\lambda_{0,n} - \lambda_{0,\nu} + 1) \cdot \Gamma(\lambda_{1,1} - \lambda_{1,2})}{\prod_{\nu=1}^n \Gamma(\lambda_{0,n} + \lambda_{1,1} + \lambda_{2,\nu})} = \prod_{\nu=1}^n \frac{\Gamma(\beta_\nu)}{\Gamma(\alpha_\nu)} \\
 &= \lim_{x \rightarrow 1-0} (1-x)^{\beta_n} {}_nF_{n-1}(\alpha, \beta; x) \quad (\text{Re } \beta_n > 0).
 \end{aligned}$$

Other connection coefficients are obtained by the similar way.

$c(\lambda_{0,n} \rightsquigarrow \lambda_{2,n})$ : When  $n = 3$ , we have

$$\begin{aligned} 11\bar{1}, 21, 11\underline{1} &= 001, 10, 100 \quad 001, 10, 010 \quad 101, 11, 110 \quad 011, 11, 110 \\ &\oplus 110, 11, 011 = 110, 11, 101 = 010, 10, 001 = 100, 10, 001 \end{aligned}$$

In general by the rigid decompositions

$$\begin{aligned} 1 \cdots 1\bar{1}, n-11, 1 \cdots 1\underline{1} &= 0 \cdots 0\bar{1}, \quad \begin{matrix} 1 & 0 & 0 \cdots 0 & 10 \cdots 00 \\ \oplus & 1 \cdots 10, & n-21, & 1 \cdots 101 \cdots 1\underline{1} \end{matrix} \\ &= 1 \cdots 10\underline{1} \cdots 1\bar{1}, n-21, 1 \cdots 10 \\ &\oplus 0 \cdots 010 \cdots 00, \quad \begin{matrix} 1 & 0 & 0 \cdots 0 \\ \oplus & 1 & 0 & 0 \cdots 0 \end{matrix} \end{aligned}$$

for  $i = 1, \dots, n-1$  we have

$$\begin{aligned} c(\lambda_{0,n} \rightsquigarrow \lambda_{2,n}) &= \prod_{k=1}^{n-1} \frac{\Gamma(\lambda_{2,k} - \lambda_{2,n})}{\Gamma(|\{\lambda_{0,n} \quad \lambda_{1,1} \quad \lambda_{2,k}\}|)} \\ &\quad \cdot \prod_{k=1}^{n-1} \frac{\Gamma(\lambda_{0,n} - \lambda_{0,k} + 1)}{\Gamma\left(\left\{ \begin{array}{c} (\lambda_{0,\nu})_{1 \leq \nu \leq n} \\ \nu \neq k \end{array} \right\} \begin{array}{c} [\lambda_{1,1}]_{(n-2)} \\ \lambda_{1,2} \end{array} \begin{array}{c} (\lambda_{2,\nu})_{1 \leq \nu \leq n-1} \end{array} \right)} \\ &= \prod_{k=1}^{n-1} \frac{\Gamma(\beta_k) \Gamma(\alpha_k - \alpha_n)}{\Gamma(\alpha_k) \Gamma(\beta_k - \alpha_n)}. \end{aligned}$$

Moreover we have

$$\begin{aligned} c(\lambda_{1,2} \rightsquigarrow \lambda_{0,n}) &= \frac{\Gamma(\lambda_{1,2} - \lambda_{1,1} + 1) \cdot \prod_{\nu=1}^{n-1} \Gamma(\lambda_{0,\nu} - \lambda_{0,n})}{\prod_{j=1}^n \Gamma\left(\left\{ \begin{array}{c} (\lambda_{0,\nu})_{1 \leq \nu \leq n-1} \\ \nu \neq j \end{array} \right\} \begin{array}{c} [\lambda_{1,1}]_{(n-2)} \\ \lambda_{1,2} \end{array} \begin{array}{c} (\lambda_{2,\nu})_{1 \leq \nu \leq n, \nu \neq j} \end{array} \right)} \\ &= \prod_{\nu=1}^n \frac{\Gamma(1 - \beta_\nu)}{\Gamma(1 - \alpha_\nu)}. \end{aligned}$$

Here we denote

$$(\mu_\nu)_{1 \leq \nu \leq n} = \begin{pmatrix} \mu_1 \\ \mu_2 \\ \vdots \\ \mu_n \end{pmatrix} \in \mathbb{C}^n \quad \text{and} \quad (\mu_\nu)_{\substack{1 \leq \nu \leq n \\ \nu \neq i}} = \begin{pmatrix} \mu_1 \\ \vdots \\ \mu_{i-1} \\ \mu_{i+1} \\ \vdots \\ \mu_n \end{pmatrix} \in \mathbb{C}^{n-1}$$

for complex numbers  $\mu_1, \dots, \mu_n$ .

These connection coefficients were obtained by [Le] and [Yos] etc.

We have

$$\begin{aligned} (15.26) \quad {}_n F_{n-1}(\alpha, \beta; x) &= \sum_{k=0}^{\infty} C_k (1-x)^k + \sum_{k=0}^{\infty} C'_k (1-x)^{k-\beta_n}, \\ C_0 &= {}_n F_{n-1}(\alpha, \beta; 1) \quad (\operatorname{Re} \beta_n < 0), \\ C'_0 &= \prod_{\nu=1}^n \frac{\Gamma(\beta_\nu)}{\Gamma(\alpha_\nu)} \end{aligned}$$

for  $0 < x < 1$  if  $\alpha$  and  $\beta$  are generic. Since

$$\begin{aligned} \frac{d^k}{dx^k} {}_nF_{n-1}(\alpha, \beta; x) \\ = \frac{(\alpha_1)_k \cdots (\alpha_n)_k}{(\beta_1)_k \cdots (\beta_{n-1})_k} {}_nF_{n-1}(\alpha_1 + k, \dots, \alpha_n + k, \beta_1 + k, \dots, \beta_{n-1} + k; x), \end{aligned}$$

we have

$$(15.27) \quad C_k = \frac{(\alpha_1)_k \cdots (\alpha_n)_k}{(\beta_1)_k \cdots (\beta_{n-1})_k k!} {}_nF_{n-1}(\alpha_1 + k, \dots, \alpha_n + k, \beta_1 + k, \dots, \beta_{n-1} + k; 1).$$

We examine the monodromy generators for the solutions of the generalized hypergeometric equation. For simplicity we assume  $\beta_i \notin \mathbb{Z}$  and  $\beta_i - \beta_j \notin \mathbb{Z}$  for  $i \neq j$ . Then  $u = (u_0^{\lambda_{0,1}}, \dots, u_0^{\lambda_{0,n}})$  is a base of local solution at 0 and the corresponding monodromy generator around 0 with respect to this base equals

$$M_0 = \begin{pmatrix} e^{2\pi\sqrt{-1}\lambda_{0,1}} & & \\ & \ddots & \\ & & e^{2\pi\sqrt{-1}\lambda_{0,n}} \end{pmatrix}$$

and that around  $\infty$  equals

$$\begin{aligned} M_\infty &= \left( \sum_{k=1}^n e^{2\pi\sqrt{-1}\lambda_{2,\nu}} c(\lambda_{0,i} \rightsquigarrow \lambda_{2,k}) c(\lambda_{2,k} \rightsquigarrow \lambda_{k,j}) \right)_{\substack{1 \leq i \leq n \\ 1 \leq j \leq n}} \\ &= \left( \sum_{k=1}^n e^{2\pi\sqrt{-1}\lambda_{2,\nu}} \prod_{\nu \in \{1, \dots, n\} \setminus \{k\}} \frac{\sin 2\pi(\lambda_{0,i} + \lambda_{1,1} + \lambda_{2,\nu})}{\sin 2\pi(\lambda_{0,k} - \lambda_{0,\nu})} \right. \\ &\quad \cdot \left. \prod_{\nu \in \{1, \dots, n\} \setminus \{j\}} \frac{\sin 2\pi(\lambda_{0,i} + \lambda_{1,1} + \lambda_{2,\nu})}{\sin 2\pi(\lambda_{2,j} - \lambda_{2,\nu})} \right)_{\substack{1 \leq i \leq n \\ 1 \leq j \leq n}}. \end{aligned}$$

Lastly we remark that the versal generalized hypergeometric operator is

$$\begin{aligned} \tilde{P} &= \text{RAd}(\partial^{-\mu_{n-1}}) \circ \text{RAd}\left((1 - c_1x)^{\frac{\gamma_{n-1}}{c_1}}\right) \circ \cdots \circ \text{RAd}(\partial^{-\mu_1}) \\ &\quad \circ \text{RAd}\left((1 - c_1x)^{\frac{\gamma_1}{c_1} + \frac{\gamma'}{c_1(c_1 - c_2)}} (1 - c_2x)^{\frac{\gamma'}{c_2(c_2 - c_1)}}\right) \partial \\ &= \text{RAd}(\partial^{-\mu_{n-1}}) \circ \text{RAd}\text{ei}\left(\frac{\gamma_{n-1}}{1 - c_1x}\right) \circ \cdots \circ \text{RAd}(\partial^{-\mu_1}) \\ &\quad \circ \text{RAd}\text{ei}\left(\frac{\gamma_1}{1 - c_1x} + \frac{\gamma'x}{(1 - c_1x)(1 - c_2x)}\right) \partial \end{aligned}$$

and when  $n = 3$ , we have the integral representation of the solutions

$$\int_c^x \int_c^t \exp\left(-\int_c^s \frac{\gamma_1(1 - c_2u) + \gamma'u}{(1 - c_1u)(1 - c_2u)} du\right) (t - s)^{\mu_1 - 1} (1 - c_1t)^{\frac{\gamma_2}{c_1}} (x - t)^{\mu_2 - 1} ds dt.$$

Here  $c$  equals  $\frac{1}{c_1}$  or  $\frac{1}{c_2}$  or  $\infty$ .

### 15.5. Even/Odd family. $EO_n$

The system of differential equations of Schlesinger canonical form belonging to an even or odd family is concretely given by [Gl]. We will examine concrete connection coefficients of solutions of the single differential equation belonging to an even or odd family. The corresponding tuples of partitions and their reductions and

decompositions are as follows.

$$\begin{aligned} m + 1m, m^2 1, 1^{2m+1} &= 10, 10, 1 \oplus m^2, mm - 11, 1^{2m} \\ &= 1^2, 1^2 0, 1^2 \oplus mm - 1, (m-2)^2 1, 1^{2m-1} \\ m^2, mm - 11, 1^{2m} &= 1, 100, 1 \oplus mm - 1, (m-1)^2 1, 1^{2m-1} \\ &= 1^2, 110, 1^2 \oplus (m-1)^2, m-1m-21, 1^{2m-2} \\ EO_n &= H_1 \oplus EO_{n-1} : 2n = H_2 \oplus EO_{n-2} : \binom{n}{2} \end{aligned}$$

$$[\Delta(\mathbf{m})] = 1^{\binom{n}{2} + 2n}$$

$$EO_n \xrightarrow[R_1 E_0 R_0 E_0]{1} EO_{n-1}$$

$$EO_2 = H_2, \quad EO_3 = H_3$$

$EO_{2m}$  ( $\mathbf{m} = (1^{2m}, mm - 11, mm)$ ) : even family)

$$\left\{ \begin{array}{ccc} x = \infty & 0 & 1 \\ \lambda_{0,1} & [\lambda_{1,1}]_{(m)} & [\lambda_{2,1}]_{(m)} \\ \vdots & [\lambda_{1,2}]_{(m-1)} & [\lambda_{2,2}]_{(m)} \\ \lambda_{0,2m} & \lambda_{1,3} & \end{array} \right\},$$

$$\sum_{\nu=1}^{2m} \lambda_{0,\nu} + m(\lambda_{1,1} + \lambda_{2,1} + \lambda_{2,2}) + (m-1)\lambda_{1,2} + \lambda_{1,3} = 2m - 1.$$

The rigid decompositions

$$\begin{aligned} 1 \cdots 1\bar{1}, mm - 1\bar{1}, mm \\ &= 0 \cdots 0\bar{1}, 10\bar{0}, 10 \oplus 1 \cdots 1\bar{0}, m - 1m - 1\bar{1}, 0\bar{1} \\ &= 0 \cdots 1\bar{1}, 11\bar{0}, 11 \oplus 1 \cdots 0\bar{0}, m - 1m - 2\bar{1}, m - 1m - 1, \end{aligned}$$

which are expressed by  $EO_{2m} = H_1 \oplus EO_{2m-1} = H_2 \oplus EO_{2m-2}$ , give

$$c(\lambda_{0,2m} \rightsquigarrow \lambda_{1,3}) = \prod_{i=1}^2 \frac{\Gamma(\lambda_{1,i} - \lambda_{1,3})}{\Gamma(|\{\lambda_{0,2m} \quad \lambda_{1,1} \quad \lambda_{2,i}\}|)} \cdot \prod_{j=1}^{2m-1} \frac{\Gamma(\lambda_{0,2m} - \lambda_{0,j} + 1)}{\Gamma(|\{\lambda_{0,j} \quad \lambda_{1,1} \quad \lambda_{2,1}\}|)},$$

$$\begin{aligned} c(\lambda_{1,3} \rightsquigarrow \lambda_{0,2m}) &= \prod_{i=1}^2 \frac{\Gamma(\lambda_{1,3} - \lambda_{1,i} + 1)}{\Gamma(|\left\{ \begin{array}{ccc} (\lambda_{0,\nu})_{1 \leq \nu \leq 2m-1} & [\lambda_{1,1}]_{(m-1)} & [\lambda_{2,\nu}]_{(m)} \\ & [\lambda_{1,2}]_{(m-1)} & [\lambda_{2,3-i}]_{(m-1)} \\ & \lambda_{1,3} & \end{array} \right\}|)} \\ &\cdot \prod_{j=1}^{2m-1} \frac{\Gamma(\lambda_{0,j} - \lambda_{0,2m})}{\Gamma(|\left\{ \begin{array}{ccc} (\lambda_{0,\nu})_{1 \leq \nu \leq 2m-1} & [\lambda_{1,1}]_{(m-1)} & [\lambda_{2,1}]_{(m-1)} \\ & [\lambda_{1,2}]_{(m-2)} & [\lambda_{2,2}]_{(m-1)} \\ & \lambda_{1,3} & \end{array} \right\}|)}. \end{aligned}$$

These formulas were obtained by the author in 2007 (cf. [O6]), which is a main motivation for the study in this paper. The condition for the irreducibility is

$$\begin{cases} \lambda_{0,\nu} + \lambda_{1,1} + \lambda_{2,k} \notin \mathbb{Z} & (1 \leq \nu \leq 2m, k = 1, 2), \\ \lambda_{0,\nu} + \lambda_{0,\nu'} + \lambda_{1,1} + \lambda_{1,2} + \lambda_{2,1} + \lambda_{2,2} - 1 \notin \mathbb{Z} & (1 \leq \nu < \nu' \leq 2m, k = 1, 2). \end{cases}$$

The shift operator for a compatible shift  $(\epsilon_{j,\mu})$  is bijective if and only if the values of each linear function in the above satisfy (13.27).



For the Fuchsian equation  $\tilde{P}u = 0$  of type  $EO_4$  with the Riemann scheme

$$(15.28) \quad \left\{ \begin{array}{ccc} x = \infty & 0 & 1 \\ [a_1]_{(2)} & b_1 & [0]_{(2)} ; x \\ [a_2]_{(2)} & b_2 & c_1 \\ & b_3 & c_2 \\ & 0 & \end{array} \right\}$$

and the Fuchs relation

$$(15.29) \quad 2a_1 + 2a_2 + b_1 + b_2 + b_3 + c_1 + c_2 = 3$$

we have the connection formula

$$(15.30) \quad c(0:0 \rightsquigarrow 1:c_2) = \frac{\Gamma(c_1 - c_2)\Gamma(-c_2)\prod_{\nu=1}^3\Gamma(1 - b_\nu)}{\Gamma(a_1)\Gamma(a_2)\prod_{\nu=1}^3\Gamma(a_1 + a_2 + b_\nu + c_1 - 1)}.$$

Let  $\tilde{Q}$  be the Gauss hypergeometric operator with the Riemann scheme

$$\left\{ \begin{array}{ccc} x = \infty & 0 & 1 \\ a_1 & 1 - a_1 - a_2 - c_1 & 0 \\ a_2 & 0 & c_1 \end{array} \right\}.$$

We may normalize the operators by

$$\tilde{P} = x^3(1-x)\partial^4 + \dots \quad \text{and} \quad \tilde{Q} = x(1-x)\partial^2 + \dots.$$

Then

$$\tilde{P} = \tilde{S}\tilde{Q} - \prod_{\nu=1}^3(a_1 + a_2 + b_\nu + c_1 - 1) \cdot \partial$$

with a suitable  $\tilde{S} \in W[x]$  and  $\tilde{Q}$  is a shift operator satisfying

$$\left\{ \begin{array}{ccc} x = \infty & 0 & 1 \\ [a_1]_{(2)} & b_1 & [0]_{(2)} ; x \\ [a_2]_{(2)} & b_2 & c_1 \\ & b_3 & c_2 \\ & 0 & \end{array} \right\} \xrightarrow{\tilde{Q}} \left\{ \begin{array}{ccc} x = \infty & 0 & 1 \\ [a_1 + 1]_{(2)} & b_1 - 1 & [0]_{(2)} ; x \\ [a_2 + 1]_{(2)} & b_2 - 1 & c_1 \\ & b_3 - 1 & c_2 - 1 \\ & 0 & \end{array} \right\}.$$

Let  $u_0^0 = 1 + \dots$  and  $u_1^{c_2} = (1-x)^{c_2} + \dots$  be the normalized local solutions of  $\tilde{P}u = 0$  corresponding to the characteristic exponents 0 at 0 and  $c_2$  at 1, respectively. Then the direct calculation shows

$$\begin{aligned} \tilde{Q}u_0^0 &= \frac{a_1 a_2 \prod_{\nu=1}^3 (a_1 + a_2 + b_\nu + c_1 - 1)}{\prod_{\nu=1}^3 (1 - b_\nu)} + \dots, \\ \tilde{Q}u_1^{c_2} &= c_2(c_2 - c_1)(1-x)^{c_2-1} + \dots. \end{aligned}$$

Denoting by  $c(a_1, a_2, b_1, b_2, b_3, c_1, c_2)$  the connection coefficient  $c(0:0 \rightsquigarrow 1:c_2)$  for the equation with the Riemann scheme (15.28), we have

$$\frac{c(a_1, a_2, b_1, b_2, b_3, c_1, c_2)}{c(a_1 + 1, a_2 + 1, b_1 - 1, b_2 - 1, b_3 - 1, c_1, c_2 - 1)} = \frac{a_1 a_2 \prod_{\nu=1}^3 (a_1 + a_2 + b_\nu + c_1 - 1)}{(c_1 - c_2)(-c_2) \prod_{\nu=1}^3 (1 - b_\nu)},$$

which proves (15.30) since  $\lim_{k \rightarrow \infty} c(a_1 + k, a_2 + k, b_1 - k, b_2 - k, b_3 - k, c_1, c_2 - k) = 1$ .

By the transformation  $x \mapsto \frac{x}{x-1}$  we have

$$\begin{aligned} & \left\{ \begin{array}{ccc} x = \infty & 0 & 1 \\ [0]_{(2)} & 0 & [a_1]_{(2)} \\ c_1 & b_1 & [a_2]_{(2)} \\ c_2 & b_2 & \\ & b_3 & \end{array} \right\} \\ & \xrightarrow{(1-x)^{a_1} \partial^{1-a_1} (1-x)^{-a_1}} \left\{ \begin{array}{ccc} x = \infty & 0 & 1 \\ 2-2a_1 & & a_1 \\ 1+c_1-a_1 & a_1+b_1-1 & [a_1+a_2-1]_{(2)} \\ 1+c_2-a_1 & a_1+b_2-1 & \\ & a_1+b_3-1 & \end{array} \right\} \\ & \xrightarrow{x^{1-a_1-b_1} (1-x)^{1-a_1-a_2}} \left\{ \begin{array}{ccc} x = \infty & 0 & 1 \\ a_2+b_1 & & 1-a_2 \\ a_1+a_2+b_1+c_1-1 & 0 & [0]_{(2)} \\ a_1+a_2+b_1+c_2-1 & b_2-b_1 & \\ & b_3-b_1 & \end{array} \right\} \end{aligned}$$

and therefore Theorem 14.4 gives the following connection formula for (15.28):

$$\begin{aligned} c(0:b_1 \rightsquigarrow \infty:a_2) &= \frac{\Gamma(b_1+1)\Gamma(a_1-a_2)}{\Gamma(a_1+b_1)\Gamma(1-a_2)} \cdot {}_3F_2(a_2+b_1, a_1+a_2+b_1+c_1-1, \\ & \quad a_1+a_2+b_1+c_2-1; b_1-b_2-1, b_1-b_3-1; 1). \end{aligned}$$

In the same way, we have

$$\begin{aligned} c(1:c_1 \rightsquigarrow \infty:a_2) &= \frac{\Gamma(c_1+1)\Gamma(a_1-a_2)}{\Gamma(a_1+c_1)\Gamma(1-a_2)} \cdot {}_3F_2(b_1-c_1, b_2-c_1, b_3-c_1; \\ & \quad a_1+c_1, c_1-c_2+1; 1). \end{aligned}$$

We will calculate generalized connection coefficients defined in Definition 14.17. In fact, we get

$$(15.31) \quad c(1:[0]_{(2)} \rightsquigarrow \infty:[a_2]_{(2)}) = \frac{\prod_{\nu=1}^2 \Gamma(2-c_\nu) \cdot \prod_{i=1}^2 \Gamma(a_1-a_2+i)}{\Gamma(a_1) \prod_{\nu=1}^3 \Gamma(a_1+b_\nu)},$$

$$(15.32) \quad c(\infty:[a_2]_{(2)} \rightsquigarrow 1:[0]_{(2)}) = \frac{\prod_{\nu=1}^2 \Gamma(c_\nu-1) \cdot \prod_{i=0}^1 \Gamma(a_2-a_1-i)}{\Gamma(1-a_1) \prod_{\nu=1}^3 \Gamma(1-a_1-b_\nu)}$$

according to the procedure given in Remark 14.19, which we will explain.

The differential equation with the Riemann scheme  $\left\{ \begin{array}{ccc} x = \infty & 0 & 1 \\ \alpha_1 & [0]_{(2)} & [0]_{(2)} \\ \alpha_2 & [\beta]_{(2)} & \gamma_1 \\ \alpha_3 & & \gamma_2 \\ \alpha_4 & & \end{array} \right\}$  is

$Pu = 0$  with

$$(15.33) \quad \begin{aligned} P &= \prod_{j=1}^4 (\vartheta + \alpha_j) + \vartheta(\vartheta - \beta) ((\vartheta - 2\vartheta + \gamma_1 + \gamma_2 - 1)(\vartheta - \beta) \\ & \quad + \sum_{1 \leq i < j \leq 3} \alpha_i \alpha_j - (\beta - 2\gamma_1 - 2\gamma_2 - 4)(\beta - 1) - \gamma_1 \gamma_2 + 1). \end{aligned}$$

The equation  $Pu = 0$  is isomorphic to the system

$$(15.34) \quad \frac{d\tilde{u}}{dx} = \frac{A}{x}\tilde{u} + \frac{B}{x-1}\tilde{u},$$

$$A = \begin{pmatrix} 0 & 0 & 1 & 0 \\ 0 & 0 & 0 & 1 \\ 0 & 0 & c & 0 \\ 0 & 0 & 0 & c \end{pmatrix}, \quad B = \begin{pmatrix} 0 & 0 & 0 & 0 \\ 0 & 0 & 0 & 0 \\ s & 1 & a & 0 \\ r & t & 0 & b \end{pmatrix}, \quad \tilde{u} = \begin{pmatrix} u_1 \\ u_2 \\ u_3 \\ u_4 \end{pmatrix}$$

by the correspondence

$$\begin{cases} u_1 = u, \\ u_2 = (x-1)xu'' + ((1-a-c)x + a-1)u' - su, \\ u_3 = xu', \\ u_4 = x^2(x-1)u''' + ((3-a-c)x^2 + (a-2)x)u'' + (1-a-c-s)xu', \end{cases}$$

where we may assume  $\operatorname{Re} \gamma_1 \geq \operatorname{Re} \gamma_2$  and

$$\beta = c, \quad \gamma_1 = a + 1, \quad \gamma_2 = b + 2,$$

$$\prod_{\nu=1}^4 (\xi - \alpha_\nu) = \xi^4 + (a+b+2c)\xi^3 + ((a+c)(b+c) - s-t)\xi^2 - ((b+c)s + (a+c)t)\xi + st - r.$$

Here  $s, t$  and  $r$  are uniquely determined from  $\alpha_1, \alpha_2, \alpha_3, \alpha_4, \beta, \gamma_1, \gamma_2$  because  $b+c \neq a+c$ . We remark that  $\operatorname{Ad}(x^{-c})\tilde{u}$  satisfies a system of Okubo normal form.

Note that the shift of parameters  $(\alpha_1, \dots, \alpha_4, \beta, \gamma_1, \gamma_2) \mapsto ((\alpha_1, \dots, \alpha_4, \beta-1, \gamma_1+1, \gamma_2+1)$  corresponds to the shift  $(a, b, c, s, t, r) \mapsto (a+1, b+1, c-1, s, t, r)$ .

Let  $u_{\alpha_1, \dots, \alpha_4, \beta, \gamma_1, \gamma_2}^j(x)$  be local holomorphic solutions of  $Pu = 0$  in a neighborhood of  $x = 0$  determined by

$$\begin{aligned} u_{\alpha_1, \dots, \alpha_4, \beta, \gamma_1, \gamma_2}^j(0) &= \delta_{j,0}, \\ \left(\frac{d}{dx} u_{\alpha_1, \dots, \alpha_4, \beta, \gamma_1, \gamma_2}^j\right)(0) &= \delta_{j,1} \end{aligned}$$

for  $j = 0$  and  $1$ . Then Theorem 14.10 proves

$$\lim_{k \rightarrow \infty} \frac{d^\nu}{dx^\nu} u_{\alpha, \beta-k, \gamma_1+k, \gamma_1+k}^0(x) = \delta_{0,\nu} \quad (\nu = 0, 1, 2, \dots)$$

uniformly on  $\overline{D} = \{x \in \mathbb{C}; |x| \leq 1\}$ .

Put  $u = v_{\alpha, \beta, \gamma_1, \gamma_2} = (\gamma_1 - 2)^{-1} u_{\alpha, \beta, \gamma}^1$ . Then Theorem 14.10 proves

$$\lim_{k \rightarrow \infty} \frac{d^\nu}{dx^\nu} v_{\alpha, \beta-k, \gamma_1+k, \gamma_2+k}(x) = 0 \quad (\nu = 0, 1, 2, \dots),$$

$$\lim_{k \rightarrow \infty} \left( (x-1)x \frac{d^2}{dx^2} + ((2-\beta-\gamma_1)x + \gamma_1 + k - 2) \frac{d}{dx} - s \right) v_{\alpha, \beta-k, \gamma_1+k, \gamma_2+k}(x) = 1$$

uniformly on  $\overline{D}$ . Hence

$$\lim_{k \rightarrow \infty} \left( \frac{d}{dx} u_{\alpha, \beta-k, \gamma+1, \gamma_1+k}^1 \right)(x) = 1$$

uniformly on  $\overline{D}$ . Thus we obtain

$$\lim_{k \rightarrow \infty} c(\infty: [a_2]_{(2)} \rightsquigarrow 1: [0]_{(2)})|_{a_1 \mapsto a_1-k, c_1 \mapsto c_1+k, c_2 \mapsto c_2+k} = 1$$

for the connection coefficient in (15.32). Then the procedure given in Remark 14.19 and Corollary 14.22 with the rigid decompositions

$$\begin{aligned} \underline{22}, \underline{1111}, \overline{211} &= \underline{12}, \underline{0111}, \overline{111} \oplus \underline{10}, \underline{1000}, \underline{100} = \underline{12}, \underline{1011}, \overline{111} \oplus \underline{10}, \underline{0100}, \overline{100} \\ &= \underline{12}, \underline{1101}, \overline{111} \oplus \underline{10}, \underline{0010}, \overline{100} = \underline{12}, \underline{1101}, \overline{111} \oplus \underline{10}, \underline{0010}, \overline{100} \end{aligned}$$

prove (15.32). Corresponding to Remark 14.19 (4) we note

$$\sum_{\nu=1}^2 (c_\nu - 1) + \sum_{i=0}^1 (a_2 - a_1 - i) = (1 - a_1) + \sum_{\nu=1}^3 \Gamma(1 - a_1 - b_\nu)$$

because of the Fuchs relation (15.29). We can similarly obtain (15.31).

The holomorphic solution at the origin is given by

$$u_0(x) = \sum_{m \geq 0, n \geq 0} \frac{(a_1 + a_2 + b_3 + c_2 - 1)_n \prod_{\nu=1}^2 ((a_\nu)_{m+n} (a_1 + a_2 + b_\nu + c_1 - 1)_m)}{(1 - b_1)_{m+n} (1 - b_2)_{m+n} (1 - b_3)_m m! n!} x^{m+n}$$

and it has the integral representation

$$u_0(x) = \frac{\prod_{\nu=1}^3 \Gamma(1 - b_\nu)}{\prod_{\nu=1}^2 (\Gamma(a_\nu) \Gamma(1 - a_\nu - b_\nu) \Gamma(b_\nu + c_\nu + a_1 + a_2 - 1))} \int_0^x \int_0^{s_0} \int_0^{s_1} x^{b_1} (x - s_0)^{-b_1 - a_1} s_0^{b_2 + a_1 - 1} (s_0 - s_1)^{-b_2 - a_2} \cdot s_1^{b_3 + a_2 - 1} (1 - s_1)^{-b_3 - c_1 - a_2 - a_1 + 1} (s_1 - s_2)^{c_1 + b_1 + a_2 + a_1 - 2} \cdot s_2^{b_2 + c_2 + a_2 + a_1 - 2} (1 - s_2)^{-c_2 - b_1 - a_2 - a_1 + 1} ds_2 ds_1 ds_0.$$

The equation is irreducible if and only if any value of the following linear functions is not an integer.

$$\begin{array}{ccccccc} a_1 & a_2 & & & & & \\ a_1 + b_1 & a_1 + b_2 & a_1 + b_3 & a_2 + b_1 & a_2 + b_2 & a_2 + b_3 & \\ a_1 + a_2 + b_1 + c_1 - 1 & a_1 + a_2 + b_1 + c_2 - 1 & a_1 + a_2 + b_2 + c_1 - 1 & & & & \\ a_1 + a_2 + b_2 + c_2 - 1 & a_1 + a_2 + b_3 + c_1 - 1 & a_1 + a_2 + b_2 + c_2 - 1. & & & & \end{array}$$

In the same way we have the connection coefficients for odd family.

$EO_{2m+1}(\mathbf{m} = (1^{2m+1}, mm1, m + 1m) : \text{odd family})$

$$\left\{ \begin{array}{ccc} x = \infty & 0 & 1 \\ \lambda_{0,1} & [\lambda_{1,1}]_{(m)} & [\lambda_{2,1}]_{(m+1)} \\ \vdots & [\lambda_{1,2}]_{(m)} & [\lambda_{2,2}]_{(m)} \\ \lambda_{0,2m+1} & \lambda_{1,3} & \end{array} \right\}$$

$$\sum_{\nu=1}^{2m+1} \lambda_{0,\nu} + m(\lambda_{1,1} + \lambda_{1,2} + \lambda_{2,2}) + (m+1)\lambda_{2,1} + \lambda_{1,3} = 2m.$$

$$c(\lambda_{0,2m+1} \rightsquigarrow \lambda_{1,3}) = \prod_{k=1}^2 \frac{\Gamma(\lambda_{1,k} - \lambda_{1,3})}{\Gamma(\left| \left\{ \lambda_{0,2m+1} \quad \lambda_{1,k} \quad \lambda_{2,1} \right\} \right|)} \cdot \prod_{k=1}^{2m} \frac{\Gamma(\lambda_{0,2m+1} - \lambda_{0,k} + 1)}{\Gamma(\left| \left\{ \lambda_{0,k} \quad \lambda_{1,1} \quad \lambda_{2,1} \right\} \right|)},$$

$$c(\lambda_{1,3} \rightsquigarrow \lambda_{0,2m+1}) = \prod_{k=1}^2 \frac{\Gamma(\lambda_{1,3} - \lambda_{1,k} + 1)}{\Gamma\left(\left\{ \begin{array}{cc} [\lambda_{1,k}]_{(m)} & [\lambda_{2,1}]_{(m)} \\ (\lambda_{0,\nu})_{1 \leq \nu \leq 2m} & [\lambda_{1,3-k}]_{(m-1)} \\ & \lambda_{1,3} \end{array} \right\}\right)} \cdot \prod_{k=1}^{2m} \frac{\Gamma(\lambda_{0,k} - \lambda_{0,2m+1})}{\Gamma\left(\left\{ \begin{array}{cc} [\lambda_{1,1}]_{(m-1)} & [\lambda_{2,1}]_{(m)} \\ (\lambda_{0,\nu})_{1 \leq \nu \leq 2m} & [\lambda_{1,2}]_{(m-1)} \\ & [\lambda_{2,2}]_{(m-1)} \\ & \lambda_{1,3} \end{array} \right\}\right)}.$$

The condition for the irreducibility is

$$\begin{cases} \lambda_{0,\nu} + \lambda_{1,k} + \lambda_{2,1} \notin \mathbb{Z} & (1 \leq \nu \leq 2m + 1, k = 1, 2), \\ \lambda_{0,\nu} + \lambda_{0,\nu'} + \lambda_{1,1} + \lambda_{1,2} + \lambda_{2,1} + \lambda_{2,2} - 1 \notin \mathbb{Z} & (1 \leq \nu < \nu' \leq 2m + 1, k = 1, 2). \end{cases}$$

The same statement using the above linear functions as in the case of even family is valid for the bijectivity of the shift operator with respect to compatible shift  $(\epsilon_{j,\nu})$ .

We note that the operation  $\text{RAd}(\partial^{-\mu}) \circ \text{RAd}(x^{-\lambda_{1,2}}(1-x)^{-\lambda_{2,2}})$  transforms the operator and solutions with the above Riemann scheme of type  $EO_n$  into those of type  $EO_{n+1}$ :

$$\begin{aligned} & \left\{ \begin{array}{ccc} \lambda_{0,1} & [\lambda_{1,1}]_{(\lfloor \frac{n}{2} \rfloor)} & [\lambda_{2,1}]_{(\lfloor \frac{n+1}{2} \rfloor)} \\ \vdots & [\lambda_{1,2}]_{(\lfloor \frac{n-1}{2} \rfloor)} & [\lambda_{2,2}]_{(\lfloor \frac{n}{2} \rfloor)} \\ \lambda_{0,n} & \lambda_{1,3} & \end{array} \right\} \\ & \xrightarrow{x^{-\lambda_{1,2}}(1-x)^{-\lambda_{2,2}}} \left\{ \begin{array}{ccc} \lambda_{0,1} + \lambda_{1,2} + \lambda_{2,2} & [\lambda_{1,1} - \lambda_{1,2}]_{(\lfloor \frac{n}{2} \rfloor)} & [\lambda_{2,1} - \lambda_{2,2}]_{(\lfloor \frac{n+1}{2} \rfloor)} \\ \vdots & [0]_{(\lfloor \frac{n-1}{2} \rfloor)} & [0]_{(\lfloor \frac{n}{2} \rfloor)} \\ \lambda_{0,n} + \lambda_{1,2} + \lambda_{2,2} & \lambda_{1,3} - \lambda_{1,2} & \end{array} \right\} \\ & \xrightarrow{\partial^{-\mu}} \left\{ \begin{array}{ccc} \lambda_{0,1} + \lambda_{1,2} + \lambda_{2,2} - \mu & [\lambda_{1,1} - \lambda_{1,2} + \mu]_{(\lfloor \frac{n}{2} \rfloor)} & [\lambda_{2,1} - \lambda_{2,2} + \mu]_{(\lfloor \frac{n+1}{2} \rfloor)} \\ \vdots & [\mu]_{(\lfloor \frac{n+1}{2} \rfloor)} & [\mu]_{(\lfloor \frac{n+2}{2} \rfloor)} \\ \lambda_{0,n} + \lambda_{1,2} + \lambda_{2,2} - \mu & \lambda_{1,3} - \lambda_{1,2} + \mu & \\ & 1 - \mu & \end{array} \right\}. \end{aligned}$$

**15.6. Trigonometric identities.** The connection coefficients corresponding to the Riemann scheme of the hypergeometric family in §15.4 satisfy

$$\begin{aligned} & \sum_{\nu=1}^n c(1 : \lambda_{1,2} \rightsquigarrow 0 : \lambda_{0,\nu}) \cdot c(0 : \lambda_{1,\nu} \rightsquigarrow 1 : \lambda_{1,2}) = 1, \\ & \sum_{\nu=1}^n c(\infty : \lambda_{2,i} \rightsquigarrow 0 : \lambda_{0,\nu}) \cdot c(0 : \lambda_{0,\nu} \rightsquigarrow \infty : \lambda_{2,j}) = \delta_{ij}. \end{aligned}$$

These equations with Remark 14.8 iii) give the identities

$$\begin{aligned} & \sum_{k=1}^n \frac{\prod_{\nu \in \{1, \dots, n\}} \sin(x_k - y_\nu)}{\prod_{\nu \in \{1, \dots, n\} \setminus \{k\}} \sin(x_k - x_\nu)} = \sin\left(\sum_{\nu=1}^n x_\nu - \sum_{\nu=1}^n y_\nu\right), \\ & \sum_{k=1}^n \prod_{\nu \in \{1, \dots, n\} \setminus \{k\}} \frac{\sin(y_i - x_\nu)}{\sin(x_k - x_\nu)} \prod_{\nu \in \{1, \dots, n\} \setminus \{j\}} \frac{\sin(x_k - y_\nu)}{\sin(y_j - y_\nu)} = \delta_{ij} \quad (1 \leq i, j \leq n). \end{aligned}$$

We have the following identity from the connection coefficients of even/odd families.

$$\begin{aligned} & \sum_{k=1}^n \sin(x_k + s) \cdot \sin(x_k + t) \cdot \prod_{\nu \in \{1, \dots, n\} \setminus \{k\}} \frac{\sin(x_k + x_\nu + 2u)}{\sin(x_k - x_\nu)} \\ &= \begin{cases} \sin\left(nu + \sum_{\nu=1}^n x_\nu\right) \cdot \sin\left(s + t + (n-2)u + \sum_{\nu=1}^n x_\nu\right) & \text{if } n = 2m, \\ \sin\left(s + (n-1)u + \sum_{\nu=1}^n x_\nu\right) \cdot \sin\left(t + (n-1)u + \sum_{\nu=1}^n x_\nu\right) & \text{if } n = 2m + 1. \end{cases} \end{aligned}$$

The direct proof of these identities using residue calculus is given by [Oc]. It is interesting that similar identities of rational functions are given in [Gl, Appendix] which studies the systems of Schlesinger canonical form corresponding to Simpson's list (cf. §15.2).

### 15.7. Rigid examples of order at most 4.

#### 15.7.1. *order 1.* 1, 1, 1

$$u(x) = x^{\lambda_1}(1-x)^{\lambda_2} \quad \{-\lambda_1 - \lambda_2 \quad \lambda_1 \quad \lambda_2\}$$

#### 15.7.2. *order 2.* 11, 11, 11 : $H_2$ (Gauss) $[\Delta(\mathbf{m})] = 1^4$

$$u_{H_2} = \partial^{-\mu_1} u(x) \quad \left\{ \begin{array}{ccc} -\mu_1 + 1 & 0 & 0 \\ -\lambda_1 - \lambda_2 - \mu_1 & \lambda_1 + \mu_1 & \lambda_2 + \mu_1 \end{array} \right\}$$

#### 15.7.3. *order 3.* There are two types.

$$\underline{111, 21, 111} : H_3 \text{ } ({}_3F_2) \quad [\Delta(\mathbf{m})] = 1^9$$

$$\begin{aligned} & u_{H_3} = \partial^{-\mu_2} x^{\lambda_3} u_{H_2} \\ & \left\{ \begin{array}{ccc} 1 - \mu_2 & 0 & [0]_{(2)} \\ -\lambda_3 - \mu_1 - \mu_2 + 1 & \lambda_3 + \mu_2 & \\ -\lambda_1 - \lambda_2 - \lambda_3 - \mu_1 - \mu_2 & \lambda_1 + \lambda_3 + \mu_1 + \mu_2 & \lambda_2 + \mu_1 + \mu_2 \end{array} \right\} \end{aligned}$$

$$\underline{21, 21, 21, 21} : P_3 \text{ (Jordan-Pochhammer)} \quad [\Delta(\mathbf{m})] = 1^4 \cdot 2$$

$$\begin{aligned} & u_{P_3} = \partial^{-\mu} x^{\lambda_0}(1-x)^{\lambda_1}(c_2-x)^{\lambda_2} \\ & \left\{ \begin{array}{cccc} [1-\mu]_{(2)} & [0]_{(2)} & [0]_{(2)} & [0]_{(2)} \\ -\lambda_0 - \lambda_1 - \lambda_2 - \mu & \lambda_0 + \mu & \lambda_1 + \mu & \lambda_2 + \mu \end{array} \right\} \end{aligned}$$

#### 15.7.4. *order 4.* There are 6 types.

$$\underline{211, 211, 211} : \alpha_2 \quad [\Delta(\mathbf{m})] = 1^{10} \cdot 2$$

$$\begin{aligned} & \partial^{-\mu_2} x^{\lambda_3}(1-x)^{\lambda_4} u_{H_2} \\ & \left\{ \begin{array}{ccc} [-\mu_2 + 1]_{(2)} & [0]_{(2)} & [0]_{(2)} \\ -\mu_1 - \lambda_3 - \lambda_4 - \mu_2 + 1 & \lambda_3 + \mu_2 & \lambda_4 + \mu_2 \\ -\lambda_1 - \lambda_2 - \lambda_3 - \lambda_4 - \mu_1 - \mu_2 & \lambda_1 + \lambda_3 + \mu_1 + \mu_2 & \lambda_2 + \lambda_4 + \mu_1 + \mu_2 \end{array} \right\} \end{aligned}$$

$$\underline{1111, 31, 1111} : H_4 \text{ } ({}_4F_3) \quad [\Delta(\mathbf{m})] = 1^{16}$$

$$\begin{aligned} & \partial^{-\mu_3} x^{\lambda_4} u_{H_3} \\ & \left\{ \begin{array}{ccc} -\mu_3 + 1 & 0 & [0]_{(3)} \\ -\lambda_4 - \mu_2 - \mu_3 + 1 & \lambda_4 & \\ -\lambda_3 - \lambda_4 - \mu_1 - \mu_2 - \mu_3 + 1 & \lambda_3 + \lambda_4 + \mu_2 + \mu_3 & \\ -\lambda_1 - \dots - \lambda_4 - \mu_1 - \mu_2 - \mu_3 & \lambda_1 + \dots + \lambda_4 + \mu_1 + \mu_2 + \mu_3 & \lambda_2 + \mu_1 + \mu_2 + \mu_3 \end{array} \right\} \end{aligned}$$

$$\underline{211, 22, 1111} : EO_4 \quad [\Delta(\mathbf{m})] = 1^{14}$$

$$\partial^{-\mu_3}(1-x)^{-\lambda'} u_{H_3}, \quad \lambda' = \lambda_2 + \mu_1 + \mu_2$$

$$\left\{ \begin{array}{ccc} \lambda_2 + \mu_1 - \mu_2 - \mu_3 + 1 & [0]_{(2)} & [-\lambda_2 - \mu_1 - \mu_2 + \mu_3]_{(2)} \\ \lambda_2 - \lambda_3 - \mu_3 + 1 & \lambda_3 + \mu_2 + \mu_3 & \\ -\lambda_1 - \lambda_3 - \mu_3 & \lambda_1 + \lambda_3 + \mu_1 + \mu_2 + \mu_3 & [0]_{(2)} \\ -\mu_3 + 1 & & \end{array} \right\}$$

We have the integral representation of the local solution corresponding to the exponent at 0:

$$\int_0^x \int_0^t \int_0^s (1-t)^{-\lambda_2 - \mu_1 - \mu_2} (x-t)^{\mu_3 - 1} s^{\lambda_3} (t-s)^{\mu_2 - 1} u^{\lambda_1} (1-u)^{\lambda_2} (s-u)^{\mu - 1} du ds dt.$$

$$\underline{211, 22, 31, 31} : I_4 \quad [\Delta(\mathbf{m})] = 1^6 \cdot 2^2$$

$$\partial^{-\mu_2}(c_2 - x)^{\lambda_3} u_{H_2}$$

$$\left\{ \begin{array}{cccc} [-\mu_2 + 1]_{(2)} & [0]_{(3)} & [0]_{(3)} & [0]_{(2)} \\ -\lambda_3 - \mu_1 - \mu_2 + 1 & & & [\lambda_3 + \mu_2]_{(2)} \\ -\lambda_1 - \lambda_2 - \lambda_3 - \mu_1 - \mu_2 & \lambda_1 + \mu_1 + \mu_2 & \lambda_2 + \mu_1 + \mu_2 & \end{array} \right\}$$

$$\underline{31, 31, 31, 31, 31} : P_4 \quad [\Delta(\mathbf{m})] = 1^5 \cdot 3$$

$$u_{P_4} = \partial^{-\mu} x^{\lambda_0} (1-x)^{\lambda_1} (c_2 - x)^{\lambda_2} (c_3 - x)^{\lambda_3}$$

$$\left\{ \begin{array}{ccccc} [-\mu + 1]_{(3)} & [0]_{(3)} & [0]_{(3)} & [0]_{(3)} & [0]_{(3)} \\ -\lambda_0 - \lambda_2 - \lambda_3 - \mu & \lambda_0 + \mu & \lambda_1 + \mu & \lambda_2 + \mu & \lambda_3 + \mu \end{array} \right\}$$

$$\underline{22, 22, 22, 31} : P_{4,4} \quad [\Delta(\mathbf{m})] = 1^8 \cdot 2$$

$$\partial^{-\mu'} x^{-\lambda'_0} (1-x)^{-\lambda'_1} (c_2 - x)^{-\lambda'_2} u_{P_3}, \quad \lambda'_j = \lambda_j + \mu, \quad \mu' = \lambda_0 + \lambda_1 + \lambda_2 + 2\mu$$

$$\left\{ \begin{array}{cccc} [1 - \mu']_{(3)} & [\lambda_1 + \lambda_2 + \mu]_{(2)} & [\lambda_0 + \lambda_2 + \mu]_{(2)} & [\lambda_0 + \lambda_1 + \mu]_{(2)} \\ -\lambda_0 - \lambda_1 - \lambda_2 & [0]_{(2)} & [0]_{(2)} & [0]_{(2)} \end{array} \right\}$$

$$15.7.5. \text{ Tuple of partitions : } 211, 211, 211. \quad [\Delta(\mathbf{m})] = 1^{10} \cdot 2$$

$$211, 211, 211 = H_1 \oplus H_3 : 6 = H_2 \oplus H_2 : 4 = 2H_1 \oplus H_2 : 1$$

From the operations

$$\left\{ \begin{array}{ccc} x = \infty & 0 & 1 \\ 1 - \mu_1 & 0 & 0 \\ -\alpha_1 - \beta_1 - \mu_1 & \alpha_1 + \mu_1 & \beta_1 + \mu_1 \end{array} \right\}$$

$$\xrightarrow{x^{\alpha_2}(1-x)^{\beta_2}} \left\{ \begin{array}{ccc} x = \infty & 0 & 1 \\ 1 - \alpha_2 - \beta_2 - \mu_1 & \alpha_2 & \beta_2 \\ -\alpha_1 - \alpha_2 - \beta_1 - \beta_2 - \mu_1 & \alpha_1 + \alpha_2 + \mu_1 & \beta_1 + \beta_2 + \mu_1 \end{array} \right\}$$

$$\xrightarrow{\partial^{-\mu_2}} \left\{ \begin{array}{ccc} x = \infty & 0 & 1 \\ [-\mu_2 + 1]_{(2)} & [0]_{(2)} & [0]_{(2)} \\ 1 - \beta_2 - \mu_1 - \mu_2 & \alpha_2 + \mu_2 & \beta_2 + \mu_2 \\ -\alpha_1 - \beta_1 - \beta_2 - \mu_1 - \mu_2 & \alpha_1 + \mu_1 + \mu_2 & \beta_1 + \beta_2 + \mu_1 + \mu_2 \end{array} \right\}$$

$$\longrightarrow \left\{ \begin{array}{ccc} x = \infty & 0 & 1 \\ [\lambda_{2,1}]_{(2)} & [\lambda_{0,1}]_{(2)} & [\lambda_{1,1}]_{(2)} \\ \lambda_{2,2} & \lambda_{0,2} & \lambda_{1,2} \\ \lambda_{2,3} & \lambda_{0,3} & \lambda_{1,3} \end{array} \right\} \quad \text{with} \quad \sum_{j=0}^2 (2\lambda_{j,1} + \lambda_{j,2} + \lambda_{j,3}) = 3,$$

we have the integral representation of the solutions as in the case of other examples we have explained and so here we will not discuss them. The universal operator of type 11, 11, 11 is

$$Q = x^2(1-x)^2 \partial^2 - (ax + b)x(1-x)\partial + (cx^2 + dx + e).$$

Here we have

$$\begin{aligned}
b &= \lambda'_{0,1} + \lambda'_{0,2} - 1, & e &= \lambda'_{0,1}\lambda'_{0,2}, \\
-a - b &= \lambda'_{1,1} + \lambda'_{1,2} - 1, & c + d + e &= \lambda'_{1,1}\lambda'_{1,2}, \\
& & c &= \lambda'_{2,1}\lambda'_{2,2}, \\
\lambda'_{0,1} &= \alpha_2, & \lambda'_{0,2} &= \alpha_1 + \alpha_2 + \mu_1, \\
\lambda'_{1,1} &= \beta_2, & \lambda'_{1,2} &= \beta_1 + \beta_2 + \mu_2, \\
\lambda'_{2,1} &= 1 - \beta_2 - \mu_1 - \mu_2, & \lambda'_{2,2} &= -\alpha_1 - \beta_1 - \beta_2 - \mu_1 - \mu_2
\end{aligned}$$

corresponding to the above second Riemann scheme. The operator corresponding to the tuple 211, 211, 211 is

$$\begin{aligned}
P &= \text{RAd}(\partial^{-\mu_2})Q \\
&= \text{RAd}(\partial^{-\mu_2})\left((\vartheta - \lambda'_{0,1})(\vartheta - \lambda'_{0,2})\right. \\
&\quad \left.+ x(-2\vartheta^2 + (2\lambda'_{0,1} + 2\lambda'_{0,2} + \lambda'_{1,1} + \lambda'_{1,2} - 1)\vartheta + \lambda'_{1,1}\lambda'_{1,2} - \lambda'_{0,1}\lambda'_{0,2} - \lambda'_{2,1}\lambda'_{2,2})\right. \\
&\quad \left.+ x^2(\vartheta + \lambda'_{2,1})(\vartheta + \lambda'_{2,2})\right) \\
&= \partial^2(\vartheta - \lambda'_{0,1} - \mu_2)(\vartheta - \lambda'_{0,2} - \mu_2) \\
&\quad + \partial(\vartheta - \mu_2 + 1)(-2(\vartheta - \mu_2)^2 + (2\lambda'_{0,1} + 2\lambda'_{0,2} + \lambda'_{1,1} + \lambda'_{1,2} - 1)(\vartheta - \mu_2) \\
&\quad + \lambda'_{1,1}\lambda'_{1,2} - \lambda'_{0,1}\lambda'_{0,2} - \lambda'_{2,1}\lambda'_{2,2}) \\
&\quad + (\vartheta - \mu_2 + 1)(\vartheta - \mu_2 + 2)(\vartheta + \lambda'_{2,1} - \mu_2)(\vartheta + \lambda'_{2,2} - \mu_2).
\end{aligned}$$

The condition for the irreducibility:

$$\begin{cases}
\lambda_{0,1} + \lambda_{1,1} + \lambda_{2,1} \notin \mathbb{Z}, \\
\lambda_{0,\nu} + \lambda_{1,1} + \lambda_{2,1} \notin \mathbb{Z}, \lambda_{0,1} + \lambda_{1,\nu} + \lambda_{2,1} \notin \mathbb{Z}, \lambda_{0,1} + \lambda_{1,1} + \lambda_{2,\nu} \notin \mathbb{Z} \quad (\nu = 2, 3), \\
\lambda_{0,1} + \lambda_{0,2} + \lambda_{1,1} + \lambda_{1,\nu} + \lambda_{2,1} + \lambda_{2,\nu'} \notin \mathbb{Z} \quad (\nu, \nu' \in \{2, 3\}).
\end{cases}$$

There exist three types of direct decompositions of the tuple and there are 4 direct decompositions which give the connection coefficient  $c(\lambda_{0,3} \rightsquigarrow \lambda_{1,3})$  by the formula (14.10) in Theorem 14.6:

$$\begin{aligned}
21\bar{1}, 21\bar{1}, 211 &= 00\bar{1}, 100, 100 \oplus 210, 11\bar{1}, 111 \\
&= 11\bar{1}, 210, 111 \oplus 100, 00\bar{1}, 100 \\
&= 10\bar{1}, 110, 110 \oplus 110, 10\bar{1}, 101 \\
&= 10\bar{1}, 110, 101 \oplus 110, 10\bar{1}, 110
\end{aligned}$$

Thus we have

$$c(\lambda_{0,3} \rightsquigarrow \lambda_{1,3}) = \frac{\prod_{\nu=1}^2 \Gamma(\lambda_{0,3} - \lambda_{0,\nu} + 1)}{\Gamma(\lambda_{0,3} + \lambda_{1,1} + \lambda_{2,1}) \cdot \Gamma(1 - \lambda_{0,1} - \lambda_{1,3} - \lambda_{2,1})} \cdot \frac{\prod_{\nu=1}^2 \Gamma(\lambda_{1,\nu} - \Gamma_{1,3})}{\prod_{\nu=2}^3 \Gamma(\lambda_{0,1} + \lambda_{0,3} + \lambda_{1,1} + \lambda_{1,2} + \lambda_{2,1} + \lambda_{2,\nu} - 1)}.$$

We can also calculate generalized connection coefficient defined in Definition 14.17:

$$c([\lambda_{0,1}]_{(2)} \rightsquigarrow [\lambda_{1,1}]_{(2)}) = \frac{\prod_{\nu=2}^3 (\Gamma(\lambda_{0,1} - \lambda_{0,\nu} + 2) \cdot \Gamma(\lambda_{1,\nu} - \lambda_{1,1} - 1))}{\prod_{\nu=2}^3 (\Gamma(\lambda_{0,1} + \lambda_{1,\nu} + \lambda_{2,1}) \cdot \Gamma(1 - \lambda_{0,\nu} - \lambda_{1,1} - \lambda_{2,1}))}.$$

This can be proved by the procedure given in Remark 14.19 as in the case of the formula (15.32). Note that the gamma functions in the numerator of this formula



correspond to Remark 14.19 (2) and those in the denominator correspond to the rigid decompositions

$$\begin{aligned} \underline{2}11, \bar{2}11, 211 &= \underline{1}00, \bar{0}10, 100 \oplus \underline{1}11, \bar{2}01, 111 = \underline{1}00, \bar{0}01, 100 \oplus \underline{1}11, \bar{2}10, 111 \\ &= \underline{2}10, \bar{1}11, 111 \oplus \underline{0}01, \bar{1}00, 100 = \underline{2}01, \bar{1}11, 111 \oplus \underline{0}10, \bar{1}00, 100. \end{aligned}$$

The equation  $Pu = 0$  with the Riemann scheme  $\left\{ \begin{array}{ccc} x = \infty & 0 & 1 \\ [\lambda_{0,1}]_{(2)} & [0]_{(2)} & [0]_{(2)} \\ \lambda_{0,2} & \lambda_{1,2} & \lambda_{2,2} \\ \lambda_{0,3} & \lambda_{1,3} & \lambda_{2,3} \end{array} \right\}$  is isomorphic to the system

$$\begin{aligned} \tilde{u}' &= \frac{A}{x} \tilde{u} + \frac{B}{x-1} \tilde{u}, \quad \tilde{u} = \begin{pmatrix} u_1 \\ u_2 \\ u_3 \\ u_4 \end{pmatrix}, \quad u_1 = u, \\ A &= \begin{pmatrix} 0 & 0 & c_1 & 0 \\ 0 & 0 & 0 & c_1 \\ 0 & 0 & a_1 & b_1 - b_2 - c_2 \\ 0 & 0 & 0 & a_2 \end{pmatrix}, \\ B &= \begin{pmatrix} 0 & 0 & 0 & 0 \\ 0 & 0 & 0 & 0 \\ -a_1 - b_2 + c_1 & -b_1 + b_2 + c_2 & b_2 & 0 \\ -a_1 + a_2 + c_2 & -a_2 - b_1 + c_1 & a_1 - a_2 - c_2 & b_1 \end{pmatrix}, \\ &\begin{cases} a_1 = \lambda_{1,2}, \\ a_2 = \lambda_{1,3}, \\ b_1 = \lambda_{2,2} - 2, \\ b_2 = \lambda_{2,3} - 1, \\ c_1 = -\lambda_{0,1}, \\ c_2 = \lambda_{0,1} + \lambda_{0,2} + \lambda_{1,2} + \lambda_{2,2} - 1 \end{cases} \end{aligned}$$

when  $\lambda_{0,1}(\lambda_{0,1} + \lambda_{2,2})(\lambda_{0,1} + \lambda_{0,2} + \lambda_{1,2} + \lambda_{2,3} - 2) \neq 0$ . Let  $u(x)$  be a holomorphic solution of  $Pu = 0$  in a neighborhood of  $x = 0$ . By a direct calculation we have

$$\begin{aligned} u_1(0) &= \frac{(a_1 - 1)(a_2 - 1)}{(b_1 - c_1 + 1)(b_1 - b_2 - c_2)c_1} u'(0) + \\ &\frac{(a_2 + b_2 + c_2 - 1)a_1 - (c_1 + c_2)a_2 + (a_2 - a_1 + c_2)b_1 - (c_2 + 1)b_2 - c_2^2 + c_1}{(b_1 - c_1 + 1)(b_1 - b_2 - c_2)} u(0). \end{aligned}$$

Since the shift described in Remark 14.19 (1) corresponds to the shift

$$(a_1, a_2, b_1, b_2, c_1, c_2) \mapsto (a_1 - k, a_2 - k, b_1 + k, b_2 + k, c_1, c_2),$$

it follows from Theorem 14.10 that

$$\lim_{k \rightarrow \infty} c([\lambda_{0,1}]_{(2)} \rightsquigarrow [\lambda_{1,1}]_{(2)}) \Big|_{\substack{\lambda_{0,2} \mapsto \lambda_{0,2} - k, \lambda_{0,3} \mapsto \lambda_{0,3} - k \\ \lambda_{1,2} \mapsto \lambda_{1,2} + k, \lambda_{1,3} \mapsto \lambda_{1,3} + k}} = 1$$

as in the proof of (15.32) because  $u_1(0) \sim \frac{k}{(b_1 - b_2 - c_2)c_1} u'(0) + Cu(0)$  with  $C \in \mathbb{C}$  when  $k \rightarrow \infty$ . Thus we can calculate this generalized connection coefficient by the procedure described in Remark 14.19.

Using (4.8), we have the series expansion of the local solution at  $x = 0$  corresponding to the exponent  $\alpha_1 + \mu_1 + \mu_2$  for the Riemann scheme parametrized by  $\alpha_i, \beta_i$  and  $\mu_i$  with  $i = 1, 2$ .

$$I_0^{\mu_2} x^{\alpha_2} (1-x)^{\beta_2} I_0^{\mu_1} x^{\alpha_1} (1-x)^{\beta_1}$$

$$\begin{aligned}
&= I_0^{\mu_2} \frac{\Gamma(\alpha_1 + 1)}{\Gamma(\alpha_1 + \mu_1 + 1)} \sum_{n=0}^{\infty} \frac{(\alpha_1 + 1)_n (-\beta_1)_n}{(\alpha_1 + \mu_1 + 1)_n n!} x^{\alpha_2} (1-x)^{\beta_2} x^{\alpha_1 + \mu_1 + n} \\
&= \frac{\Gamma(\alpha_1 + 1) \Gamma(\alpha_1 + \alpha_2 + \mu_1 + 1) x^{\alpha_1 + \alpha_2 + \mu_1 + \mu_2}}{\Gamma(\alpha_1 + \mu_1 + 1) \Gamma(\alpha_1 + \alpha_2 + \mu_1 + \mu_2 + 1)} \\
&\quad \cdot \sum_{m, n=0}^{\infty} \frac{(\alpha_1 + 1)_n (\alpha_1 + \alpha_2 + \mu_1 + 1)_{m+n} (-\beta_1)_n (-\beta_2)_m}{(\alpha_1 + \mu_1 + 1)_n (\alpha_1 + \alpha_2 + \mu_1 + \mu_2 + 1)_{m+n} n! m!} x^{m+n} \\
&= \frac{\Gamma(\alpha_1 + 1) \Gamma(\alpha_1 + \alpha_2 + \mu_1 + 1) x^{\alpha_1 + \alpha_2 + \mu_1 + \mu_2} (1-x)^{-\beta_2}}{\Gamma(\alpha_1 + \mu_1 + 1) \Gamma(\alpha_1 + \alpha_2 + \mu_1 + \mu_2 + 1)} \\
&\quad \cdot \sum_{m, n=0}^{\infty} \frac{(\alpha_1 + 1)_n (\alpha_1 + \alpha_2 + \mu_1 + 1)_n (\mu_2)_m (-\beta_1)_n (-\beta_2)_m}{(\alpha_1 + \mu_1 + 1)_n (\alpha_1 + \alpha_2 + \mu_1 + \mu_2 + 1)_{m+n} m! n!} x^n \left(\frac{x}{x-1}\right)^m.
\end{aligned}$$

Note that when  $\beta_2 = 0$ , the local solution is reduced to a local solution of the equation at  $x = 0$  satisfied by the hypergeometric series  ${}_3F_2(\alpha'_1, \alpha'_2, \alpha'_3; \beta'_1, \beta'_2; x)$  and when  $\alpha_2 = 0$ , it is reduced to a local solution of the equation corresponding to the exponent at  $x = 1$  with free multiplicity.

Let  $u_0(\alpha_1, \alpha_2, \beta_1, \beta_2, \mu_1, \mu_2; x)$  be the local solution normalized by

$$u_0(\alpha, \beta, \mu; x) - x^{\alpha_1 + \alpha_2 + \mu_1 + \mu_2} \in x^{\alpha_1 + \alpha_2 + \mu_1 + \mu_2 + 1} \mathcal{O}_0$$

for generic  $\alpha, \beta, \mu$ . Then we have the recurrence relation

$$\begin{aligned}
u_0(\alpha, \beta_1 - 1, \beta_2, \mu; x) &= u_0(\alpha, \beta, \mu; x) + \frac{(\alpha_1 + 1)(\alpha_1 + \alpha_2 + \mu_1 + 1)}{(\alpha_1 + \mu_1 + 1)(\alpha_1 + \alpha_2 + \mu_1 + \mu_2 + 1)} \\
&\quad \cdot u_0(\alpha_1 + 1, \alpha_2, \beta_1 - 1, \beta_2, \mu; x).
\end{aligned}$$

15.7.6. *Tuple of partitions* : 211, 22, 31, 31.  $[\Delta(\mathbf{m})] = 1^6 \cdot 2$

$$\begin{aligned}
211, 22, 31, 31 &= H_1 \oplus P_3 : 4 = H_2 \oplus H_2 : 2 = 2H_1 \oplus H_2 : 2 \\
&= 010, 10, 10, 10 \oplus 201, 12, 21, 21 = 010, 01, 10, 10 \oplus 201, 21, 21, 21 \\
&= 001, 10, 10, 10 \oplus 210, 12, 21, 21 = 001, 01, 10, 10 \oplus 210, 21, 21, 21 \\
&= 110, 11, 11, 20 \oplus 101, 11, 20, 11 = 110, 11, 20, 11 \oplus 101, 11, 11, 20 \\
&= 200, 20, 20, 20 \oplus 011, 02, 11, 11 \\
&\xrightarrow{\partial_{max}} 011, 02, 11, 11
\end{aligned}$$

$$\begin{aligned}
&\left\{ \begin{array}{cccc} x=0 & \frac{1}{c_1} & \frac{1}{c_2} & \infty \\ [\lambda_{0,1}]_{(3)} & [\lambda_{1,1}]_{(3)} & [\lambda_{2,1}]_{(2)} & [\lambda_{3,1}]_{(2)} \\ \lambda_{0,2} & \lambda_{1,2} & \lambda_{2,2} & [\lambda_{3,2}]_{(2)} \\ & & \lambda_{2,3} & \end{array} \right\} \\
&\xrightarrow{x^{-\lambda_{0,1}}(1-c_1x)^{-\lambda_{1,1}}(1-c_2x)^{-\lambda_{2,1}}} \\
&\left\{ \begin{array}{cccc} x=0 & \frac{1}{c_1} & \frac{1}{c_2} & \infty \\ [0]_{(3)} & [0]_{(3)} & [0]_{(2)} & [\lambda_{3,1} + \lambda_{0,1} + \lambda_{1,1} + \lambda_{2,1}]_{(2)} \\ \lambda_{0,2} - \lambda_{0,1} & \lambda_{1,2} - \lambda_{1,1} & \lambda_{2,2} - \lambda_{2,1} & [\lambda_{3,2} + \lambda_{0,1} + \lambda_{1,1} + \lambda_{2,1}]_{(2)} \\ & & \lambda_{2,3} - \lambda_{2,1} & \end{array} \right\} \\
&\xrightarrow{\partial^{-\lambda'_1}} \\
&\left\{ \begin{array}{cccc} x=0 & \frac{1}{c_1} & \frac{1}{c_2} & \infty \\ 0 & 0 & 0 & \\ \lambda_{0,2} + \lambda'_1 - \lambda_{0,1} & \lambda_{1,2} + \lambda'_1 - \lambda_{1,1} & \lambda_{2,2} + \lambda'_1 - \lambda_{2,1} & [\lambda_{3,2} - \lambda_{3,1} + 1]_{(2)} \\ & & \lambda_{2,3} + \lambda'_1 - \lambda_{2,1} & \end{array} \right\}
\end{aligned}$$

The condition for the irreducibility:

$$\begin{cases} \lambda_{0,1} + \lambda_{1,1} + \lambda_{2,\nu} + \lambda_{3,\nu'} \notin \mathbb{Z} \quad (\nu \in \{1, 2, 3\}, \nu' \in \{1, 2\}), \\ \lambda_{0,1} + \lambda_{0,2} + 2\lambda_{1,1} + \lambda_{2,1} + \lambda_{2,\nu} + \lambda_{3,1} + \lambda_{3,2} \notin \mathbb{Z} \quad (\nu \in \{2, 3\}), \end{cases}$$

$$c(\lambda_{0,2} \rightsquigarrow \lambda_{1,2}) = \frac{\Gamma(\lambda_{0,2} - \lambda_{0,1} + 1)\Gamma(\lambda_{1,2} - \lambda_{1,1})(1 - \frac{c_2}{c_1})^{\lambda_{2,1}}}{\prod_{\nu=2}^3 \Gamma(\lambda_{0,1} + \lambda_{0,2} + 2\lambda_{1,1} + \lambda_{2,1} + \lambda_{2,\nu} + \lambda_{3,1} + \lambda_{3,2} - 1)},$$

$$c(\lambda_{0,2} \rightsquigarrow \lambda_{2,3}) = \prod_{\nu=1}^2 \frac{\Gamma(\lambda_{2,3} - \lambda_{2,\nu})}{\Gamma(1 - \lambda_{0,1} - \lambda_{1,1} - \lambda_{2,3} - \lambda_{3,\nu})} \cdot \frac{\Gamma(\lambda_{0,2} - \lambda_{0,1} + 1)(1 - \frac{c_1}{c_2})^{\lambda_{1,1}}}{\Gamma(\lambda_{0,1} + \lambda_{0,2} + 2\lambda_{1,1} + \lambda_{2,1} + \lambda_{2,2} + \lambda_{3,1} + \lambda_{3,2} - 1)}.$$

15.7.7. *Tuple of partitions* : 22, 22, 22, 31.  $[\Delta(\mathbf{m})] = 1^8 \cdot 2$

$$\begin{aligned} 22, 22, 22, 31 &= H_1 \oplus P_3 : 8 = 2(11, 11, 11, 20) \oplus 00, 00, 00, (-1)1 \\ &= 10, 10, 10, 10 \oplus 12, 12, 12, 21 = 10, 10, 01, 10 \oplus 12, 12, 21, 21 \\ &= 10, 01, 10, 10 \oplus 12, 21, 12, 21 = 10, 01, 01, 10 \oplus 12, 21, 21, 21 \\ &= 01, 10, 10, 10 \oplus 21, 12, 12, 21 = 01, 10, 01, 10 \oplus 21, 12, 21, 21 \\ &= 01, 01, 10, 10 \oplus 21, 21, 12, 21 = 01, 01, 01, 10 \oplus 21, 21, 21, 21 \\ &\xrightarrow{2} 12, 12, 12, 21 \end{aligned}$$

The condition for the irreducibility:

$$\begin{cases} \lambda_{0,i} + \lambda_{1,j} + \lambda_{2,k} + \lambda_{3,1} \notin \mathbb{Z} \quad (i, j, k \in \{1, 2\}), \\ \lambda_{0,1} + \lambda_{0,2} + \lambda_{1,1} + \lambda_{1,2} + \lambda_{2,1} + \lambda_{2,2} + \lambda_{3,1} + \lambda_{3,2} \notin \mathbb{Z}. \end{cases}$$

15.8. **Other rigid examples with a small order.** First we give an example which is not of Okubo type.

15.8.1. 221, 221, 221. The Riemann Scheme and the direct decompositions are

$$\left\{ \begin{array}{ccc} x=0 & 1 & \infty \\ [\lambda_{0,1}]_{(2)} & [\lambda_{1,1}]_{(2)} & [\lambda_{2,1}]_{(2)} \\ [\lambda_{0,2}]_{(2)} & [\lambda_{1,2}]_{(2)} & [\lambda_{2,2}]_{(2)} \\ \lambda_{0,3} & \lambda_{1,3} & \lambda_{2,3} \end{array} \right\}, \quad \sum_{j=0}^2 (2\lambda_{j,1} + 2\lambda_{j,2} + \lambda_{j,3}) = 4,$$

$$[\Delta(\mathbf{m})] = 1^{14} \cdot 2$$

$$\begin{aligned} 22\bar{1}, 22\bar{1}, 22\bar{1} &= H_1 \oplus 21\bar{1}, 21\bar{1}, 21\bar{1} : 8 & 6 &= |2, 2, 2| \\ &= H_2 \oplus H_3 : 6 & 11 &= |21, 22, 22| \\ &= 2H_2 \oplus H_1 : 1 \\ &= 10\bar{1}, 110, 110 \oplus 120, 11\bar{1}, 111 = 01\bar{1}, 110, 110 \oplus 210, 11\bar{1}, 111 \\ &= 11\bar{1}, 120, 111 \oplus 110, 10\bar{1}, 110 = 11\bar{1}, 210, 111 \oplus 110, 01\bar{1}, 110 \\ &\rightarrow 121, 121, 121 \end{aligned}$$

and a connection coefficient is give by

$$c(\lambda_{0,3} \rightsquigarrow \lambda_{1,3}) = \prod_{\nu=1}^2 \left( \frac{\Gamma(\lambda_{0,3} - \lambda_{0,\nu} + 1)}{\Gamma(\lambda_{0,\nu} + \lambda_{0,3} + \lambda_{1,1} + \lambda_{1,2} + \lambda_{2,1} + \lambda_{2,2} - 1)} \cdot \frac{\Gamma(\lambda_{1,\nu} - \lambda_{1,3})}{\Gamma(2 - \lambda_{0,1} - \lambda_{0,2} - \lambda_{1,\nu} - \lambda_{1,3} - \lambda_{2,1} - \lambda_{2,2})} \right).$$

Using this example we explain an idea to get all the rigid decompositions  $\mathbf{m} = \mathbf{m}' \oplus \mathbf{m}''$ . Here we note that  $\text{idx}(\mathbf{m}, \mathbf{m}') = 1$ . Put  $\mathbf{m} = 221, 221, 221$ . We may assume  $\text{ord } \mathbf{m}' \leq \text{ord } \mathbf{m}''$ .

Suppose  $\text{ord } \mathbf{m}' = 1$ . Then  $\mathbf{m}'$  is isomorphic to 1, 1, 1 and there exists tuples of indices  $(\ell_0, \ell_1, \ell_2)$  such that  $m'_{j,\nu} = \delta_{j,\ell_j}$ . Then  $\text{idx}(\mathbf{m}, \mathbf{m}') = m_{0,\ell_0} + m_{1,\ell_1} + m_{1,\ell_2} - (3 - 2) \text{ord } \mathbf{m} \cdot \text{ord } \mathbf{m}'$  and we have  $m_{0,\ell_0} + m_{1,\ell_1} + m_{1,\ell_2} = 6$ . Hence  $(m_{0,\ell_0}, m_{1,\ell_1}, m_{1,\ell_2}) = (2, 2, 2)$ , which is expressed by  $6 = |2, 2, 2|$  in the above. Since  $\ell_j = 1$  or  $2$  for  $0 \leq j \leq 2$ , it is clear that there exist 8 rigid decompositions with  $\text{ord } \mathbf{m}' = 1$ .

Suppose  $\text{ord } \mathbf{m}' = 2$ . Then  $\mathbf{m}'$  is isomorphic to 11, 11, 11 and there exists tuples of indices  $(\ell_{0,1}, \ell_{0,2}, \ell_{1,1}, \ell_{1,2}, \ell_{2,1}, \ell_{2,2})$  which satisfies  $\sum_{j=0}^2 \sum_{\nu=1}^2 m_{j,\ell_\nu} = (3 - 2) \text{ord } \mathbf{m} \cdot \text{ord } \mathbf{m}' + 1 = 11$ . Hence we may assume  $(\ell_{0,1}, \ell_{0,2}, \ell_{1,1}, \ell_{1,2}, \ell_{2,1}, \ell_{2,2}) = (2, 1, 2, 2, 2, 2)$  modulo obvious symmetries, which is expressed by  $11 = |21, 22, 22|$ . There exist 6 rigid decompositions with  $\text{ord } \mathbf{m}' = 2$ .

In general this method to get all the rigid decompositions of  $\mathbf{m}$  is useful when  $\text{ord } \mathbf{m}$  is not big. For example if  $\text{ord } \mathbf{m} \leq 7$ ,  $\mathbf{m}'$  is isomorphic to 1, 1, 1 or 11, 11, 11 or 21, 111, 111.

The condition for the irreducibility is given by Theorem 12.10 and it is

$$\begin{cases} \lambda_{0,i} + \lambda_{1,j} + \lambda_{2,k} \notin \mathbb{Z} & (i, j, k \in \{1, 2\}), \\ \sum_{j=0}^2 \sum_{\nu=1}^2 \lambda_{j,\nu} + (\lambda_{i,3} - \lambda_{i,k}) \notin \mathbb{Z} & (i \in \{0, 1, 2\}, k \in \{1, 2\}). \end{cases}$$

15.8.2. *Other examples.* Theorem 14.6 shows that the connection coefficients between local solutions of rigid differential equations which correspond to the eigenvalues of local monodromies with free multiplicities are given by direct decompositions of the tuples of partitions  $\mathbf{m}$  describing their spectral types.

We list the rigid decompositions  $\mathbf{m} = \mathbf{m}' \oplus \mathbf{m}''$  of rigid indivisible  $\mathbf{m}$  in  $\mathcal{P}^{(5)} \cup \mathcal{P}_3^{(6)}$  satisfying  $m_{0,n_0} = m_{1,n_1} = m'_{0,n_0} = m''_{1,n_1} = 1$ . The positions of  $m_{0,n_0}$  and  $m_{1,n_1}$  in  $\mathbf{m}$  to which Theorem 14.6 applies are indicated by an overline and an underline, respectively. The number of decompositions in each case equals  $n_0 + n_1 - 2$  and therefore the validity of the following list is easily verified.

We show the tuple  $\partial_{\max} \mathbf{m}$  after  $\rightarrow$ . The type  $[\Delta(\mathbf{m})]$  of  $\Delta(\mathbf{m})$  is calculated by (9.42), which is also indicated in the following with this calculation. For example, when  $\mathbf{m} = 311, 221, 2111$ , we have  $d(\mathbf{m}) = 2$ ,  $\mathbf{m}' = \partial \mathbf{m} = 111, 021, 0111$ ,  $[\Delta(s(111, 021, 0111))] = 1^9$ ,  $\{m'_{j,\nu} - m'_{j,1} \in \mathbb{Z}_{>0}\} \cup \{2\} = \{1, 1, 1, 1, 2, 2\}$  and hence  $[\Delta(\mathbf{m})] = 1^9 \times 1^4 \cdot 2^2 = 1^{13} \cdot 2^2$ , which is a partition of  $h(\mathbf{m}) - 1 = 17$ . Here we note that  $h(\mathbf{m})$  is the sum of the numbers attached the Dynkin diagram



All the decompositions of the tuple  $\mathbf{m}$  corresponding to the elements in  $\Delta(\mathbf{m})$  are given, by which we easily get the necessary and sufficient condition for the irreducibility (cf. Theorem 12.13 and §15.9.2).

$$\text{ord } \mathbf{m} = 5$$

$$\begin{aligned} 311, 221, 2111 &= 100, 010, 0001 \oplus 211, 211, 2110 & 6 &= |3, 2, 1| \\ &= 100, 001, 1000 \oplus 211, 220, 1111 & 6 &= |3, 1, 2| \\ &= 101, 110, 1001 \oplus 210, 111, 1110 & 11 &= |31, 22, 21| \\ &= 2(100, 100, 1000) \oplus 111, 021, 0111 \\ &\xrightarrow{2} 111, 021, 0111 \end{aligned}$$

$$[\Delta(\mathbf{m})] = 1^9 \times 1^4 \cdot 2^2 = 1^{13} \cdot 2^2$$

$$\begin{aligned} \mathbf{m} &= H_1 \oplus 211, 211, 211 : 6 = H_1 \oplus EO_4 : 1 = H_2 \oplus H_3 : 6 = 2H_1 \oplus H_3 : 2 \\ 31\bar{1}, 22\bar{1}, 211\bar{1} &= 211, 211, 2110 \oplus 100, 010, 0001 = 211, 121, 2110 \oplus 100, 100, 0001 \\ &= 100, 001, 1000 \oplus 211, 220, 1111 \\ &= 210, 111, 1110 \oplus 101, 110, 1001 = 201, 111, 1110 \oplus 110, 110, 1001 \\ 31\bar{1}, 22\bar{1}, 211\bar{1} &= 211, 211, 2110 \oplus 100, 010, 0001 = 211, 121, 2110 \oplus 100, 100, 0001 \\ &= 201, 111, 1110 \oplus 110, 110, 1001 \\ &= 101, 110, 1010 \oplus 210, 111, 1101 = 101, 110, 1100 \oplus 210, 111, 1011 \\ 32, 211\bar{1}, 211\bar{1} &= 22, 1111, 2110 \oplus 10, 1000, 0001 = 10, 0001, 1000 \oplus 22, 2110, 1111 \\ &= 11, 1001, 1010 \oplus 21, 1110, 1101 = 11, 1001, 1100 \oplus 21, 1110, 1011 \\ &= 21, 1101, 1110 \oplus 11, 1010, 1001 = 21, 1011, 1110 \oplus 11, 1100, 1001 \\ &\xrightarrow{2} 12, 0111, 0111 \end{aligned}$$

$$[\Delta(\mathbf{m})] = 1^9 \times 1^7 \cdot 2 = 1^{16} \cdot 2$$

$$\begin{aligned} \mathbf{m} &= H_1 \oplus H_4 : 1 = H_1 \oplus EO_4 : 6 = H_2 \oplus H_3 : 9 = 2H_1 \oplus H_3 : 1 \\ 22\bar{1}, 22\bar{1}, 41, 41 &= 001, 100, 10, 10 \oplus 220, 121, 31, 31 = 001, 010, 10, 10 \oplus 220, 211, 31, 31 \\ &= 211, 220, 31, 31 \oplus 010, 001, 10, 10 = 121, 220, 31, 31 \oplus 100, 001, 10, 10 \\ &\xrightarrow{2} 021, 021, 21, 21 \end{aligned}$$

$$[\Delta(\mathbf{m})] = 1^4 \cdot 2 \times 1^4 \cdot 2^3 = 1^6 \cdot 2^4$$

$$\begin{aligned} \mathbf{m} &= H_1 \oplus 22, 211, 31, 31 : 4 = H_2 \oplus H_3 : 2 = 2H_1 \oplus P_3 : 4 \\ 22\bar{1}, 22\bar{1}, 41, 41 &= 001, 100, 10, 10 \oplus 220, 121, 31, 31 = 001, 010, 10, 10 \oplus 220, 211, 31, 31 \\ &= 111, 111, 30, 21 \oplus 110, 110, 11, 20 \end{aligned}$$

$$\begin{aligned} 22\bar{1}, 32, 32, 41 &= 101, 11, 11, 20 \oplus 120, 21, 21, 21 = 011, 11, 11, 20 \oplus 210, 21, 21, 21 \\ &= 001, 10, 10, 10 \oplus 220, 22, 22, 31 \\ &\xrightarrow{2} 021, 12, 12, 21 \end{aligned}$$

$$[\Delta(\mathbf{m})] = 1^4 \cdot 2 \times 1^3 \cdot 2^2 = 1^7 \cdot 2$$

$$\begin{aligned} \mathbf{m} &= H_1 \oplus 22, 22, 22, 31 : 1 = H_1 \oplus 211, 22, 31, 31 : 4 = H_2 \oplus P_3 : 2 \\ &= 2H_1 \oplus P_3 : 2 \end{aligned}$$

$$\begin{aligned} 31\bar{1}, 31\bar{1}, 32, 41 &= 001, 100, 10, 10 \oplus 310, 211, 22, 31 = 211, 301, 22, 31 \oplus 100, 001, 10, 10 \\ &= 101, 110, 11, 20 \oplus 210, 201, 21, 21 = 201, 210, 21, 21 \oplus 110, 101, 11, 20 \\ &\xrightarrow{3} 011, 011, 02, 11 \end{aligned}$$

$$[\Delta(\mathbf{m})] = 1^4 \times 1^4 \cdot 2 \cdot 3 = 1^8 \cdot 2 \cdot 3$$

$$\begin{aligned} \mathbf{m} &= H_1 \oplus 211, 31, 22, 31 : 4 = H_2 \oplus P_3 : 4 \\ &= 2H_1 \oplus H_3 : 1 = 3H_1 \oplus H_2 : 1 \\ 31\bar{1}, 31\bar{1}, 32, 41 &= 001, 100, 10, 10 \oplus 301, 211, 22, 31 \\ &= 101, 110, 11, 20 \oplus 210, 201, 21, 21 = 101, 101, 11, 20 \oplus 210, 210, 21, 21 \end{aligned}$$

$$\begin{aligned}
32, 32, 4\bar{1}, 4\bar{1}, 4\bar{1} &= 11, 11, 11, 20, 20 \oplus 21, 21, 30, 21, 21 \\
&= 21, 21, 21, 30, 21 \oplus 11, 11, 20, 11, 20 \\
&\xrightarrow{3} 02, 02, 11, 11, 11
\end{aligned}$$

$$[\Delta(\mathbf{m})] = 1^4 \times 2^2 \cdot 3 = 1^4 \cdot 2^2 \cdot 3$$

$$\mathbf{m} = H_1 \oplus P_4 : 1 = H_2 \oplus P_3 : 3 = 2H_1 \oplus P_3 : 2 = 3H_1 \oplus H_2 : 1$$

ord  $\mathbf{m} = 6$  and  $\mathbf{m} \in \mathcal{P}_3$

$$\begin{aligned}
32\bar{1}, 311\bar{1}, 222 &= 311, 2111, 221 \oplus 010, 1000, 001 & 7 &= |2, 3, 2| \\
&= 211, 2110, 211 \oplus 110, 1001, 011 & 13 &= |32, 31, 22| \\
&= 210, 1110, 111 \oplus 111, 2001, 111 \\
&\xrightarrow{2} 121, 1111, 022 \rightarrow 111, 0111, 012
\end{aligned}$$

$$[\Delta(\mathbf{m})] = 1^{14} \times 1 \cdot 2^3 = 1^{15} \cdot 2^3$$

$$\begin{aligned}
\mathbf{m} &= H_1 \oplus 311, 2111, 221 : 3 = H_2 \oplus 211, 211, 211 : 6 = H_3 \oplus H_3 : 6 \\
&= 2H_1 \oplus EO_4 : 3
\end{aligned}$$

$$\begin{aligned}
32\bar{1}, 311\bar{1}, 222 &= 211, 2110, 211 \oplus 110, 1001, 011 = 211, 2110, 121 \oplus 110, 1001, 101 \\
&= 211, 2110, 112 \oplus 110, 1001, 110 \\
&= 111, 2100, 111 \oplus 210, 1011, 111 = 111, 2010, 111 \oplus 210, 1101, 111
\end{aligned}$$

$$\begin{aligned}
32\bar{1}, 311\bar{1}, 311\bar{1} &= 221, 2111, 3110 \oplus 100, 1000, 0001 = 100, 0001, 1000 \oplus 221, 3110, 2111 \\
&= 211, 2101, 2110 \oplus 110, 1010, 1001 = 211, 2011, 2110 \oplus 110, 1101, 1001 \\
&= 110, 1001, 1100 \oplus 211, 2110, 2011 = 110, 1001, 1010 \oplus 211, 2110, 2101 \\
&\xrightarrow{3} 021, 0111, 0111
\end{aligned}$$

$$[\Delta(\mathbf{m})] = 1^9 \times 1^7 \cdot 2 \cdot 3 = 1^{16} \cdot 2 \cdot 3$$

$$\begin{aligned}
\mathbf{m} &= H_1 \oplus 221, 2111, 311 : 6 = H_1 \oplus 32, 2111, 2111 : 1 \\
&= H_2 \oplus 211, 211, 211 : 9 = 2H_1 \oplus H_4 : 1 = 3H_1 \oplus H_3 : 1
\end{aligned}$$

$$\begin{aligned}
32\bar{1}, 311\bar{1}, 311\bar{1} &= 221, 3110, 2111 \oplus 100, 0001, 1000 = 001, 1000, 1000 \oplus 320, 2111, 2111 \\
&= 211, 2110, 2110 \oplus 110, 1001, 1001 = 211, 2110, 2011 \oplus 110, 1001, 1100 \\
&= 211, 2110, 2011 \oplus 110, 1001, 1100
\end{aligned}$$

$$\begin{aligned}
32\bar{1}, 32\bar{1}, 221\bar{1} &= 211, 220, 1111 \oplus 110, 101, 1100 = 101, 110, 1100 \oplus 220, 211, 1111 \\
&= 111, 210, 1110 \oplus 210, 111, 1101 = 111, 210, 1101 \oplus 210, 111, 1110 \\
&\xrightarrow{2} 121, 121, 0211 \rightarrow 101, 101, 0011
\end{aligned}$$

$$[\Delta(\mathbf{m})] = 1^{10} \cdot 2 \times 1^4 \cdot 2^2 = 1^{14} \cdot 2^3$$

$$\begin{aligned}
\mathbf{m} &= H_1 \oplus 311, 221, 2111 : 4 = H_1 \oplus 221, 221, 221 : 2 \\
&= H_2 \oplus EO_4 : 2 = H_2 \oplus 211, 211, 211 : 4 = H_3 \oplus H_3 : 2 \\
&= 2H_1 \oplus 211, 211, 211 : 2 = 2(110, 110, 1100) \oplus 101, 101, 0011 : 1
\end{aligned}$$

$$\begin{aligned}
32\bar{1}, 32\bar{1}, 221\bar{1} &= 221, 221, 2210 \oplus 100, 100, 0001 = 110, 101, 1100 \oplus 211, 220, 1111 \\
&= 211, 211, 2110 \oplus 110, 110, 0101 = 211, 211, 1210 \oplus 110, 110, 1001 \\
&= 210, 111, 1110 \oplus 111, 210, 1101
\end{aligned}$$

$$\begin{aligned}
41\bar{1}, 221\bar{1}, 2211 &= 311, 2210, 2111 \oplus 100, 0001, 0100 = 311, 2210, 1211 \oplus 100, 0001, 1000 \\
&= 101, 1100, 1100 \oplus 310, 1111, 1111 = 201, 1110, 1110 \oplus 210, 1101, 1101 \\
&= 201, 1110, 1101 \oplus 210, 1101, 1110 \\
&\xrightarrow{2} 211, 0211, 0211 \rightarrow 011, 001, 0011
\end{aligned}$$

$$[\Delta(\mathbf{m})] = 1^{10} \cdot 2 \times 1^4 \cdot 2^3 = 1^{14} \cdot 2^4$$

$$\begin{aligned}
\mathbf{m} &= H_1 \oplus 311, 221, 2211 : 8 = H_2 \oplus H_4 : 2 = H_3 \oplus H_3 : 4 \\
&= 2H_1 \oplus 211, 211, 211 : 4
\end{aligned}$$

$$\begin{aligned}
411, 221\bar{1}, 2211 &= 311, 2111, 2210 \oplus 100, 0100, 0001 = 311, 1211, 2210 \oplus 100, 1000, 0001 \\
&= 100, 0001, 0100 \oplus 311, 2210, 2111 = 100, 0001, 1000 \oplus 311, 2210, 1211 \\
&= 201, 1101, 1110 \oplus 210, 1110, 1101 = 210, 1101, 1110 \oplus 201, 1110, 1101
\end{aligned}$$

$$\begin{aligned}
41\bar{1}, 222, 2111\bar{1} &= 311, 221, 21110 \oplus 100, 001, 00001 = 311, 212, 21110 \oplus 100, 010, 00001 \\
&= 311, 122, 21110 \oplus 100, 100, 00001 = 201, 111, 11100 \oplus 210, 111, 10011 \\
&= 201, 111, 11010 \oplus 210, 111, 10101 = 201, 111, 10110 \oplus 210, 111, 11001 \\
&\xrightarrow{2} 211, 022, 01111 \rightarrow 111, 012, 00111
\end{aligned}$$

$$[\Delta(\mathbf{m})] = 1^{14} \times 1^4 \cdot 2^3 = 1^{18} \cdot 2^3$$

$$\mathbf{m} = H_1 \oplus 311, 221, 2111 : 12 = H_3 \oplus H_3 : 6 = 2H_1 \oplus EO_4 : 3$$

$$\begin{aligned}
42, 221\bar{1}, 2111\bar{1} &= 32, 2111, 21110 \oplus 10, 0100, 00001 = 32, 1211, 21110 \oplus 10, 1000, 00001 \\
&= 10, 0001, 10000 \oplus 32, 2210, 11111 = 31, 1111, 11110 \oplus 11, 1100, 10001 \\
&= 21, 1101, 11100 \oplus 21, 1110, 10011 = 21, 1101, 11010 \oplus 21, 1110, 10101 \\
&= 21, 1101, 10110 \oplus 21, 1110, 11001 \\
&\xrightarrow{2} 22, 0211, 01111 \rightarrow 12, 0111, 00111
\end{aligned}$$

$$[\Delta(\mathbf{m})] = 1^{14} \times 1^6 \cdot 2^2 = 1^{20} \cdot 2^2$$

$$\begin{aligned}
\mathbf{m} &= H_1 \oplus 32, 2111, 2111 : 8 = H_1 \oplus EO_4 : 2 = H_2 \oplus H_4 : 4 \\
&= H_3 \oplus H_3 : 6 = 2H_1 \oplus EO_4 : 2
\end{aligned}$$

$$\begin{aligned}
33, 311\bar{1}, 2111\bar{1} &= 32, 2111, 21110 \oplus 01, 1000, 00001 = 23, 2111, 21110 \oplus 10, 1000, 00001 \\
&= 22, 2101, 11110 \oplus 11, 1010, 10001 = 22, 2011, 11110 \oplus 11, 1100, 10001 \\
&= 11, 1001, 11000 \oplus 22, 2110, 10111 = 11, 1001, 10100 \oplus 22, 2110, 11011 \\
&= 11, 1001, 10010 \oplus 22, 2110, 11101 \\
&\xrightarrow{2} 13, 1111, 01111
\end{aligned}$$

$$[\Delta(\mathbf{m})] = 1^{16} \times 1^4 \cdot 2^2 = 1^{20} \cdot 2^2$$

$$\mathbf{m} = H_1 \oplus 32, 2111, 2111 : 8 = H_2 \oplus EO_4 : 12 = 2H_1 \oplus H_4 : 2$$

$$\begin{aligned}
32\bar{1}, 311\bar{1}, 3111 &= 221, 3110, 2111 \oplus 100, 0001, 1000 = 001, 1000, 1000 \oplus 320, 2111, 2111 \\
&= 211, 2110, 2110 \oplus 110, 1001, 1001 = 211, 2110, 2101 \oplus 110, 1001, 1010 \\
&= 211, 2110, 2011 \oplus 110, 1001, 1100 \\
&\xrightarrow{3} 021, 0111, 0111
\end{aligned}$$

$$[\Delta(\mathbf{m})] = 1^9 \times 1^7 \cdot 2 \cdot 3 = 1^{16} \cdot 2 \cdot 3$$

$$\begin{aligned}
\mathbf{m} &= H_1 \oplus 221, 2111, 311 : 6 = H_1 \oplus 32, 2111, 2111 : 1 \\
&= H_2 \oplus 211, 211, 211 : 9 = 2H_1 \oplus H_4 : 1 = 3H_1 \oplus H_3 : 1
\end{aligned}$$

$$\begin{aligned}
321, 311\bar{1}, 311\underline{1} &= 100, 0001, 1000 \oplus 221, 3110, 2111 = 221, 2111, 3110 \oplus 100, 1000, 0001 \\
&= 211, 2101, 2110 \oplus 110, 1010, 1001 = 211, 2011, 2110 \oplus 110, 1100, 1001 \\
&= 110, 1001, 1100 \oplus 211, 2110, 2011 = 110, 1001, 1010 \oplus 211, 2110, 2101
\end{aligned}$$

$$\begin{aligned}
33, 221\bar{1}, 221\underline{1} &= 22, 1111, 2110 \oplus 11, 1100, 1001 = 22, 1111, 1210 \oplus 11, 1100, 0101 \\
&= 21, 1101, 1110 \oplus 12, 1110, 1011 = 12, 1101, 1110 \oplus 21, 1110, 1011 \\
&= 11, 1001, 1100 \oplus 22, 1210, 1111 = 11, 0101, 1100 \oplus 22, 2110, 1111 \\
&\xrightarrow{1} 23, 1211, 1211 \rightarrow 21, 1011, 1011
\end{aligned}$$

$$[\Delta(\mathbf{m})] = 1^{16} \cdot 2 \times 1^4 = 1^{20} \cdot 2$$

$$\begin{aligned}
\mathbf{m} &= H_1 \oplus 32, 2111, 2111 : 8 = H_2 \oplus EO_4 : 8 = H_3 \oplus H_3 : 4 \\
&= 2(11, 1100, 1100) \oplus 11, 0011, 0011 : 1
\end{aligned}$$

We show all the rigid decompositions of the following simply reducible partitions of order 6, which also correspond to the reducibility of the universal models.

$$\begin{aligned}
42, 222, 111111 &= 32, 122, 011111 \oplus 10, 100, 100000 \\
&= 21, 111, 111000 \oplus 21, 111, 000111 \\
&\xrightarrow{1} 32, 122, 011111 \rightarrow 22, 112, 001111 \rightarrow 12, 111, 000111
\end{aligned}$$

$$[\Delta(\mathbf{m})] = 1^{28}$$

$$\mathbf{m} = H_1 \oplus EO_5 : 18 = H_3 \oplus H_3 : 10$$

$$\begin{aligned}
33, 222, 21111 &= 23, 122, 11111 \oplus 10, 100, 10000 \\
&= 22, 112, 10111 \oplus 11, 110, 11000 \\
&= 21, 111, 11100 \oplus 12, 111, 10011 \\
&\xrightarrow{1} 23, 122, 11111 \rightarrow 22, 112, 01111 \rightarrow 12, 111, 00111
\end{aligned}$$

$$[\Delta(\mathbf{m})] = 1^{24}$$

$$\mathbf{m} = H_1 \oplus EO_5 : 6 = H_2 \oplus EO_4 : 12 = H_3 \oplus H_3 : 6$$

**15.9. Submaximal series and minimal series.** The rigid tuples  $\mathbf{m} = \{m_{j,\nu}\}$  satisfying

$$(15.35) \quad \#\{m_{j,\nu}; 0 < m_{j,\nu} < \text{ord } \mathbf{m}\} \geq \text{ord } \mathbf{m} + 5$$

are classified by Roberts [Ro]. They are the tuples of type  $H_n$  and  $P_n$  which satisfy

$$(15.36) \quad \#\{m_{j,\nu}; 0 < m_{j,\nu} < \text{ord } \mathbf{m}\} = 2 \text{ord } \mathbf{m} + 2$$

and those of 13 series  $A_n = EO_n, B_n, C_n, D_n, E_n, F_n, G_{2m}, I_n, J_n, K_n, L_{2m+1}, M_n, N_n$  called *submaximal series* which satisfy

$$(15.37) \quad \#\{m_{j,\nu}; 0 < m_{j,\nu} < \text{ord } \mathbf{m}\} = \text{ord } \mathbf{m} + 5.$$

The series  $H_n$  and  $P_n$  are called *maximal series*.

We examine these rigid series and give enough information to analyze the series, which will be sufficient to construct differential equations including their confluences, integral representation and series expansion of solutions and get connection coefficients and the condition of their reducibility.

In fact from the following list we easily get all the direct decompositions and Katz's operations decreasing the order. The number over an arrow indicates the difference of the orders. We also indicate Yokoyama's reduction for systems of



Okubo normal form using extension and restriction, which are denoted  $E_i$  and  $R_i$  ( $i = 0, 1, 2$ ), respectively (cf. [Yo2]). Note that the inverse operations of  $E_i$  are  $R_i$ , respectively. In the following we put

$$(15.38) \quad \begin{aligned} u_{P_m} &= \partial^{-\mu} x^{\lambda_0} (1-x)^{\lambda_1} (c_2-x)^{\lambda_2} \cdots (c_{m-1}-x)^{\lambda_{m-1}}, \\ u_{H_2} &= u_{P_2}, \\ u_{H_{m+1}} &= \partial^{-\mu^{(m)}} x^{\lambda_0^{(m)}} u_{H_m}. \end{aligned}$$

We give all the decompositions

$$(15.39) \quad \mathbf{m} = \text{idx}(\mathbf{m}', \mathbf{m}) \cdot \mathbf{m}' \oplus \mathbf{m}''$$

for  $\alpha_{\mathbf{m}'} \in \Delta(\mathbf{m})$ . Here we will not distinguish between  $\mathbf{m}' \oplus \mathbf{m}''$  and  $\mathbf{m}'' \oplus \mathbf{m}'$  when  $\text{idx}(\mathbf{m}', \mathbf{m}) = 1$ . Moreover note that the inequality assumed for the formula  $[\Delta(\mathbf{m})]$  below assures that the given tuple of partition is monotone.

15.9.1.  $B_n$ . ( $B_{2m+1} = \text{III}_m$ ,  $B_{2m} = \text{II}_m$ ,  $B_3 = H_3$ ,  $B_2 = H_2$ )

$$\begin{aligned} u_{B_{2m+1}} &= \partial^{-\mu'} (1-x)^{\lambda'} u_{H_{m+1}} \\ m^2 1, m+11^m, m1^{m+1} &= 10, 10, 01 \oplus mm - 11, m1^m, m1^m \\ &= 01, 10, 10 \oplus m^2, m1^m, m - 11^{m+1} \\ &= 1^2 0, 11, 11 \oplus (m-1)^2 1, m1^{m-1}, m - 11^m \\ [\Delta(B_{2m+1})] &= 1^{(m+1)^2} \times 1^{m+2} \cdot m^2 = 1^{m^2+3m+3} \cdot m^2 \\ B_{2m+1} &= H_1 \oplus B_{2m} & : 2(m+1) \\ &= H_1 \oplus C_{2m} & : 1 \\ &= H_2 \oplus B_{2m-1} & : m(m+1) \\ &= mH_1 \oplus H_{m+1} & : 2 \\ \\ u_{B_{2m}} &= \partial^{-\mu'} x^{\lambda'} (1-x)^{\lambda''} u_{H_m} \\ mm - 11, m1^m, m1^m &= 100, 01, 10 \oplus (m-1)^2 1, m1^{m-1}, m - 11^m \\ &= 001, 10, 10 \oplus mm - 10, m - 11^m, m - 11^m \\ &= 110, 11, 11 \oplus m - 1m - 21, m - 11^{m-1}, m - 11^{m-1} \\ [\Delta(B_{2m})] &= 1^{m^2} \times 1^{2m+1} \cdot (m-1) = 1^{(m+1)^2} \cdot (m-1) \cdot m \\ B_{2m} &= H_1 \oplus B_{2m-1} & : 2m \\ &= H_1 \oplus C_{2m-2} & : 1 \\ &= H_2 \oplus B_{2m-2} & : m^2 \\ &= (m-1)H_1 \oplus H_{m+1} & : 1 \\ &= mH_1 \oplus H_m & : 1 \\ \\ B_{2m+1} &\xrightarrow[R2E0]{m} H_{m+1}, \quad B_n \xrightarrow{1} B_{n-1}, \quad B_n \xrightarrow{1} C_{n-1} \\ B_{2m} &\xrightarrow[R1E0]{m} H_m, \quad B_{2m} \xrightarrow{m-1} H_{m+1} \end{aligned}$$

15.9.2. *An example.* Using the example of type  $B_{2m+1}$ , we explain how we get explicit results from the data written in §15.9.1. The Riemann scheme of type

$B_{2m+1}$  is

$$\begin{pmatrix} \infty & 0 & 1 \\ [\lambda_{0,1}]_{(m)} & [\lambda_{1,1}]_{(m+1)} & [\lambda_{2,1}]_{(m)} \\ [\lambda_{0,2}]_{(m)} & \lambda_{1,2} & \lambda_{2,2} \\ \lambda_{0,3} & \vdots & \vdots \\ & \lambda_{1,m+1} & \lambda_{2,m+2} \end{pmatrix},$$

$$\sum_{j=0}^p \sum_{\nu=1}^{n_j} m_{j,\nu} \lambda_{j,\nu} = 2m \quad (\text{Fuchs relation}).$$

Theorem 12.13 says that the corresponding equation is irreducible if and only if any value of the following linear functions is not an integer.

$$\begin{aligned} L_{i,\nu}^1 &:= \lambda_{0,i} + \lambda_{1,1} + \lambda_{2,\nu} \quad (i = 1, 2, \nu = 2, \dots, m+2), \\ L^2 &:= \lambda_{0,3} + \lambda_{1,1} + \lambda_{2,1}, \\ L_{\mu,\nu}^3 &:= \lambda_{0,1} + \lambda_{0,2} + \lambda_{1,1} + \lambda_{1,\mu} + \lambda_{2,1} + \lambda_{2,\nu} - 1 \\ &\quad (\mu = 2, \dots, m+1, \nu = 2, \dots, m+2), \\ L_i^4 &:= \lambda_{0,i} + \lambda_{1,1} + \lambda_{2,1} \quad (i = 1, 2). \end{aligned}$$

Here  $L_{i,\nu}^1$  (resp.  $L^2$ ) correspond to the terms 10,01,01 and  $H_1 \oplus B_{2m} : 2(m+1)$  (resp. 01,10,10 and  $H_1 \oplus C_{2m} : 1$ ) in §15.9.1.

It follows from Theorem 8.13 and Theorem 12.13 that the Fuchsian differential equation with the above Riemann scheme belongs to the universal operator if

$$L_i^4 \notin \{-1, -2, \dots, 1-m\} \quad (i = 1, 2).$$

Theorem 14.6 says that the connection coefficient  $c(\lambda_{1,m+1} \rightsquigarrow \lambda_{2,m+2})$  equals

$$\frac{\prod_{\mu=1}^m \Gamma(\lambda_{1,m+1} - \lambda_{1,\mu} + 1) \cdot \prod_{\mu=1}^{m+1} \Gamma(\lambda_{2,\nu} - \lambda_{1,m+2})}{\prod_{i=1}^2 \Gamma(1 - L_{i,m+2}^1) \cdot \prod_{\nu=2}^{m+1} \Gamma(L_{m+1,\nu}^3) \cdot \prod_{\mu=2}^m \Gamma(1 - L_{\mu,m+2}^3)}$$

and

$$\begin{aligned} c(\lambda_{1,m+1} \rightsquigarrow \lambda_{0,3}) &= \frac{\prod_{\mu=1}^m \Gamma(\lambda_{1,m+1} - \lambda_{1,\mu} + 1) \cdot \prod_{i=1}^2 \Gamma(\lambda_{0,i} - \lambda_{0,3})}{\Gamma(1 - L^2) \cdot \prod_{\nu=2}^{m+1} \Gamma(L_{m+1,\nu}^3)}, \\ c(\lambda_{2,m+2} \rightsquigarrow \lambda_{0,3}) &= \frac{\prod_{\nu=1}^{m+1} \Gamma(\lambda_{2,m+2} - \lambda_{1,\nu} + 1) \cdot \prod_{i=1}^2 \Gamma(\lambda_{0,i} - \lambda_{0,3})}{\prod_{i=1}^2 \Gamma(L_{m+2}^1) \cdot \prod_{\nu=2}^{m+1} \Gamma(L_{m+1,\nu}^3)}. \end{aligned}$$

We also explain how we get the data in §15.9.1. Since  $\partial_{max} : B_{2m+1} = \mathbf{m} := mm1, m + 11^m, m1^{m+1} \rightarrow H_{m+1} = \mathbf{m}' := 0m1, 11^m, 01^{m+1}$ , the equality (9.42) shows

$$\begin{aligned} [\Delta(B_{2m+1})] &= [\Delta(H_{m+1})] \cup \{d_{1,1,1}(\mathbf{m})\} \cup \{m'_{j,\nu} - m'_{j,1} > 0\} \\ &= 1^{(m+1)^2} \times m^1 \times 1^{m+2} \cdot m^1 = 1^{(m+1)^2} \times 1^{m+2} \cdot m^2 = 1^{m^2+3m+3} \cdot m^2. \end{aligned}$$

Here we note that  $\{m'_{j,\nu} - m'_{j,1} > 0\} = \{m, 1, 1^{m+1}\} = 1^{m+2} \cdot m^1$  and  $[\Delta(H_{m+1})]$  is given in §15.4.

The decompositions  $mH_1 \oplus H_{m+1}$  and  $B_1 \oplus B_{2m}$  etc. in §15.9.1 are easily obtained and we should show that they are all the decompositions (15.39), whose number is given by  $[\Delta(B_{2m+1})]$ . There are 2 decompositions of type  $mH_1 \oplus H_{m+1}$ , namely,  $B_{2m+1} = mm1, m + 11^m, m1^{m+1} = m(100, 10, 10) \oplus \dots = m(010, 10, 10) \oplus \dots$ , which correspond to  $L_i^4$  for  $i = 1$  and 2. Then the other decompositions are of type  $\mathbf{m}' \oplus \mathbf{m}''$  with rigid tuples  $\mathbf{m}'$  and  $\mathbf{m}''$  whose number equals  $m^2 + 3m + 3$ . The numbers of decompositions  $B_1 \oplus B_{2m}$  etc. given in §15.9.1 are easily calculated

which correspond to  $L_{i,\nu}^1$  etc. and we can check that they give the required number of the decompositions.

15.9.3.  $C_n$ . ( $C_4 = EO_4$ ,  $C_3 = H_3$ ,  $C_2 = H_2$ )

$$\begin{aligned}
u_{C_{2m+1}} &= \partial^{-\mu'} x^{\lambda'} u_{H_{m+1}} \\
m+1m, m1^{m+1}, m1^{m+1} &= 10, 01, 10 \oplus m^2, m1^m, m-11^{m+1} \\
&= 11, 11, 11 \oplus m(m-1), m-11^m m-11^m \\
[\Delta(C_{2m+1})] &= 1^{(m+1)^2} \times 1^{2m+2} \cdot m \cdot (m-1) \\
&= 1^{(m+1)(m+3)} \cdot m \cdot (m-1) \\
C_{2m+1} &= H_1 \oplus C_{2m} && : 2m+2 \\
&= H_2 \oplus C_{2m-2} && : (m+1)^2 \\
&= mH_1 \oplus H_{m+1} && : 1 \\
&= (m-1)H_1 \oplus H_{m+2} && : 1 \\
u_{C_{2m}} &= \partial^{-\mu'} x^{\lambda'} (1-x)^{-\lambda_1-\mu-\mu^{(2)}-\dots-\mu^{(m)}} u_{H_{m+1}} \\
m^2, m1^m, m-11^{m+1} &= 1, 10, 01 \oplus mm-1, m-11^{m-1}, m-11^{m-1} \\
&= 1^2, 11, 11 \oplus (m-1)^2, m-11^{m-1}, m-21^m \\
[\Delta(C_{2m})] &= 1^{(m+1)^2} \times 1^{m+1} \cdot (m-1)^2 = 1^{m^2+3m+2} \cdot (m-1)^2 \\
C_{2m} &= H_1 \oplus C_{2m-1} && : 2m+2 \\
&= H_2 \oplus C_{2m-2} && : m(m+1) \\
&= (m-1)H_1 \oplus H_{m+1} && : 2 \\
C_{2m+1} &\xrightarrow[R_2E_0R_0E_0]{m} H_{m+1}, & C_{2m+1} &\xrightarrow[m-1]{m-1} H_{m+2} \\
C_{2m} &\xrightarrow[R_1E_0R_0E_0]{m-1} H_{m+1}, & C_n &\xrightarrow{1} C_{n-1}
\end{aligned}$$

15.9.4.  $D_n$ . ( $D_6 = X_6$  : Extra case,  $D_5 = EO_5$ )

$$\begin{aligned}
u_{D_5} &= \partial^{-\mu_5} (1-x)^{-\lambda_3-\mu_3-\mu_4} u_{E_4} \\
u_{D_6} &= \partial^{-\mu_6} (1-x)^{-\lambda_1-\mu-\mu_5} u_{D_5} \\
u_{D_n} &= \partial^{-\mu_n} (1-x)^{-\lambda'_n} u_{D_{n-2}} \quad (n \geq 7) \\
(2m-1)2, 2^m 1, 2^{m-2} 1^5 &= 10, 01, 10 \oplus (2m-2)2, 2^m, 2^{m-3} 1^6 \\
&= 10, 10, 01 \oplus (2m-2)2, 2^{m-1} 1^2, 2^{m-3} 1^4 \\
&= (m-1)1, 1^m 0, 1^{m-2} 1^2 \oplus m1, 1^m 1, 1^{m-2} 1^3 \\
m \geq 2 \Rightarrow [\Delta(D_{2m+1})] &= 1^{6m+2} \cdot 2^{(m-1)(m-3)} \times 1^6 \cdot 2^{2m-3} = 1^{6m+8} \cdot 2^{m(m-2)} \\
D_{2m+1} &= H_1 \oplus D_{2m} && : m-2 \\
&= H_1 \oplus E_{2m} && : 5m \\
&= H_m \oplus H_{m+1} && : 10 \\
&= 2H_1 \oplus D_{2m-1} && : m(m-2) \\
(2m-2)2, 2^m, 2^{m-3} 1^6 &= 10, 1, 01 \oplus (2m-3)2, 2^{m-1} 1, 2^{m-3} 1^5 \\
&= (m-1)1, 1^m, 1^{m-3} 1^3 \oplus (m-1)1, 1^m, 1^{m-3} 1^3
\end{aligned}$$

$$\begin{aligned}
m \geq 3 \Rightarrow [\Delta(D_{2m})] &= 1^{6m+6} \cdot 2^{(m-1)(m-4)} \times 1^6 \cdot 2^{2m-4} = 1^{6m+10} \cdot 2^{m(m-3)} \\
D_{2m} &= H_1 \oplus D_{2m-1} && : 6m \\
&= H_m \oplus H_m && : 10 \\
&= 2H_1 \oplus D_{2m-2} && : m(m-3) \\
D_n &\xrightarrow[R2E0]{2} D_{n-2}, \quad D_n \xrightarrow{1} D_{n-1}, \quad D_{2m+1} \xrightarrow{1} E_{2m}
\end{aligned}$$

15.9.5.  $E_n$ . ( $E_5 = C_5$ ,  $E_4 = EO_4$ ,  $E_3 = H_3$ )

$$\begin{aligned}
u_{E_3} &= x^{-\lambda_0 - \mu - \mu_3} \partial^{-\mu_3} (1-x)^{\lambda'_3} u_{H_2} \\
u_{E_4} &= \partial^{-\mu_4} u_{E_3} \\
u_{E_n} &= \partial^{-\mu_n} (1-x)^{\lambda'_n} u_{E_{n-2}} \quad (n \geq 5) \\
(2m-1)2, 2^{m-1}1^3, 2^{m-1}1^3 &= 10, 01, 10 \oplus (2m-2)2, 2^{m-1}1^2, 2^{m-2}1^4 \\
&= (m-1)1, 1^{m-1}1, 1^{m-1}1 \oplus m1, 1^{m-1}1^3, 1^{m-1}1^2 \\
&= (m-2)1, 1^{m-1}0, 1^{m-1}0 \oplus (m+1)1, 1^{m-1}1^2, 1^{m-1}1^3 \\
m \geq 2 \Rightarrow [\Delta(E_{2m+1})] &= 1^{6m-2} \cdot 2^{(m-2)^2} \times 1^6 \cdot 2^{2m-3} = 1^{6m+4} \cdot 2^{(m-1)^2} \\
E_{2m+1} &= H_1 \oplus E_{2m} && : 6(m-1) \\
&= H_{m-1} \oplus H_{m+2} && : 1 \\
&= H_m \oplus H_{m+1} && : 9 \\
&= 2H_1 \oplus E_{2m-1} && : (m-1)^2 \\
(2m-2)2, 2^{m-1}1^2, 2^{m-2}1^4 &= 10, 10, 01 \oplus (2m-3)2, 2^{m-2}1^3, 2^{m-2}1^3 \\
&= 10, 01, 10 \oplus (2m-3)2, 2^{m-1}1, 2^{m-3}1^5 \\
&= (m-2)1, 1^{m-1}0, 1^{m-2}1 \oplus m1, 1^{m-1}1^2, 1^{m-2}1^3 \\
&= (m-1)1, 1^{m-1}1, 1^{m-2}1^2 \oplus (m-1)1, 1^{m-1}1, 1^{m-2}1^2 \\
m \geq 2 \Rightarrow [\Delta(E_{2m})] &= 1^{6m-4} \cdot 2^{(m-2)(m-3)} \times 1^6 \cdot 2^{2m-4} = 1^{6m+2} \cdot 2^{(m-1)(m-2)} \\
E_{2m} &= H_1 \oplus E_{2m-1} && : 4(m-1) \\
&= H_1 \oplus D_{2m-1} && : 2(m-2) \\
&= H_{m-1} \oplus H_{m+1} && : 4 \\
&= H_m \oplus H_m && : 6 \\
&= 2H_1 \oplus E_{2m-2} && : (m-1)(m-2) \\
E_n &\xrightarrow[R2E0]{2} E_{n-2}, \quad E_n \xrightarrow{1} E_{n-1}, \quad E_{2m} \xrightarrow{1} D_{2m-1}
\end{aligned}$$

15.9.6.  $F_n$ . ( $F_5 = B_5$ ,  $F_4 = EO_4$ ,  $F_3 = H_3$ )

$$\begin{aligned}
u_{F_3} &= u_{H_3} \\
u_{F_4} &= \partial^{-\mu_4} (1-x)^{-\lambda_1 - \lambda_0^{(3)} - \mu^{(3)}} u_{F_3} \\
u_{F_n} &= \partial^{-\mu_n} (1-x)^{\lambda'_n} u_{F_{n-2}} \quad (n \geq 5) \\
(2m-1)1^2, 2^m1, 2^{m-1}1^3 &= 10, 10, 01 \oplus (2m-2)1^2, 2^{m-1}1^2, 2^{m-1}1^2 \\
&= 10, 01, 10 \oplus (2m-2)1^2, 2^m, 2^{m-2}1^4 \\
&= (m-1)1, 1^m0, 1^{m-1}1 \oplus m1, 1^m1, 1^{m-1}1^2
\end{aligned}$$

$$m \geq 1 \Rightarrow [\Delta(F_{2m+1})] = 1^{4m+1} \cdot 2^{(m-1)(m-2)} \times 1^4 \cdot 2^{2m-2} = 1^{4m+5} \cdot 2^{m(m-1)}$$

$$\begin{aligned} F_{2m+1} &= H_1 \oplus G_{2m} && : 3m \\ &= H_1 \oplus F_{2m} && : m-1 \\ &= H_m \oplus H_{m+1} && : 6 \\ &= 2H_1 \oplus F_{2m-1} && : m(m-1) \end{aligned}$$

$$\begin{aligned} (2m-2)1^2, 2^m, 2^{m-2}1^4 &= 10, 1, 01 \oplus (2m-3)1^2, 2^{m-1}1, 2^{m-2}1^3 \\ &= (m-1)1, 1^m, 1^{m-2}1^2 \oplus (m-1)1, 1^m, 1^{m-2}1^2 \end{aligned}$$

$$m \geq 2 \Rightarrow [\Delta(F_{2m})] = 1^{4m+2} \cdot 2^{(m-1)(m-3)} \times 1^4 \cdot 2^{2m-3} = 1^{4m+6} \cdot 2^{m(m-2)}$$

$$\begin{aligned} F_{2m} &= H_1 \oplus F_{2m-1} && : 4m \\ &= H_m \oplus H_m && : 6 \\ &= 2H_1 \oplus F_{2m-2} && : m(m-2) \end{aligned}$$

$$F_n \xrightarrow[R2E0]{2} F_{n-2}, \quad F_n \xrightarrow{1} F_{n-1}, \quad F_{2m+1} \xrightarrow{1} G_{2m}$$

15.9.7.  $G_{2m}$ . ( $G_4 = B_4$ )

$$u_{G_2} = u_{H_2}$$

$$u_{G_{2m}} = \partial^{-\mu_{2m}} (1-x)^{\lambda_{2m}} u_{G_{2m-2}}$$

$$\begin{aligned} (2m-2)1^2, 2^{m-1}1^2, 2^{m-1}1^2 &= 10, 01, 01 \oplus (2m-3)1^2, 2^{m-1}1, 2^{m-2}1^3 \\ &= (m-2)1, 1^{m-1}0, 1^{m-1}0 \oplus m1, 1^{m-1}1^2, 1^{m-1}1^2 \end{aligned}$$

$$m \geq 2 \Rightarrow [\Delta(G_{2m})] = 1^{4m-2} \cdot 2^{(m-2)^2} \times 1^4 \cdot 2^{2m-3} = 1^{4m+2} \cdot 2^{(m-1)^2}$$

$$\begin{aligned} G_{2m} &= H_1 \oplus F_{2m-1} && : 4m \\ &= H_{m-1} \oplus H_{m+1} && : 2 \\ &= 2H_1 \oplus G_{2m-2} && : (m-1)^2 \end{aligned}$$

$$G_{2m} = H_1 \oplus F_{2m-1} = H_{m-1} \oplus H_{m+1}$$

$$G_{2m} \xrightarrow[R2E0]{2} G_{2(m-1)}, \quad G_{2m} \xrightarrow{1} F_{2m-1}$$

15.9.8.  $I_n$ . ( $I_{2m+1} = \text{III}_m^*$ ,  $I_{2m} = \text{II}_m^*$ ,  $I_3 = P_3$ )

$$u_{I_{2m+1}} = \partial^{-\mu'} x^{\lambda'} (c-x)^{\lambda''} u_{H_m}$$

$$(2m)1, m+1m, m+11^m, m+11^m$$

$$= 10, 10, 10, 01 \oplus (2m-1)1, mm, m1^m, m+11^{m-1}$$

$$= 20, 11, 11, 11 \oplus (2m-2)1, mm-1, m1^{m-1}, m1^{m-1}$$

$$[\Delta(I_{2m+1})] = 1^{m^2} \times 1^{2m} \cdot m \cdot (m+1) = 1^{m^2+2m} \cdot m \cdot (m+1)$$

$$\begin{aligned} I_{2m+1} &= H_1 \oplus I_{2m} && : 2m \\ &= H_2 \oplus I_{2m-1} && : m^2 \\ &= mH_1 \oplus H_{m+1} && : 1 \\ &= (m+1)H_1 \oplus H_m && : 1 \end{aligned}$$

$$u_{I_{2m}} = \partial^{-\mu'} (1-cx)^{\lambda''} u_{H_m}$$

$$(2m-1)1, mm, m1^m, m+11^{m-1}$$

$$= 10, 01, 01, 10 \oplus (2m-2)1, mm-1, m1^{m-1}, m1^{m-1}$$

$$= 20, 11, 11, 11 \oplus (2m-3)1, m-1m-1, m-11^{m-1}, m1^{m-2}$$

$$\begin{aligned}
[\Delta(I_{2m})] &= 1^{m^2} \times 1^m \cdot m^2 = 1^{m(m+1)} \cdot m^2 \\
I_{2m} &= H_1 \oplus I_{2m-1} \quad : 2m \\
&= H_2 \oplus I_{2m-2} \quad : m(m-1) \\
&= mH_1 \oplus H_m \quad : 2 \\
I_{2m+1} &\xrightarrow{R1E0} H_m, \quad I_{2m+1} \xrightarrow{R2E0} H_{m+1}, \quad I_{2m} \xrightarrow{R1E0} H_m, \quad I_n \xrightarrow{R1E0} I_{n-1} \\
I_{2m+1} &\xrightarrow{R1E0} I_{2m} \xrightarrow{R2E0} I_{2m-2}
\end{aligned}$$

15.9.9.  $J_n$ . ( $J_4 = I_4$ ,  $J_3 = P_3$ )

$$\begin{aligned}
u_{J_2} &= (c-x)^{\lambda'} u_{H_2} \\
u_{J_3} &= u_{P_3} \\
u_{J_n} &= \partial^{-\mu'_n} x^{\lambda'_n} u_{J_{n-2}} \quad (n \geq 4) \\
(2m)1, (2m)1, 2^m 1, 2^m 1 \\
&= 10, 10, 01, 10 \oplus (2m-1)1, (2m-1)1, 2^m, 2^{m-1} 11 \\
&= (m-1)1, m0, 1^m 0, 1^m 0 \oplus (m+1), m1, 1^m 1, 1^m 1 \\
[\Delta(J_{2m+1})] &= 1^{2m} \cdot 2^{(m-1)^2} \times 1^2 \cdot 2^{2m-1} = 1^{2m+2} \cdot 2^{m^2} \\
J_{2m+1} &= H_1 \oplus J_{2m} \quad : 2m \\
&= H_m \oplus H_{m+1} \quad : 2 \\
&= 2H_1 \oplus J_{2m-2} \quad : m^2 \\
(2m-1)1, (2m-1)1, 2^m, 2^{m-1} 1^2 \\
&= 10, 10, 1, 01 \oplus (2m-2)1, (2m-2)1, 2^{m-1} 1, 2^{m-1} 1 \\
&= (m-1)1, m0, 1^m, 1^{m-1} 1 \oplus m0, (m-1)1, 1^m, 1^{m-1} 1 \\
[\Delta(J_{2m})] &= 1^{2m} \cdot 2^{(m-1)(m-2)} \times 1^2 \cdot 2^{2m-2} = 1^{2m+2} \cdot 2^{m(m-1)} \\
J_{2m} &= H_1 \oplus J_{2m-1} \quad : 2m \\
&= H_m \oplus H_m \quad : 2 \\
&= 2H_1 \oplus J_{2m-2} \quad : m(m-1) \\
J_n &\xrightarrow{R2E0} J_{n-2} \quad (n \geq 6), \quad J_n \xrightarrow{R1E0} J_{n-1}
\end{aligned}$$

15.9.10.  $K_n$ . ( $K_5 = M_5$ ,  $K_4 = I_4$ ,  $K_3 = P_3$ )

$$\begin{aligned}
u_{K_{2m+1}} &= \partial^{\mu+\lambda'+\lambda''} (c'-x)^{\lambda'} (c''-x)^{\lambda''} u_{P_m} \\
m+1m, m+1m, (2m)1, (2m)1, (2m)1, \dots &\in \mathcal{P}_{m+3}^{(2m+1)} \\
&= 11, 11, 11, 20, 20, \dots \oplus mm-1, mm-1, (2m-1)0, (2m-2)1, (2m-2)1, \dots \\
[\Delta(K_{2m+1})] &= 1^{m+1} \cdot (m-1) \times m^2 \cdot (m+1) = 1^{m+1} \cdot (m-1) \cdot m^2 \cdot (m+1) \\
K_{2m+1} &= H_2 \oplus K_{2m-1} \quad : m+1 \\
&= (m-1)H_1 \oplus P_{m+2} \quad : 1 \\
&= mH_1 \oplus P_{m+1} \quad : 2 \\
&= (m+1)H_1 \oplus P_m \quad : 1
\end{aligned}$$

$$\begin{aligned}
u_{K_{2m}} &= \partial^{-\mu'} (c'-x)^{\lambda'} u_{P_m} \\
mm, mm-11, (2m-1)1, (2m-1)1, \dots &\in \mathcal{P}_{m+2}^{(2m)} \\
&= 01, 001, 10, 10, 10, \dots \oplus mm-1, mm-10, (2m-2)1, (2m-2)1, \dots
\end{aligned}$$

$$\begin{aligned}
&= 11, 110, 11, 20, 20, \dots \oplus m-1m-1, m-1m-21, (2m-2)0, (2m-3)1, \dots \\
[\Delta(K_{2m})] &= 1^{m+1} \cdot (m-1) \times 1 \cdot (m-1) \cdot m^2 = 1^{m+2} \cdot (m-1)^2 \cdot m^2 \\
K_{2m} &= H_1 \oplus K_{2m-1} && : 2 \\
&= H_2 \oplus K_{2m-2} && : m \\
&= (m-1)H_1 \oplus P_{m+1} && : 2 \\
&= mH_1 \oplus P_m && : 2 \\
K_{2m+1} &\xrightarrow{m+1} P_m, \quad K_{2m+1} \xrightarrow{m}_{R1} P_{m+1}, \quad K_{2m+1} \xrightarrow{m-1} P_{m+2} \\
K_{2m} &\xrightarrow{m}_{R1} P_m, \quad K_{2m} \xrightarrow{m-1} P_{m+1}, \quad K_{2m} \xrightarrow{1} K_{2m-1}
\end{aligned}$$

15.9.11.  $L_{2m+1}$ . ( $L_5 = J_5$ ,  $L_3 = H_3$ )

$$\begin{aligned}
u_{L_{2m+1}} &= \partial^{-\mu'} x^{\lambda'} u_{P_{m+1}} \\
mm1, mm1, (2m)1, (2m)1, \dots &\in \mathcal{P}_{m+2}^{(2m+1)} \\
&= 001, 010, 10, 10, \dots \oplus mm0, mm-11, (2m-1)1, (2m-1)1, \dots \\
&= 110, 110, 11, 20, \dots \oplus m-1m-10, m-1m-11, (2m-1)0, (2m-2)1, \dots \\
[\Delta(L_{2m+1})] &= 1^{m+2} \cdot m \times 1^2 \cdot m^3 = 1^{m+4} \cdot m^4 \\
L_{2m+1} &= H_1 \oplus K_{2m} && : 4 \\
&= H_2 \oplus L_{2m-1} && : m \\
&= mH_1 \oplus P_{m+1} && : 4 \\
L_{2m+1} &= H_1 \oplus K_{2m}, \quad L_{2m+1} = H_2 \oplus L_{2m-1} \\
L_{2m+1} &\xrightarrow{m}_{R2E0} P_{m+1}, \quad L_{2m+1} \xrightarrow{1} K_{2m}
\end{aligned}$$

15.9.12.  $M_n$ . ( $M_5 = K_5$ ,  $M_4 = I_4$ ,  $M_3 = P_3$ )

$$\begin{aligned}
u_{M_{2m+1}} &= \partial^{\mu+\lambda'_3+\dots+\lambda'_{m+2}} (c_3-x)^{\lambda'_3} \dots (c_{m+2}-x)^{\lambda'_{m+2}} u_{H_2} \\
(2m)1, (2m)1, (2m)1, (2m-1)2, (2m-1)2, \dots &\in \mathcal{P}_{m+3}^{(2m+1)} \\
&= m-11, m0, m0, m-11, m-11, \dots \oplus m+10, m1, m1, m1, m1, \dots \\
&= m-10, m-10, m-10, m-21, m-21, \dots \\
&\quad \oplus m+11, m+11, m+11, m+11, m+11, \dots \\
[\Delta(M_{2m+1})] &= 1^4 \times 2^m \cdot (2m-1) = 1^4 \cdot 2^m \cdot (2m-1) \\
M_{2m+1} &= P_{m-1} \oplus P_{m+2} && : 1 \\
&= P_m \oplus P_{m+1} && : 3 \\
&= 2H_1 \oplus M_{2m-1} && : m \\
&= (2m-1)H_1 \oplus H_2 && : 1 \\
u_{M_{2m}} &= \partial^{-\mu'} (c_3-x)^{\lambda'_3} \dots (c_{m+1}-x)^{\lambda'_{m+1}} u_{H_2} \\
(2m-2)1^2, (2m-1)1, (2m-1)1, (2m-2)2, \dots &\in \mathcal{P}_{m+2}^{(2m)} \\
&= 01, 10, 10, 10, \dots \oplus (2m-2)1, (2m-2)1, (2m-2)1, (2m-3)2, \dots \\
&= m-21, m-10, m-10, m-21, \dots \oplus m1, m1, m1, m1, \dots \\
&= m-11, m-11, m0, m-11, \dots \oplus m-11, m0, m-11, m-11, \dots
\end{aligned}$$

$$\begin{aligned}
[\Delta(M_{2m})] &= 1^4 \times 1^2 \cdot 2^{m-1} \cdot (2m-2) = 1^6 \cdot 2^{m-1} \cdot (2m-2) \\
M_{2m} &= H_1 \oplus M_{2m-1} && : 2 \\
&= P_{m-1} \oplus P_{m+1} && : 2 \\
&= P_m \oplus P_m && : 2 \\
&= 2H_1 \oplus M_{2m-2} && : m-1 \\
&= (2m-2)H_1 \oplus H_2 && : 1 \\
M_n &\xrightarrow{n-2} H_2, \quad M_n \xrightarrow{2} M_{n-2}, \quad M_{2m} \xrightarrow[R1E0]{1} M_{2m-1} \xrightarrow[R1]{} M_{2m-3}
\end{aligned}$$

15.9.13.  $N_n$ . ( $N_6 = IV^*$ ,  $N_5 = I_5$ ,  $N_4 = G_4$ ,  $N_3 = H_3$ )

$$\begin{aligned}
u_{N_{2m+1}} &= \partial^{-\mu'} x^{\lambda'} (c_3 - x)^{\lambda'_3} \cdots (c_{m+1} - x)^{\lambda'_{m+1}} u_{H_2} \\
(2m-1)1^2, (2m-1)1^2, (2m)1, (2m-1)2, (2m-1)2, \dots &\in \mathcal{P}_{m+2}^{(2m+1)} \\
&= 10, 01, 10, 10, 10 \dots \\
&\oplus (2m-2)1^2, (2m-1)1, (2m-1)1, (2m-2)2, (2m-2)2, \dots \\
&= m-11, m-11, m0, m-11, m-11, \dots \oplus m1, m1, m1, m1, m1, \dots \\
[\Delta(N_{2m+1})] &= 1^4 \times 1^4 \cdot 2^{m-1} \cdot (2m-1) = 1^8 \cdot 2^{m-1} \cdot (2m-1) \\
N_{2m+1} &= H_1 \oplus M_{2m} && : 4 \\
&= P_m \oplus P_{m+1} && : 4 \\
&= 2H_1 \oplus N_{2m-1} && : m-1 \\
&= (2m-1)H_1 \oplus H_2 && : 1
\end{aligned}$$

$$\begin{aligned}
u_{N_{2m}} &= \partial^{-\mu'} x^{\lambda'_0} (1-x)^{\lambda'_1} (c_3 - x)^{\lambda'_3} \cdots (c_m - x)^{\lambda'_m} u_{H_2} \quad (m \geq 2) \\
(2m-2)1^2, (2m-2)1^2, (2m-2)1^2, (2m-2)2, (2m-2)2, \dots &\in \mathcal{P}_{m+1}^{(2m)} \\
&= 01, 10, 10, 10, 10 \dots \\
&\oplus (2m-2)1, (2m-3)1^2, (2m-3)1^2, (2m-3)2, (2m-3)2, \dots \\
&= m-11, m-11, m-11, m-11, m-11, \dots \\
&\oplus m-11, m-11, m-11, m-11, m-11, \dots
\end{aligned}$$

$$\begin{aligned}
[\Delta(N_{2m})] &= 1^4 \times 1^6 \cdot 2^{m-2} \cdot (2m-2) = 1^{10} \cdot 2^{m-2} \cdot (2m-2) \\
N_{2m} &= H_1 \oplus N_{2m-1} && : 6 \\
&= P_m \oplus P_m && : 4 \\
&= 2H_1 \oplus N_{2m-2} && : m-2 \\
&= (2m-2)H_1 \oplus H_2 && : 1
\end{aligned}$$

$$N_n \xrightarrow{n-2} H_2, \quad N_n \xrightarrow{2} N_{n-2}, \quad N_{2m+1} \xrightarrow[R1E0]{1} M_{2m}, \quad N_{2m} \xrightarrow[R1E0]{1} N_{2m-1}$$

15.9.14. *minimal series*. The tuple 11, 11, 11 corresponds to Gauss hypergeometric series, which has three parameters. Since the action of additions is easily analyzed, we consider the number of parameters of the equation corresponding to a rigid tuple  $\mathbf{m} = (m_{j,\nu})_{\substack{0 \leq j \leq p \\ 1 \leq \nu \leq n_j}} \in \mathcal{P}_{p+1}^{(n)}$  modulo additions and the Fuchs condition equals

$$(15.40) \quad n_0 + n_1 + \cdots + n_p - (p+1).$$

Here we assume that  $0 < m_{j,\nu} < n$  for  $1 \leq \nu \leq n_j$  and  $j = 0, \dots, p$ .

We call the number given by (15.40) the *effective length* of  $\mathbf{m}$ . The tuple 11, 11, 11 is the unique rigid tuple of partitions whose effective length equals 3. Since the reduction  $\partial_{max}$  never increase the effective length and the tuple  $\mathbf{m} \in \mathcal{P}_3$  satisfying



$\partial_{max} = 11, 11, 11$  is  $21, 111, 111$  or  $211, 211, 211$ , it is easy to see that the non-trivial rigid tuple  $\mathbf{m} \in \mathcal{P}_3$  whose effective length is smaller than 6 is  $H_2$  or  $H_3$ .

The rigid tuple of partitions with the effective length 4 is also uniquely determined by its order, which is

$$(15.41) \quad \begin{aligned} P_{4,2m+1} &: m + 1m, m + 1m, m + 1m, m + 1m \\ P_{4,2m} &: m + 1m - 1, mm, mm, mm \end{aligned}$$

with  $m \in \mathbb{Z}_{>0}$ . Here  $P_{4,2m+1}$  is a generalized Jordan-Pochhammer tuple in Example 12.5 i).

In fact, if  $\mathbf{m} \in \mathcal{P}$  is rigid with the effective length 4, the argument above shows  $\mathbf{m} \in \mathcal{P}_4$  and  $n_j = 2$  for  $j = 0, \dots, 3$ . Then  $2 = \sum_{j=0}^3 m_{j,1}^2 + \sum_{j=0}^3 (n - m_{j,1})^2 - 2n^2$  and  $\sum_{j=0}^3 (n - 2m_{j,1})^2 = 4$  and therefore  $\mathbf{m} = P_{4,2m+1}$  or  $P_{4,2m}$ .

We give decompositions of  $P_{4,n}$ :

$$\begin{aligned} & m + 1, m; m + 1, m; m + 1, m; m + 1, m \\ &= k, k + 1; k + 1, k; k + 1, k; k + 1, k \\ &\quad \oplus m - k + 1, m - k - 1; m - k, m - k; m - k, m - k; m - k, m - k \\ &= 2(k + 1, k; k + 1, k; k + 1, k; \dots) \\ &\quad \oplus m - 2k - 1, m - 2k; m - 2k - 1, m - 2k; m - 2k - 1, m - 2k; \dots \\ [\Delta(P_{4,2m+1})] &= 1^{4m-4} \cdot 2^{m-1} \times 1^4 \cdot 2 = 1^{4m} \cdot 2^m \\ P_{4,2m+1} &= P_{4,2k+1} \oplus P_{4,2(m-k)} \quad : 4 \quad (k = 0, \dots, m - 1) \\ &= 2P_{4,2k+1} \oplus P_{4,2m-4k-1} \quad : 1 \quad (k = 0, \dots, m - 1) \end{aligned}$$

Here  $P_{k,-n} = -P_{k,n}$  and in the above decompositions there appear ‘‘tuples of partitions’’ with negative entries corresponding formally to elements in  $\Delta^{re}$  with (9.12) (cf. Remark 9.11 i)).

It follows from the above decompositions that the Fuchsian equation with the Riemann scheme

$$\left\{ \begin{array}{cccc} \infty & 0 & 1 & c_3 \\ [\lambda_{0,1}]_{(m+1)} & [\lambda_{1,1}]_{(m+1)} & [\lambda_{2,1}]_{(m+1)} & [\lambda_{3,1}]_{(m+1)} \\ [\lambda_{0,2}]_{(m)} & [\lambda_{1,2}]_{(m)} & [\lambda_{2,1}]_{(m)} & [\lambda_{3,2}]_{(m)} \end{array} \right\}$$

$$\sum_{j=0}^4 ((m + 1)\lambda_{j,1} + m\lambda_{j,2}) = 2m \quad (\text{Fuchs relation}).$$

is irreducible if and only if

$$\sum_{j=0}^4 \sum_{\nu=1}^2 (k + \delta_{\nu,1} + (1 - 2\delta_{\nu,1})\delta_{j,i})\lambda_{j,\nu} \notin \mathbb{Z} \quad (i = 0, 1, \dots, 5, k = 0, 1, \dots, m).$$

When  $\mathbf{m} = P_{4,2m}$ , we have the following.

$$\begin{aligned} & m + 1, m - 1; m, m; m, m; m, m \\ &= k + 1, k; k + 1, k; k + 1, k; k + 1, k \\ &\quad \oplus m - k, m - k - 1; m - k - 1, m - k; m - k - 1, m - k; m - k - 1, m - k \\ &= 2(k + 1, k - 1; k, k; k, k; k, k) \\ &\quad \oplus m - 2k - 1, m - 2k + 1; m - 2k, m - 2k; m - 2k, m - 2k; m - 2k; m - 2k \\ [\Delta(P_{4,2m})] &= 1^{4m-4} \cdot 2^{m-1} \times 1^4 = 1^{4m} \cdot 2^{m-1} \\ P_{4,2m} &= P_{4,2k+1}(= k + 1, k; k + 1, k; \dots) \oplus P_{4,2m-2k+1} \quad : 4 \quad (k = 0, \dots, m - 1) \\ &= 2P_{4,2k} \oplus P_{4,2m-4k} \quad : 1 \quad (k = 1, \dots, m - 1) \\ & P_{4,n} \xrightarrow{1} P_{4,n-1}, P_{4,2m+1} \xrightarrow{2} P_{4,2m-1} \end{aligned}$$

Roberts [Ro] classifies the rigid tuples  $\mathbf{m} \in \mathcal{P}_{p+1}$  so that

$$(15.42) \quad \frac{1}{n_0} + \cdots + \frac{1}{n_p} \geq p - 1.$$

They are tuples  $\mathbf{m}$  in 4 series  $\alpha, \beta, \gamma, \delta$ , which are close to the tuples  $r\tilde{E}_6, r\tilde{E}_7, r\tilde{E}_8$  and  $r\tilde{D}_4$ , namely,  $(n_0, \dots, n_p) = (3, 3, 3), (2, 2, 4), (2, 3, 6)$  and  $(2, 2, 2, 2)$ , respectively (cf. (9.45)), and the series are called *minimal series*. Then  $\delta_n = P_{4,n}$  and the tuples in the other three series belong to  $\mathcal{P}_3$ . For example, the tuples  $\mathbf{m}$  of type  $\alpha$  are

$$(15.43) \quad \begin{aligned} \alpha_{3m} &= m + 1mm - 1, m^3, m^3, & \alpha_3 &= H_3, \\ \alpha_{3m \pm 1} &= m^2m \pm 1, m^2m \pm 1, m^2m \pm 1, & \alpha_4 &= B_4, \end{aligned}$$

which are characterized by the fact that their effective lengths equal 6 when  $n \geq 4$ . As in other series, we have the following:

$$\begin{aligned} \alpha_n &\xrightarrow{1} \alpha_{n-1}, \quad \alpha_{3m+1} \xrightarrow{2} \alpha_{3m-1} \\ [\Delta(\alpha_{3m})] &= [\Delta(\alpha_{3m-1})] \times 1^5, \quad [\Delta(\alpha_{3m-1})] = [\Delta(\alpha_{3m-2})] \times 1^4, \\ [\Delta(\alpha_{3m-2})] &= [\Delta(\alpha_{3m-4})] \times 1^6 \cdot 2 \\ [\Delta(\alpha_{3m-1})] &= [\Delta(\alpha_2)] \times 1^{10(m-1)} \cdot 2^{m-1} = 1^{10m-6} \cdot 2^{m-1} \\ [\Delta(\alpha_{3m})] &= 1^{10m-1} \cdot 2^{m-1} \\ [\Delta(\alpha_{3m-2})] &= 1^{10m-10} \cdot 2^{m-1} \end{aligned}$$

$$\begin{aligned} \alpha_{3m} &= m + 1mm - 1, m^3, m^3 \\ &= kkk - 1, k^2k - 1, k^2k - 1 \\ &\oplus (m - k + 1)(m - k)(m - k), (m - k)^2(m - k + 1), (m - k)^2(m - k + 1) \\ &= k + 1k - 1k, k^3, k^3 \\ &\oplus (m - k + 1)(m - k)(m - k - 1), (m - k)^3, (m - k)^3 \\ &= 2(k + 1kk - 1, k^3, k^3) \\ &\oplus (m - 2k - 1)(m - 2k)(m - 2k + 1), (m - 2k)^3, (m - 2k)^3 \\ \alpha_{3m} &= \alpha_{3k-1} \oplus \alpha_{3(m-k)+1} \quad : 9 \quad (k = 1, \dots, m) \\ &= \alpha_{3k} \oplus \alpha_{3(m-k)} \quad : 1 \quad (k = 1, \dots, m - 1) \\ &= 2\alpha_{3k} \oplus \alpha_{3(m-2k)} \quad : 1 \quad (k = 1, \dots, m - 1) \\ \alpha_{3m-1} &= mmm - 1, mmm - 1, mmm - 1 \\ &= kk - 1k - 1, kk - 1k - 1, kk - 1k - 1 \\ &\oplus (m - k)(m - k + 1)(m - k), (m - k)(m - k + 1)(m - k), \dots \\ &= k + 1kk - 1, k^3, k^3 \\ &\oplus (m - k - 1)(m - k)(m - k), (m - k)(m - k)(m - k - 1), \dots \\ &= 2(kkk - 1, kkk - 1, kkk - 1) \\ &\oplus (m - 2k)(m - 2k)(m - 2k + 1), (m - 2k)(m - 2k)(m - 2k + 1), \dots \\ \alpha_{3m-1} &= \alpha_{3k-2}(= k, k - 1, k - 1; \dots) \oplus \alpha_{3(m-k)+1} \quad : 4 \quad (k = 1, \dots, m) \\ &= \alpha_{3k} \oplus \alpha_{3(m-k)-1} \quad : 6 \quad (k = 1, \dots, m - 1) \\ &= 2\alpha_{3k-1} \oplus \alpha_{3(m-2k)+1} \quad : 1 \quad (k = 1, \dots, m - 1) \end{aligned}$$

$$\begin{aligned}
\alpha_{3m-2} &= mm - 1m - 1, mm - 1m - 1, mm - 1m - 1 \\
&= kkk - 1, kkk - 1, kkk - 1 \\
&\oplus (m-k)(m-k-1)(m-k), (m-k)(m-k-1)(m-k), \dots \\
&= k + 1kk - 1, k^3, k^3 \\
&\oplus (m-k-1)(m-k-1)(m-k), (m-k)(m-k-1)(m-k-1), \dots \\
&= 2(kk - 1k - 1, kk - 1k - 1, kk - 1k - 1) \\
&\oplus (m-2k)(m-2k+1)(m-2k+1), (m-2k)(m-2k+1)(m-2k+1), \dots \\
\alpha_{3m-2} &= \alpha_{3k-1} (= k, k-1, k-1; \dots) \oplus \alpha_{3(m-k)-1} & : 4 & (k=1, \dots, m-1) \\
&= \alpha_{3k} \oplus \alpha_{3(m-k)-2} & : 6 & (k=1, \dots, m-1) \\
&= 2\alpha_{3k-2} \oplus \alpha_{3(m-2k)+2} & : 1 & (k=1, \dots, m-1)
\end{aligned}$$

The analysis of the other minimal series

$$\begin{aligned}
\beta_{4m,2} &= (2m+1)(2m-1), m^4, m^4 & \beta_{4,2} &= H_4 \\
\beta_{4m,4} &= (2m)^2, m^4, (m+1)m^2(m-1) & \beta_{4,4} &= EO_4 \\
\beta_{4m\pm 1} &= (2m)(2m\pm 1), (m\pm 1)m^3, (m\pm 1)m^3 & \beta_5 &= C_5, \beta_3 = H_3 \\
\beta_{4m+2} &= (2m+1)^2, (m+1)^2m^2, (m+1)^2m^2 \\
\gamma_{6m,2} &= (3m+1)(3m-1), (2m)^3, m^6 & \gamma_{6,2} &= D_6 = X_6 \\
\gamma_{6m,3} &= (3m)^2, (2m+1)(2m)(2m-1), m^6 & \gamma_{6,3} &= EO_6 \\
\gamma_{6m,6} &= (3m)^2, (2m)^3, (m+1)m^4(m-1) \\
\gamma_{6m\pm 1} &= (3m)(3m\pm 1), (2m)^2(2m\pm 1), m^5(m\pm 1) & \gamma_5 &= EO_5 \\
\gamma_{6m\pm 2} &= (3m\pm 1)(3m\pm 1), (2m)(2m\pm 1)^2, m^4(m\pm 1)^2 & \gamma_4 &= EO_4 \\
\gamma_{6m+3} &= (3m+2)(3m+1), (2m+1)^3, (m+1)^3m^3 & \gamma_3 &= H_3
\end{aligned}$$

and general  $P_{p+1,n}$  will be left to the reader as an exercise.

15.9.15. *Relation between series.* We have studied the following sets of families of spectral types of Fuchsian differential equations which are closed under the irreducible subquotients in the Grothendieck group.

$\{H_n\}$	(hypergeometric family)	
$\{P_n\}$	(Jordan-Pochhammer series)	
$\{A_n = EO_n\}$	(even/odd family)	
$\{B_n, C_n, H_n\}$	(3 singular points)	
$\{C_n, H_n\}$	(3 singular points)	
$\{D_n, E_n, H_n\}$	(3 singular points)	
$\{F_n, G_{2m}, H_n\}$	(3 singular points)	
$\{I_n, H_n\}$	(4 singular points)	
$\{J_n, H_n\}$	(4 singular points)	
$\{K_n, P_n\}$	( $\lfloor \frac{n+5}{2} \rfloor$ singular points)	
$\{L_{2m+1}, K_n, P_n\}$	( $m+2$ singular points)	
$\{M_n, P_n\}$	( $\lfloor \frac{n+5}{2} \rfloor$ singular points)	$\supset \{M_{2m+1}, P_n\}$
$\{N_n, M_n, P_n\}$	( $\lfloor \frac{n+3}{2} \rfloor$ singular points)	$\supset \{N_{2m+1}, M_n \cdot P_n\}$
$\{P_{4,n} = \delta_n\}$	(4 effective parameters)	

$\{\alpha_n\}$  (6 effective parameters and 3 singular points)

Yokoyama classified  $\mathbf{m} = (m_{j,\nu})_{\substack{0 \leq j \leq p \\ 1 \leq \nu \leq n_j}} \in \mathcal{P}_{p+1}$  such that

$$(15.44) \quad \mathbf{m} \text{ is irreducibly realizable,}$$

$$(15.45) \quad m_{0,1} + \cdots + m_{p-1,1} = (p-1) \text{ ord } \mathbf{m} \quad (\mathbf{m} \text{ is of Okubo type),}$$

$$(15.46) \quad m_{j,\nu} = 1 \quad (0 \leq j \leq p-1, 2 \leq \nu \leq n_j).$$

The tuple  $\mathbf{m}$  satisfying the above conditions is in the following list given by [Yo, Theorem 2] (cf. [Ro]).

Yokoyama	type	order	p+1	tuple of partitions
$I_n$	$H_n$	$n$	3	$1^n, n-11, 1^n$
$I_n^*$	$P_n$	$n$	$n+1$	$n-11, n-11, \dots, n-11$
$II_n$	$B_{2n}$	$2n$	3	$n1^n, n1^n, nn-11$
$II_n^*$	$I_{2n}$	$2n$	4	$n1^n, n+11^{n-1}, 2n-11, nn$
$III_n$	$B_{2n+1}$	$2n+1$	3	$n1^{n+1}, n+11^n, nn1$
$III_n^*$	$I_{2n+1}$	$2n+1$	4	$n+11^n, n+11^n, (2n)1, n+1n$
IV	$F_6$	6	3	$21111, 411, 222$
IV*	$N_6$	6	4	$411, 411, 411, 42$

**15.10. Appell's hypergeometric functions.** First we recall the Appell hypergeometric functions.

$$(15.47) \quad F_1(\alpha; \beta, \beta'; \gamma; x, y) = \sum_{m,n=0}^{\infty} \frac{(\alpha)_{m+n}(\beta)_m(\beta')_n}{(\gamma)_{m+n}m!n!} x^m y^n,$$

$$(15.48) \quad F_2(\alpha; \beta, \beta'; \gamma, \gamma'; x, y) = \sum_{m,n=0}^{\infty} \frac{(\alpha)_{m+n}(\beta)_m(\beta')_n}{(\gamma)_m(\gamma')_n m!n!} x^m y^n,$$

$$(15.49) \quad F_3(\alpha, \alpha'; \beta, \beta'; \gamma; x, y) = \sum_{m,n=0}^{\infty} \frac{(\alpha)_m(\alpha')_n(\beta)_m(\beta')_n}{(\gamma)_{m+n}m!n!} x^m y^n,$$

$$(15.50) \quad F_4(\alpha; \beta; \gamma, \gamma'; x, y) = \sum_{m,n=0}^{\infty} \frac{(\alpha)_{m+n}(\beta)_{m+n}}{(\gamma)_m(\gamma')_n m!n!} x^m y^n.$$

They satisfy the following equations

$$(15.51) \quad \left( (\vartheta_x + \vartheta_y + \alpha)(\vartheta_x + \beta) - \partial_x(\vartheta_x + \vartheta_y + \gamma - 1) \right) F_1 = 0,$$

$$(15.52) \quad \left( (\vartheta_x + \vartheta_y + \alpha)(\vartheta_x + \beta) - \partial_x(\vartheta_x + \gamma - 1) \right) F_2 = 0,$$

$$(15.53) \quad \left( (\vartheta_x + \alpha)(\vartheta_x + \beta) - \partial_x(\vartheta_x + \vartheta_y + \gamma - 1) \right) F_3 = 0,$$

$$(15.54) \quad \left( (\vartheta_x + \vartheta_y + \alpha)(\vartheta_x + \vartheta_y + \beta) - \partial_x(\vartheta_x + \gamma - 1) \right) F_4 = 0.$$

Similar equations hold under the symmetry  $x \leftrightarrow y$  with  $(\alpha, \beta, \gamma) \leftrightarrow (\alpha', \beta', \gamma')$ .

15.10.1. *Appell's  $F_1$* . First we examine  $F_1$ . Put

$$\begin{aligned} u(x, y) &:= \int_0^x t^\alpha (1-t)^\beta (y-t)^{\gamma-1} (x-t)^{\lambda-1} dt \quad (t = xs) \\ &= \int_0^1 x^{\alpha+\lambda+1} s^\alpha (1-xs)^\beta (y-xs)^{\gamma-1} (1-s)^{\lambda-1} ds \\ &= x^{\alpha+\lambda} y^{\gamma-1} \int_0^1 s^\alpha (1-s)^{\lambda-1} (1-xs)^\beta \left(1 - \frac{y}{x}s\right)^{\gamma-1} ds, \\ h_x &:= x^\alpha (x-1)^\beta (x-y)^{\gamma-1}. \end{aligned}$$

Since the left ideal of  $\overline{W}[x, y]$  is not necessarily generated by a single element, we want to have good generators of  $\text{RAd}(\partial_x^{-\lambda}) \circ \text{RAd}(h_x)(W[x, y]\partial_x + W[x, y]\partial_y)$  and we have

$$\begin{aligned} P &:= \text{Ad}(h_x)\partial_x = \partial_x - \frac{\alpha}{x} - \frac{\beta}{x-1} - \frac{\gamma-1}{x-y}, \\ Q &:= \text{Ad}(h_x)\partial_y = \partial_y + \frac{\gamma-1}{x-y}, \\ R &:= xP + yQ = x\partial_x + y\partial_y - (\alpha + \gamma - 1) - \frac{\beta x}{x-1}, \\ S &:= \partial_x(x-1)R = (\vartheta_x + 1)(\vartheta_x + \vartheta_y - \alpha - \beta - \gamma + 1) - \partial_x(\vartheta_x + \vartheta_y - \alpha - \gamma + 1) \\ T &:= \partial_x^{-\lambda} \circ S \circ \partial_x^\lambda \\ &= (\vartheta_x - \lambda + 1)(\vartheta_x + \vartheta_y - \alpha - \beta - \gamma - \lambda + 1) - \partial_x(\vartheta_x + \vartheta_y - \alpha - \gamma - \lambda + 1) \end{aligned}$$

with

$$a = -\alpha - \beta - \gamma - \lambda + 1, \quad b = 1 - \lambda, \quad c = 2 - \alpha - \gamma - \lambda.$$

This calculation shows the equation  $Tu(x, y) = 0$  and we have a similar equation by changing  $(x, y, \gamma, \lambda) \mapsto (y, x, \lambda, \gamma)$ . Note that  $TF_1(a; b, b'; c; x, y) = 0$  with  $b' = 1 - \gamma$ .

Putting

$$\begin{aligned} v(x, z) &= I_{0,x}^\mu (x^\alpha (1-x)^\beta (1-zx)^{\gamma-1}) \\ &= \int_0^x t^\alpha (1-t)^\beta (1-zt)^{\gamma-1} (x-t)^{\mu-1} dt \\ &= x^{\alpha+\mu} \int_0^1 s^\alpha (1-xs)^\beta (1-xzs)^{\gamma-1} (1-s)^{\mu-1} ds, \end{aligned}$$

we have

$$\begin{aligned} u(x, y) &= y^{\gamma-1} v(x, \frac{1}{y}), \\ t^\alpha (1-t)^\beta (1-zt)^{\gamma-1} &= \sum_{m,n=0}^{\infty} \frac{(-\beta)_m (1-\gamma)_n}{m!n!} t^{\alpha+m+n} z^n, \\ v(x, z) &= \sum_{m,n=0}^{\infty} \frac{\Gamma(\alpha+m+n+1)(-\beta)_m (1-\gamma)_n}{\Gamma(\alpha+\mu+m+n+1)m!n!} x^{\alpha+\gamma+m+n} z^n \\ &= x^{\alpha+\mu} \frac{\Gamma(\alpha+1)}{\Gamma(\alpha+\mu+1)} \sum_{m,n=0}^{\infty} \frac{(\alpha+1)_{m+n} (-\beta)_m (1-\gamma)_n}{(\alpha+\mu+1)_{m+n} m!n!} x^{m+n} z^n \\ &= x^{\alpha+\mu} \frac{\Gamma(\alpha+1)}{\Gamma(\alpha+\mu+1)} F_1(\alpha+1; -\beta, 1-\gamma; \alpha+\mu+1; x, xz). \end{aligned}$$

Using a versal addition to get the Kummer equation, we introduce the functions

$$\begin{aligned} v_c(x, y) &:= \int_0^x t^\alpha (1-ct)^{\frac{\beta}{c}} (y-t)^{\gamma-1} (x-t)^{\lambda-1}, \\ h_{c,x} &:= x^\alpha (1-cx)^{\frac{\beta}{c}} (x-y)^{\gamma-1}. \end{aligned}$$

Then we have

$$\begin{aligned} R &:= \text{Ad}(h_{c,x})(\vartheta_x + \vartheta_y) = \vartheta_x + \vartheta_y - (\alpha + \gamma - 1) + \frac{\beta x}{1-cx}, \\ S &:= \partial_x(1-cx)R \\ &= (\vartheta_x + 1)(\beta - c(\vartheta_x + \vartheta_y - \alpha - \gamma + 1)) + \partial_x(\vartheta_x + \vartheta_y - \alpha - \gamma + 1), \\ T &:= \text{Ad}(\partial^{-\lambda})R \\ &= (\vartheta_x - \lambda + 1)(\beta - c(\vartheta_x + \vartheta_y - \lambda - \alpha - \gamma + 1)) + \partial_x(\vartheta_x + \vartheta_y - \lambda - \alpha - \gamma + 1) \end{aligned}$$

and hence  $u_c(x, y)$  satisfies the differential equation

$$\begin{aligned} &\left( x(1-cx)\partial_x^2 + y(1-cx)\partial_x\partial_y \right. \\ &\quad + (2 - \alpha - \gamma - \lambda + (\beta + \lambda - 2 + c(\alpha + \gamma + \lambda - 1))x)\partial_x + (\lambda - 1)\partial_y \\ &\quad \left. - (\lambda - 1)(\beta + c(\alpha + \gamma + \lambda - 1)) \right) u = 0. \end{aligned}$$

15.10.2. *Appell's  $F_4$ .* To examine  $F_4$  we consider the function

$$v(x, y) := \int_{\Delta} s^{\lambda_1} t^{\lambda_2} (st - s - t)^{\lambda_3} (1 - sx - ty)^{\mu} ds dt$$

and the transformation

$$(15.55) \quad J_x^\mu(u)(x) := \int_{\Delta} u(t_1, \dots, t_n) (1 - t_1 x_1 - \dots - t_n x_n)^\mu dt_1 \cdots dt_n$$

for function  $u(x_1, \dots, x_n)$ . For example the region  $\Delta$  is given by

$$v(x, y) = \int_{s \leq 0, t \leq 0} s^{\lambda_1} t^{\lambda_2} (st - s - t)^{\lambda_3} (1 - sx - ty)^{\mu} ds dt.$$

Putting  $s \mapsto s^{-1}$ ,  $t \mapsto t^{-1}$  and  $|x| + |y| < c < \frac{1}{2}$ , Aomoto [Ao] shows

$$(15.56) \quad \begin{aligned} &\int_{c-\infty i}^{c+\infty i} \int_{c-\infty i}^{c+\infty i} s^{-\gamma} t^{-\gamma'} (1-s-t)^{\gamma+\gamma'-\alpha-2} \left(1 - \frac{x}{s} - \frac{y}{t}\right)^{-\beta} ds dt \\ &= -\frac{4\pi^2 \Gamma(\alpha)}{\Gamma(\gamma)\Gamma(\gamma')\Gamma(\alpha - \gamma - \gamma' + 2)} F_4(\alpha; \beta; \gamma, \gamma'; x, y), \end{aligned}$$

which follows from the integral formula

$$(15.57) \quad \begin{aligned} &\frac{1}{(2\pi i)^n} \int_{\frac{1}{n+1}-\infty i}^{\frac{1}{n+1}+\infty i} \cdots \int_{\frac{1}{n+1}-\infty i}^{\frac{1}{n+1}+\infty i} \prod_{j=1}^n t_j^{-\alpha_j} \left(1 - \sum_{j=1}^n t_j\right)^{-\alpha_{n+1}} dt_1 \cdots dt_n \\ &= \frac{\Gamma(\sum_{j=1}^{n+1} \alpha_j - n)}{\prod_{j=1}^{n+1} \Gamma(\alpha_j)}. \end{aligned}$$

Since

$$J_x^\mu(u) = J_x^{\mu-1}(u) - \sum x_\nu J_x^{\mu-1}(x_\nu u)$$

and

$$\begin{aligned} & \frac{d}{dt_i} (u(t)(1 - \sum t_\nu x_\nu)^\mu) \\ &= \frac{du}{dt_i}(t)(1 - \sum t_\nu x_\nu)^\mu - \mu u(t)x_i(1 - \sum t_\nu x_\nu)^{\mu-1}, \end{aligned}$$

we have

$$\begin{aligned} J_x^\mu(\partial_i u)(x) &= \mu x_i J_x^{\mu-1}(u)(x) \\ &= -x_i \int t_i^{-1} u(t) \frac{d}{dx_i} (1 - \sum x_\nu t_\nu)^\mu dt \\ &= -x_i \frac{d}{dx_i} J_x^\mu\left(\frac{u}{x_i}\right)(x), \\ J_x^\mu(\partial_i(x_i u)) &= -x_i \partial_i J_x^\mu(u), \\ J_x^\mu(\partial_i u) &= \mu x_i J_x^{\mu-1}(u) \\ &= \mu x_i J_x^\mu(u) + \mu x_i \sum x_\nu J_x^{\mu-1}(x_\nu u) \\ &= \mu x_i J_x^\mu(u) + x_i \sum J_x^\mu(\partial_\nu(x_\nu u)) \\ &= \mu x_i J_x^\mu(u) - x_i \sum x_\nu \partial_\nu J_x^\mu(u) \end{aligned}$$

and therefore

$$(15.58) \quad J_x^\mu(x_i \partial_i u) = (-1 - x_i \partial_i) J_x^\mu(u),$$

$$(15.59) \quad J_x^\mu(\partial_i u) = x_i (\mu - \sum x_\nu \partial_\nu) J_x^\mu(u).$$

Thus we have

**Proposition 15.1.** *For a differential operator*

$$(15.60) \quad P = \sum_{\substack{\alpha=(\alpha_1, \dots, \alpha_n) \in \mathbb{Z}_{\geq 0}^n \\ \beta=(\beta_1, \dots, \beta_n) \in \mathbb{Z}_{\geq 0}^n}} c_{\alpha, \beta} \partial_1^{\alpha_1} \dots \partial_n^{\alpha_n} \vartheta_1^{\beta_1} \dots \vartheta_n^{\beta_n},$$

we have

$$(15.61) \quad \begin{aligned} J_x^\mu(Pu(x)) &= J_x^\mu(P) J_x^\mu(u(x)), \\ J_x^\mu(P) &:= \sum_{\alpha, \beta} c_{\alpha, \beta} \prod_{k=1}^n (x_k (\mu - \sum_{\nu=1}^n \vartheta_\nu))^{\alpha_k} \prod_{k=1}^n (-\vartheta_k - 1)^{\beta_k}. \end{aligned}$$

Using this proposition, we obtain the system of differential equations satisfied by  $J_x^\mu(u)$  from that satisfied by  $u(x)$ . Denoting the Laplace transform of the variable  $x = (x_1, \dots, x_n)$  by  $L_x$  (cf. Definition 2.1), we have

$$(15.62) \quad J_x^\mu L_x^{-1}(\vartheta_i) = \vartheta_i, \quad J_x^\mu L_x^{-1}(x_i) = x_i \left( \mu - \sum_{\nu=1}^n \vartheta_\nu \right).$$

We have

$$\begin{aligned} \text{Ad}(x^{\lambda_1} y^{\lambda_2} (xy - x - y)^{\lambda_3}) \partial_x &= \partial_x - \frac{\lambda_1}{x} - \frac{\lambda_3(y-1)}{xy - x - y}, \\ \text{Ad}(x^{\lambda_1} y^{\lambda_2} (xy - x - y)^{\lambda_3}) \partial_y &= \partial_y - \frac{\lambda_2}{y} - \frac{\lambda_3(x-1)}{xy - x - y}, \\ \text{Ad}(x^{\lambda_1} y^{\lambda_2} (xy - x - y)^{\lambda_3}) (x(x-1) \partial_x) & \\ &= x(x-1) \partial_x - \lambda_1(x-1) - \frac{\lambda_3(x-1)(xy-x)}{xy-x-y}, \end{aligned}$$

$$\begin{aligned}
& \text{Ad}(x^{\lambda_1}y^{\lambda_2}(xy-x-y)^{\lambda_3})(x(x-1)\partial_x-y\partial_y) \\
& \quad = x(x-1)\partial_x-y\partial_y-\lambda_1(x-1)-\lambda_2-\lambda_3(x-1) \\
& \quad = x\vartheta_x-\vartheta_x-\vartheta_y-(\lambda_1+\lambda_3)x+\lambda_1-\lambda_2+\lambda_3, \\
(15.63) \quad & \partial_x \text{Ad}(x^{\lambda_1}y^{\lambda_2}(xy-x-y)^{\lambda_3})(x(x-1)\partial_x-y\partial_y) \\
& \quad = \partial_x x(\vartheta_x-\lambda_1-\lambda_3)-\partial_x(\vartheta_x+\vartheta_y-\lambda_1+\lambda_2-\lambda_3)
\end{aligned}$$

and

$$\begin{aligned}
& J_{x,y}^\mu(\partial_x x(\vartheta_x-\lambda_1-\lambda_3)-\partial_x(\vartheta_x+\vartheta_y-\lambda_1+\lambda_2-\lambda_3)) \\
& \quad = \vartheta_x(1+\vartheta_x+\lambda_1+\lambda_3)-x(-\mu+\vartheta_x+\vartheta_y)(2+\vartheta_x+\vartheta_y+\lambda_1-\lambda_2+\lambda_3).
\end{aligned}$$

Putting

$$T := (\vartheta_x + \vartheta_y - \mu)(\vartheta_x + \vartheta_y + \lambda_1 - \lambda_2 + \lambda_3 + 2) - \partial_x(\vartheta_x + \lambda_1 + \lambda_3 + 1)$$

with

$$\alpha = -\mu, \quad \beta = \lambda_1 - \lambda_2 + \lambda_3 + 2, \quad \gamma = \lambda_1 + \lambda_3 + 2,$$

we have  $Tv(x, y) = 0$  and moreover it satisfies a similar equation by replacing  $(x, y, \lambda_1, \lambda_3, \gamma)$  by  $(y, x, \lambda_3, \lambda_1, \gamma')$ . Hence  $v(x, y)$  is a solution of the system of differential equations satisfied by  $F_4(\alpha; \beta; \gamma; \gamma'; x, y)$ .

In the same way we have

$$\begin{aligned}
& \text{Ad}(x^{\beta-1}y^{\beta'-1}(1-x-y)^{\gamma-\beta-\beta'-1})\vartheta_x = \vartheta_x - \beta + 1 + \frac{(\gamma - \beta - \beta' - 1)x}{1 - x - y}, \\
(15.64) \quad & \text{Ad}(x^{\beta-1}y^{\beta'-1}(1-x-y)^{\gamma-\beta-\beta'-1})(\vartheta_x - x(\vartheta_x + \vartheta_y)) \\
& \quad = \vartheta_x - x(\vartheta_x + \vartheta_y) - \beta + 1 + (\gamma - 3)x \\
& \quad = (\vartheta_x - \beta + 1) - x(\vartheta_x + \vartheta_y - \gamma + 3), \\
& J_{x,y}^\mu(\partial_x(\vartheta_x - \beta + 1) - \partial_x x(\vartheta_x + \vartheta_y - \gamma + 3)) \\
& \quad = x(-\vartheta_x - \vartheta_y + \mu)(-\vartheta_x - \beta) + \vartheta_x(-2 - \vartheta_x - \vartheta_y - \gamma + 3) \\
& \quad = x((\vartheta_x + \vartheta_y - \mu)(\vartheta_x + \beta) - \partial_x(\vartheta_x + \vartheta_y + \gamma - 1)).
\end{aligned}$$

which is a differential operator killing  $F_1(\alpha; \beta; \beta'; \gamma; x, y)$  by putting  $\mu = -\alpha$  and in fact we have

$$\begin{aligned}
& \iint_{\substack{s \geq 0, t \geq 0 \\ 1-s-t \geq 0}} s^{\beta-1}t^{\beta'-1}(1-s-t)^{\gamma-\beta-\beta'-1}(1-sx-ty)^{-\alpha} ds dt \\
& \quad = \iint_{\substack{s \geq 0, t \geq 0 \\ 1-s-t \geq 0}} \sum_{m, n=0}^{\infty} s^{\beta+m-1}t^{\beta'+n-1}(1-s-t)^{\gamma-\beta-\beta'-1} \frac{(\alpha)_{m+n}x^m y^n}{m!n!} ds dt \\
& \quad = \sum_{m, n=0}^{\infty} \frac{\Gamma(\beta+m)\Gamma(\beta'+n)\Gamma(\gamma-\beta-\beta')}{\Gamma(\gamma+m+n)} \cdot \frac{(\alpha)_{m+n}x^m y^n}{m!n!} \\
& \quad = \frac{\Gamma(\beta)\Gamma(\beta')\Gamma(\gamma-\beta-\beta')}{\Gamma(\gamma)} F_1(\alpha; \beta; \beta'; \gamma; x, y).
\end{aligned}$$

Here we use the formula

$$(15.65) \quad \iint_{\substack{s \geq 0, t \geq 0 \\ 1-s-t \geq 0}} s^{\lambda_1-1}t^{\lambda_2-1}(1-s-t)^{\lambda_3-1} ds dt = \frac{\Gamma(\lambda_1)\Gamma(\lambda_2)\Gamma(\lambda_3)}{\Gamma(\lambda_1+\lambda_2+\lambda_3)}.$$



15.10.3. *Appell's  $F_3$* . Since

$$\begin{aligned} T_3 &:= J_y^{-\alpha'} x^{-1} J_x^{-\alpha} (\partial_x (\vartheta_x - \beta + 1) - \partial_x x (\vartheta_x + \vartheta_y - \gamma + 3)) \\ &= J_y^{-\alpha'} ((-\vartheta_x - \alpha)(-\vartheta_x - \beta) + \partial_x (-\vartheta_x + \vartheta_y - \gamma + 2)) \\ &= (\vartheta_x + \alpha)(\vartheta_x + \beta) - \partial_x (\vartheta_x + \vartheta_y + \gamma - 1) \end{aligned}$$

with (15.64), the operator  $T_3$  kills the function

$$\begin{aligned} &\iint_{\substack{s \geq 0, t \geq 0 \\ 1-s-t \geq 0}} s^{\beta-1} t^{\beta'-1} (1-s-t)^{\gamma-\beta-\beta'-1} (1-xs)^{-\alpha} (1-yt)^{-\alpha'} ds dt \\ &= \iint_{\substack{s \geq 0, t \geq 0 \\ 1-s-t \geq 0}} \sum_{m, n=0}^{\infty} s^{\beta+m-1} t^{\beta'+n-1} (1-s-t)^{\gamma-\beta-\beta'-1} \frac{(\alpha)_m (\alpha')_n x^m y^n}{m! n!} ds dt \\ &= \sum_{m, n=0}^{\infty} \frac{\Gamma(\beta+m) \Gamma(\beta'+n) \Gamma(\gamma-\beta-\beta') (\alpha)_m (\alpha')_n}{\Gamma(\gamma+m+n) m! n!} x^m y^n \\ &= \frac{\Gamma(\beta) \Gamma(\beta') \Gamma(\gamma-\beta-\beta')}{\Gamma(\gamma)} F_3(\alpha, \alpha'; \beta, \beta'; \gamma; x, y). \end{aligned}$$

Moreover since

$$\begin{aligned} T'_3 &:= \text{Ad}(\partial_x^{-\mu}) \text{Ad}(\partial_y^{-\mu'}) ((\vartheta_x + 1)(\vartheta_x - \lambda_1 - \lambda_3) - \partial_x (\vartheta_x + \vartheta_y - \lambda_1 + \lambda_2 - \lambda_3)) \\ &= (\vartheta_x + 1 - \mu)(\vartheta_x - \lambda_1 - \lambda_3 - \mu) - \partial_x (\vartheta_x + \vartheta_y - \lambda_1 + \lambda_2 - \lambda_3 - \mu - \mu') \end{aligned}$$

with (15.63) and

$$\alpha = -\lambda_1 - \lambda_3 - \mu, \quad \beta = 1 - \mu, \quad \gamma = -\lambda_1 + \lambda_2 - \lambda_3 - \mu - \mu' + 1,$$

the function

$$(15.66) \quad u_3(x, y) := \int_{-\infty}^y \int_{-\infty}^x s^{\lambda_1} t^{\lambda_2} (st - s - t)^{\lambda_3} (x-s)^{\mu-1} (y-t)^{\mu'-1} ds dt$$

satisfies  $T'_3 u_3(x, y) = 0$ . Hence  $u_3(x, y)$  is a solution of the system of the equations that  $F_3(\alpha, \alpha'; \beta, \beta'; \gamma; x, y)$  satisfies.

15.10.4. *Appell's  $F_2$* . Since

$$\begin{aligned} &\partial_x \text{Ad}(x^{\lambda_1-1} (1-x^{\lambda_2-1})) x(1-x) \partial_x \\ &= \partial_x x(1-x) \partial_x - (\lambda_1 - 1) \partial_x + \partial_x (\lambda_1 + \lambda_2 - 2)x \\ &= \partial_x x(-\vartheta_x + \lambda_1 + \lambda_2 - 2) + \partial_x (\vartheta - \lambda_1 + 1) \end{aligned}$$

and

$$\begin{aligned} T_2 &:= J_{x,y}^{\mu} (\partial_x x (-\vartheta_x + \lambda_1 + \lambda_2 - 2) + \partial_x (\vartheta_x - \lambda_1 + 1)) \\ &= -\vartheta_x (\vartheta_x + 1 + \lambda_1 + \lambda_2 - 2) + x(\mu - \vartheta_x - \vartheta_y) (-1 - \vartheta_x - \lambda_1 + 1) \\ &= x \left( (\vartheta_x + \lambda_1)(\vartheta_x + \vartheta_y - \mu) - \partial_x (\vartheta_x + \lambda_1 + \lambda_2 - 1) \right) \end{aligned}$$

with

$$\alpha = -\mu, \quad \beta = \lambda_1, \quad \gamma = \lambda_1 + \lambda_2,$$

the function

$$\begin{aligned}
 u_2(x, y) &:= \int_0^1 \int_0^1 s^{\lambda_1-1} (1-s)^{\lambda_2-1} t^{\lambda'_1-1} (1-t)^{\lambda'_2-1} (1-xs-yt)^\mu ds dt \\
 &= \int_0^1 \int_0^1 \sum_{m, n=0}^{\infty} s^{\lambda_1+m-1} (1-s)^{\lambda_2-1} t^{\lambda'_1+n-1} (1-t)^{\lambda'_2-1} \frac{(-\mu)_{m+n}}{m!n!} x^m y^n ds dt \\
 &= \sum_{m, n=0}^{\infty} \frac{\Gamma(\lambda_1+m)\Gamma(\lambda_2)}{\Gamma(\lambda_1+\lambda_2+m)} \frac{\Gamma(\lambda'_1+n)\Gamma(\lambda'_2)}{\Gamma(\lambda'_1+\lambda'_2+n)} \frac{(-\mu)_{m+n}}{m!n!} x^m y^n \\
 &= \frac{\Gamma(\lambda_1)\Gamma(\lambda_2)\Gamma(\lambda'_1)\Gamma(\lambda'_2)}{\Gamma(\lambda_1+\lambda_2)\Gamma(\lambda'_1+\lambda'_2)} \sum_{m, n=0}^{\infty} \frac{(\lambda_1)_m (\lambda'_1)_n (-\mu)_{m+n}}{(\lambda_1+\lambda_2)_m (\lambda'_1+\lambda'_2)_n m!n!} x^m y^n
 \end{aligned}$$

is a solution of the equation  $T_2 u = 0$  that  $F_2(\alpha; \beta, \beta'; \gamma, \gamma'; x, y)$  satisfies.

Note that the operator  $\tilde{T}_3$  transformed from  $T_3$  by the coordinate transformation  $(x, y) \mapsto (\frac{1}{x}, \frac{1}{y})$  equals

$$\begin{aligned}
 \tilde{T}_3 &= (-\vartheta_x + \alpha)(-\vartheta_x + \beta) - x(-\vartheta_x)(-\vartheta_x - \vartheta_y + \gamma - 1) \\
 &= (\vartheta_x - \alpha)(\vartheta_x - \beta) - x\vartheta_x(\vartheta_x + \vartheta_y - \gamma + 1)
 \end{aligned}$$

and the operator

$$\text{Ad}(x^{-\alpha}y^{-\alpha'})\tilde{T}_3 = \vartheta_x(\vartheta_x + \alpha - \beta) - x(\vartheta_x + \alpha)(\vartheta_x + \vartheta_y + \alpha + \alpha' - \gamma + 1)$$

together with the operator obtained by the transpositions  $x \leftrightarrow y$ ,  $\alpha \leftrightarrow \alpha'$  and  $\beta \leftrightarrow \beta'$  defines the system of the equations satisfied by the functions

$$(15.67) \quad \begin{cases} F_2(\alpha + \alpha' - \gamma + 1; \alpha, \alpha'; \alpha - \beta + 1, \alpha' - \beta' + 1; x, y), \\ x^{-\alpha'}y^{-\alpha'} F_3(\alpha, \alpha'; \beta, \beta'; \gamma; \frac{1}{x}, \frac{1}{y}), \end{cases}$$

which also follows from the integral representation (15.66) with the transformation  $(x, y, s, t) \mapsto (\frac{1}{x}, \frac{1}{y}, \frac{1}{s}, \frac{1}{t})$ .

**15.11. Okubo and Risa/Asir.** Most of our results in this paper are constructible and they can be explicitly calculated and implemented in computer programs.

The computer program `okubo` [O8] written by the author handles combinatorial calculations in this paper related to tuples of partitions. It generates basic tuples (cf. §15.1) and rigid tuples (cf. §15.2), calculates the reductions originated by Katz and Yokoyama, the position of accessory parameters in the universal model (cf. Theorem 8.13 iv)) and direct decompositions etc.

The author presented Theorem 14.6 in the case when  $p = 3$  as a conjecture in the fall of 2007, which was proved in May in 2008 by a completely different way from the proof given in §14.1, which is a generalization of the original proof of Gauss's summation formula of the hypergeometric series explained in §14.3. The original proof of Theorem 14.6 in the case when  $p = 3$  was reduced to the combinatorial equality (14.16). The author verified (14.16) by `okubo` and got the concrete connection coefficients for the rigid tuples  $\mathbf{m}$  satisfying  $\text{ord } \mathbf{m} \leq 40$ . Under these conditions ( $\text{ord } \mathbf{m} \leq 40$ ,  $p = 3$ ,  $m_{0,n_0} = m_{1,n_1} = 1$ ) there are 4,111,704 independent connection coefficients modulo obvious symmetries and it took about one day to get all of them by a personal computer with `okubo`.

Several operations on differential operators such as additions and middle convolutions defined in §2 can be calculated by a computer algebra and the author wrote a program for their results under `Risa/Asir`, which gives a reduction procedure of the operators (cf. Definition 7.11), integral representations and series expansions of

the solutions (cf. Theorem 10.1), connection formulas (cf. Theorem 14.5), differential operators (cf. Theorem 8.13 iv)), the condition of their reducibility (cf. Corollary 12.12 i)), recurrence relations (cf. Theorem 13.3 ii)) etc. for any given spectral type or Riemann scheme (1.10) and displays the results using  $\text{\TeX}$ . This program for Risa/Asir written by author contains many useful functions calculating rational functions, Weyl algebra and matrices. These programs can be obtained from

<http://www.math.kobe-u.ac.jp/Asir/asir.html>  
<ftp://akagi.ms.u-tokyo.ac.jp/pub/math/muldif>  
<ftp://akagi.ms.u-tokyo.ac.jp/pub/math/okubo>.

## 16. FURTHER PROBLEMS

**16.1. Multiplicities of spectral parameters.** Suppose a Fuchsian differential equation and its middle convolution are given. Then we can analyze the corresponding transformation of a global structure of its local solution associated with an eigenvalue of the monodromy generator at a singular point if the eigenvalue is free of multiplicity.

When the multiplicity of the eigenvalue is larger than one, we have not a satisfactory result for the transformation (cf. Theorem 14.5). The value of a generalized connection coefficient defined by Definition 14.17 may be interesting. Is the procedure in Remark 14.19 always valid? In particular, is there a general result assuring Remark 14.19 (1) (cf. Remark 14.23)? Are the multiplicities of zeros of the generalized connection coefficients of a rigid Fuchsian differential equation free?

**16.2. Schlesinger canonical form.** Can we define a natural *universal* Fuchsian system of Schlesinger canonical form (2.74) with a given realizable spectral type? Here we recall Example 11.2.

Let  $P_{\mathbf{m}}$  be the universal operator in Theorem 8.13. Is there a natural system of Schlesinger canonical form which is isomorphic to the equation  $P_{\mathbf{m}}u = 0$  together with the explicit correspondence between them?

**16.3. Apparent singularities.** Katz [Kz] proved that any irreducible rigid local system is constructed from the trivial system by successive applications of middle convolutions and additions and it is proved in this paper that the system is realized by a single differential equation without an apparent singularity.

In general an irreducible local system cannot be realized by a single differential equation without an apparent singularity but it is realized by that with apparent singularities. Hence it is expected that there exist some natural operations of single differential equations with apparent singularities which correspond to middle convolutions of local systems or systems of Schlesinger canonical form.

The Fuchsian ordinary differential equation satisfied by an important special function often hasn't an apparent singularity even if the spectral type of the equation is not rigid. Can we understand the condition that a  $W(x)$ -module has a generator so that it satisfies a differential equation without an apparent singularity? Moreover it may be interesting to study the existing of contiguous relations among differential equations with fundamental spectral types which have no apparent singularity.

**16.4. Irregular singularities.** Our fractional operations defined in §2 give transformations of ordinary differential operators with polynomial coefficients, which have irregular singularities in general. The reduction of ordinary differential equations under these operations is a problem to be studied. Note that versal additions and middle convolutions construct such differential operators from the trivial equation.

A similar result as in this paper is obtained for certain classes of ordinary differential equations with irregular singularities (cf. [Hi]).

A “versal” path of integral in an integral representation of the solution and a “versal” connection coefficient and Stokes multiplier should be studied. Here “versal” means a natural expression corresponding to the versal addition.

We define a complete model with a given spectral type as follows. For simplicity we consider differential operators without singularities at the origin. For a realizable irreducible tuple of partitions  $\mathbf{m} = (m_{j,\nu})_{\substack{0 \leq j \leq p \\ 1 \leq \nu \leq n_j}}$  of a positive integer  $n$  Theorem 8.13 constructs the universal differential operator

$$(16.1) \quad P_{\mathbf{m}} = \prod_{j=1}^p (1 - c_j x)^n \cdot \frac{d^n}{dx^n} + \sum_{k=0}^{n-1} a_k(x, c, \lambda, g) \frac{d^k}{dx^k}$$

with the Riemann scheme

$$\left\{ \begin{array}{cccc} x = \infty & \frac{1}{c_1} & \cdots & \frac{1}{c_p} \\ [\lambda_{0,1}]_{(m_{0,1})} & [\lambda_{1,1}]_{(m_{1,1})} & \cdots & [\lambda_{p,1}]_{(m_{p,1})} \\ \vdots & \vdots & \vdots & \vdots \\ [\lambda_{0,n_0}]_{(m_{0,n_0})} & [\lambda_{1,n_1}]_{(m_{1,n_1})} & \cdots & [\lambda_{p,n_p}]_{(m_{p,n_p})} \end{array} \right\}$$

and the Fuchs relation

$$\sum_{j=0}^p \sum_{\nu=1}^{n_j} m_{j,\nu} \lambda_{j,\nu} = n - \frac{\text{idx } \mathbf{m}}{2}.$$

Here  $c = (c_0, \dots, c_p)$ ,  $\lambda = (\lambda_{j,\nu})$  and  $g = (g_1, \dots, g_N)$  are parameters. We have  $c_i c_j (c_i - c_j) \neq 0$  for  $0 \leq i < j \leq p$ . The parameters  $g_j$  are called accessory parameters and we have  $\text{idx } \mathbf{m} = 2 - 2N$ . We call the Zariski closure  $\overline{P}_{\mathbf{m}}$  of  $P_{\mathbf{m}}$  in  $W[x]$  the *complete model* of differential operators with the spectral type  $\mathbf{m}$ , whose dimension equals  $p + \sum_{j=0}^p n_j + N - 1$ . It is an interesting problem to analyze the complete model  $\overline{P}_{\mathbf{m}}$ .

When  $\mathbf{m} = 11, 11, 11$ , the complete model equals

$$(1 - c_1 x)^2 (1 - c_2 x)^2 \frac{d^2}{dx^2} - (1 - c_1 x)(1 - c_2 x)(a_{1,1} x + a_{1,0}) \frac{d}{dx} + a_{0,2} x^2 + a_{0,1} x + a_{0,0},$$

whose dimension equals 7. Any differential equation defined by the operator belonging to this complete model is transformed into a Gauss hypergeometric equation, a Kummer equation, an Hermite equation or an airy equation by a suitable gauge transformation and a coordinate transformation. A good understanding together with a certain completion of our operators is required even in this fundamental example. It is needless to say that the good understanding is important in the case when  $\mathbf{m}$  is fundamental.

**16.5. Special parameters.** Let  $P_{\mathbf{m}}$  be the universal operator of the form (16.1) for an irreducible tuple of partition  $\mathbf{m}$ . When a decomposition  $\mathbf{m} = \mathbf{m}' + \mathbf{m}''$  with realizable tuples of partitions  $\mathbf{m}'$  and  $\mathbf{m}''$  is given, Theorem 6.19 gives the values of the parameters of  $P_{\mathbf{m}}$  corresponding to the product  $P_{\mathbf{m}'} P_{\mathbf{m}''}$ . A  $W(x, \xi)$ -automorphism of  $P_{\mathbf{m}} u = 0$  gives a transformation of the parameters  $(\lambda, g)$ , which is a contiguous relation and called Schlesinger transformation in the case of systems of Schlesinger canonical form. How can we describe the values of the parameters obtained in this way and characterize their position in all the values of the parameters when the universal operator is reducible? In general they are not all even in a rigid differential equation. A direct decomposition  $32, 32, 32 = 12, 12, 12, 12 \oplus 2(10, 10, 10, 10)$  of a rigid tuples  $32, 32, 32, 32$  gives this example (cf. (12.65)).

Analyse the reducible differential equation with an irreducibly realizable spectral type. This is interesting even when  $\mathbf{m}$  is a rigid tuple. For example, describe the monodromy of its solutions.

Describe the characteristic exponents of the generalized Riemann scheme with an irreducibly realizable spectral type such that there exists a differential operator with the Riemann scheme which is outside the universal operator (cf. Example 7.5 and Remark 8.15). In particular, when the spectral type is not fundamental nor simply reducible, does there exist such a differential operator?

The classification of rigid and simply reducible spectral types coincides with that of indecomposable objects described in [MWZ, Theorem 2.4]. Is there some meaning in this coincidence?

Has the condition (8.28) a similar meaning in the case of Schlesinger canonical form? What condition on the spectral type does assure that the local system has a realization of Schlesinger canonical form?

Give the condition so that the monodromy group is finite. Give the condition so that the centralizer of the monodromy is the set of scalar multiplications.

Suppose  $\mathbf{m}$  is fundamental. Study the condition so that the connection coefficients is a quotient of the products of gamma functions as in Theorem 14.6 or the solution has an integral representation only by using elementary functions.

**16.6. Shift operators.** Calculate the polynomial function  $c_{\mathbf{m}}(\epsilon; \lambda)$  of  $\lambda$  defined in Theorem 13.7. Is it square free? See Conjecture 13.10.

Study the shift operator or Schlesinger transformation of a system of Schlesinger canonical form with a fundamental spectral type. When doesn't it defined or when is it not bijective?

**16.7. Several variables.** We have analyzed Appell hypergeometric equations in §15.10. What should be the geometric structure of singularities of more general system of equations when it has a good theory?

Describe or define operations of differential operators that are fundamental to analyze good systems of differential equations.

A series expansion of a local solution of a rigid ordinal differential equation indicates that it may be natural to think that the solution is a restriction of a solution of a system of differential equations with several variables (cf. Theorem 10.1 and §15.3–15.4). Study the system.

**16.8. Other problems.**

- Are there analyzable series  $\mathcal{L}$  of rigid tuples of partitions different from the series given in §15.9? Namely,  $\mathcal{L} \subset \mathcal{P}$ , the elements of  $\mathcal{L}$  are rigid, the number of isomorphic classes of  $\mathcal{L} \cap \mathcal{P}^{(n)}$  are bounded for  $n \in \mathbb{Z}_{>0}$  and the following condition is valid.

Let  $\mathbf{m} = k\mathbf{m}' + \mathbf{m}''$  with  $k \in \mathbb{Z}_{>0}$  and rigid tuples of partitions  $\mathbf{m}$ ,  $\mathbf{m}'$  and  $\mathbf{m}''$ . If  $\mathbf{m} \in \mathcal{L}$ , then  $\mathbf{m}' \in \mathcal{L}$  and  $\mathbf{m}'' \in \mathcal{L}$ . Moreover for any  $\mathbf{m}'' \in \mathcal{L}$ , this decomposition  $\mathbf{m} = k\mathbf{m}' + \mathbf{m}''$  exists with  $\mathbf{m} \in \mathcal{L}$ ,  $\mathbf{m}' \in \mathcal{L}$  and  $k \in \mathbb{Z}_{>0}$ . Furthermore  $\mathcal{L}$  is indecomposable. Namely if  $\mathcal{L} = \mathcal{L}' \cup \mathcal{L}''$  so that  $\mathcal{L}'$  and  $\mathcal{L}''$  satisfy these conditions, then  $\mathcal{L}' = \mathcal{L}$  or  $\mathcal{L}'' = \mathcal{L}$ .

- Characterize the ring of automorphisms and that of endomorphisms of the localized Weyl algebra  $W(x)$ .
- In general, different procedures of the reduction of the universal operator  $P_{\mathbf{m}}u = 0$  give different integral representations and series expansions of its solution (cf. Example 10.2, Remark 10.3 and the last part of §15.3). Analyze the difference.

## 17. APPENDIX

In this section we give a theorem which is proved by K. Nuida. The author greatly thanks to K. Nuida for allowing the author to put the theorem with its proof in this section.

Let  $(W, S)$  be a Coxeter system. Namely,  $W$  is a group with the set  $S$  of generators and under the notation  $S = \{s_i; i \in I\}$ , the fundamental relations among the generators are

$$(17.1) \quad s_k^2 = (s_i s_j)^{m_{i,j}} = e \quad \text{and} \quad m_{i,j} = m_{j,i} \quad \text{for} \quad \forall i, j, k \in I \quad \text{satisfying} \quad i \neq j.$$

Here  $m_{i,j} \in \{2, 3, 4, \dots\} \cup \{\infty\}$  and the condition  $m_{i,j} = \infty$  means  $(s_i s_j)^m \neq e$  for any  $m \in \mathbb{Z}_{>0}$ . Let  $E$  be a real vector space with the basis set  $\Pi = \{\alpha_i; i \in I\}$  and define a symmetric bilinear form  $(\mid)$  on  $E$  by

$$(17.2) \quad (\alpha_i \mid \alpha_i) = 2 \quad \text{and} \quad (\alpha_i \mid \alpha_j) = -2 \cos \frac{\pi}{m_{i,j}}.$$

Then the Coxeter group  $W$  is naturally identified with the reflection group generated by the reflections  $s_{\alpha_i}$  with respect to  $\alpha_i$  ( $i \in I$ ). The set  $\Delta_\Pi$  of the roots of  $(W, S)$  equals  $W\Pi$ , which is a disjoint union of the set of positive roots  $\Delta_\Pi^+ := \Delta_\Pi \cap \sum_{\alpha \in \Pi} \mathbb{Z}_{\geq 0} \alpha$  and the set of negative roots  $\Delta_\Pi^- := -\Delta_\Pi^+$ . For  $w \in W$  the length  $L(w)$  is the minimal number  $k$  with the expression  $w = s_{i_1} s_{i_2} \cdots s_{i_k}$  ( $i_1, \dots, i_k \in I$ ). Defining  $\Delta_\Pi(w) := \Delta_\Pi^+ \cap w^{-1} \Delta_\Pi^-$ , we have  $L(w) = \#\Delta_\Pi(w)$ .

Fix  $\beta$  and  $\beta' \in \Delta_\Pi$  and put

$$(17.3) \quad W_{\beta'}^\beta := \{w \in W; \beta' = w\beta\} \quad \text{and} \quad W^\beta := W_{\beta}^\beta.$$

**Theorem 17.1** (K. Nuida). *Retain the notation above. Suppose  $W_{\beta'}^\beta \neq \emptyset$  and*

*there exist no sequence  $s_{i_1}, s_{i_2}, \dots, s_{i_k}$  of elements of  $S$  such that*

$$(17.4) \quad \begin{cases} k \geq 3, \\ s_{i_\nu} \neq s_{i_{\nu'}} \quad (1 \leq \nu < \nu' \leq k), \\ m_{i_\nu, i_{\nu+1}} \quad \text{and} \quad m_{i_1, i_k} \quad \text{are odd integers} \quad (1 \leq \nu < k). \end{cases}$$

*Then an element  $w \in W_{\beta'}^\beta$  is uniquely determined by the condition*

$$(17.5) \quad L(w) \leq L(v) \quad (\forall v \in W_{\beta'}^\beta).$$

*Proof.* Put  $\Delta_\Pi^\beta := \{\gamma \in \Delta_\Pi^+; (\beta \mid \gamma) = 0\}$ . First note that the following lemma.

**Lemma 17.2.** *If  $w \in W_{\beta'}^\beta$  satisfies (17.5), then  $w\Delta_\Pi^\beta \subset \Delta_\Pi^+$ .*

In fact, if  $w \in W_{\beta'}^\beta$  satisfies (17.5) and there exists  $\gamma \in \Delta_\Pi^\beta$  satisfying  $w\gamma \in \Delta_\Pi^-$ , then there exists  $j$  for a minimal expression  $w = s_{i_1} \cdots s_{i_{L_\Pi(w)}}$  such that  $s_{i_{j+1}} \cdots s_{i_{L_\Pi(w)}} \gamma = \alpha_{i_j}$ , which implies  $W_{\beta'}^\beta \ni v := ws_\gamma = s_{i_1} \cdots s_{i_{j-1}} s_{i_{j+1}} \cdots s_{i_{L_\Pi(w)}}$  and contradicts to (17.5).

It follows from [Br] that the assumption (17.4) implies that  $W^\beta$  is generated by  $\{s_\gamma; \gamma \in \Delta_\Pi^\beta\}$ . Putting  $\Pi^\beta = \Delta_\Pi^\beta \setminus \{r_1 \gamma_1 + r_2 \gamma_2 \in \Delta_\Pi^\beta; \gamma_2 \notin \mathbb{R} \gamma_1, \gamma_j \in \Delta_\Pi^\beta \text{ and } r_j > 0 \text{ for } j = 1, 2\}$  and  $S^\beta = \{s_\gamma; \gamma \in \Pi^\beta\}$ , the pair  $(W^\beta, S^\beta)$  is a Coxeter system and moreover the minimal length of the expression of  $w \in W^\beta$  by the product of the elements of  $S^\beta$  equals  $\#(\Delta_\Pi^\beta \cap w^{-1} \Delta_\Pi^-)$  (cf. [Nu, Theorem 2.3]).

Suppose there exist two elements  $w_1$  and  $w_2 \in W_{\beta'}^\beta$  satisfying  $L(w_j) \leq L(v)$  for any  $v \in W_{\beta'}^\beta$  and  $j = 1, 2$ . Since  $e \neq w_1^{-1} w_2 \in W^\beta$ , there exists  $\gamma \in \Delta_\Pi^\beta$  such that  $w_1^{-1} w_2 \gamma \in \Delta_\Pi^-$ . Since  $-w_1^{-1} w_2 \gamma \in \Delta_\Pi^\beta$ , Lemma 17.2 assures  $-w_2 \gamma = w_1(-w_1^{-1} w_2 \gamma) \in \Delta_\Pi^+$ , which contradicts to Lemma 17.2.  $\square$

The above proof shows the following corollary.

**Corollary 17.3.** *Retain the assumption in Theorem 17.1. For an element  $w \in W_{\beta'}^{\beta}$ , the condition (17.5) is equivalent to  $w\Delta_{\Pi}^{\beta} \subset \Delta_{\Pi}^{+}$ .*

*Let  $w \in W_{\beta'}^{\beta}$  satisfying (17.5). Then*

$$(17.6) \quad W_{\beta'}^{\beta} = w \langle s_{\gamma} ; (\gamma|\beta) = 0, \gamma \in \Delta_{\Pi}^{+} \rangle.$$

#### REFERENCES

- [Ao] Aomoto K., A personal communication, 2011.
- [AK] Appell K. and J. Kampé de Fériet, Fonctions hypergéométriques et hypersphériques polynômes d'Hermite, Gauthier-Villars, 1926.
- [BH] Beukers F. and G. Heckman, Monodromy for the hypergeometric function  ${}_nF_{n-1}$ , *Invent. Math.* **95** (1989), 325–354.
- [Br] Brink B., On centralizers of reflections in Coxeter groups, *Bull. London Math. Soc.* **28** (1996) 465–470
- [CB] Crawley-Boevey, W., On matrices in prescribed conjugacy classes with no common invariant subspaces and sum zero, *Duke Math. J.* **118** (2003), 339–352.
- [DR] Dettweiler, M. and S. Reiter, An algorithm of Katz and its applications to the inverse Galois problems, *J. Symbolic Comput.* **30** (2000), 761–798.
- [DR2] ———, Middle convolution of Fuchsian systems and the construction of rigid differential systems, *J. Algebra* **318** (2007), 1–24.
- [Dix] Dixmier, J., Sur les algèbres de Weyl, *Bull. Soc. Math. France* **96** (1968), 209–242.
- [EMO] Erdelyi, A., W. Magnus, F. Oberhettinger and F. G. Tricomi, *Higher Transcendental Functions*, 3 volumes, McGraw-Hill Book Co., New York, 1953.
- [Ge] Gelfand, I. M., General theory of hypergeometric functions, *Soviet Math. Dokl.* **33** (1986), 573–577.
- [Gl] Gleizer, O., Some explicit solutions of additive Deligne-Simpson problem and their applications, *Adv. Math.* **178** (2003), 311–374.
- [Ha] Haraoka, Y., Integral representations of solutions of differential equations free from accessory parameters, *Adv. Math.* **169** (2002), 187–240.
- [HF] Haraoka, Y. and G. M. Filipuk, Middle convolution and deformation for Fuchsian systems, *J. Lond. Math. Soc.* **76** (2007), 438–450.
- [HY] Haraoka, Y. and T. Yokoyama, Construction of rigid local systems and integral representations of their sections, *Math. Nachr.* **279** (2006), 255–271.
- [HO] Heckman, G. J. and E. M. Opdam, Root systems and hypergeometric functions I, *Comp. Math.* **64** (1987), 329–352.
- [Hi] Hiroe, K., Twisted Euler transform of differential equations with an irregular singular point, preprint.
- [Kc] Kac, V. C., *Infinite dimensional Lie algebras*, Third Edition, *Cambridge Univ. Press* 1990.
- [Kz] Katz, N. M., *Rigid Local Systems*, Annals of Mathematics Studies **139**, *Princeton University Press* 1995.
- [Kh] Kohn, M., *Global analysis in linear differential equations*, *Kluwer Academic Publishers*, 1999.
- [Ko] Kostov, V. P., On the Deligne-Simpson problem, *Proc. Steklov Inst. Math.* **238** (2002), 148–185.
- [Ko2] ———, On some aspects of the Deligne-Simpson problem, *J. Dynam. Control Systems* **9** (2003), 303–436.
- [Ko3] ———, The Deligne-Simpson problem for zero index of rigidity, *Perspective in Complex Analysis, Differential Geometry and Mathematical Physics*, *World Scientific* 2001, 1–35.
- [Ko4] ———, The Deligne-Simpson problem — a survey, *J. Algebra* **281** (2004), 83–108.
- [Le] Levelt, A. H. M., Hypergeometric functions III, *Indag. Math.* **23** (1961), 386–403.
- [MWZ] Magyar, P., J. Weyman and A. Zelevinski, Multiple flag variety of finite type, *Adv. in Math.* **141** (1999), 97–118.
- [Nu] Nuida, K., On centralizers of parabolic subgroups in Coxeter groups, to appear in *Journal of Group Theory*.
- [Oc] Ochiai, H., A personal communication, 2008.
- [OTY] Okubo, K., K. Takano and S. Yoshida, A connection problem for the generalized hypergeometric equations, *Funkcial. Ekvac.* **31** (1988), 483–495.
- [O1] Oshima, T., A definition of boundary values of solutions of partial differential equations with regular singularities, *Publ. RIMS Kyoto Univ.* **19** (1983), 1203–1230.

- [O2] ———, A quantization of conjugacy classes of matrices, *Advances in Math.* **196** (2005), 124–146.
- [O3] ———, Annihilators of generalized Verma modules of the scalar type for classical Lie algebras, ‘Harmonic Analysis, Group Representations, Automorphic forms and Invariant Theory’, in honor of Roger Howe, Vol. 12, Lecture Notes Series, National University of Singapore, 2007, 277–319.
- [O4] ———, Commuting differential operators with regular singularities, *Algebraic Analysis of Differential Equations*, Springer-Verlag, Tokyo, 2007, 195–224.
- [O5] ———, Heckman-Opdam hypergeometric functions and their specializations, *Harmonische Analysis und Darstellungstheorie Topologischer Gruppen*, Mathematisches Forschungsinstitut Oberwolfach, Report **49** (2007), 38–40.
- [O6] ———, Classification of Fuchsian systems and their connection problem, preprint, arXiv:0811.2916, 2008, 29pp.
- [O7] ———, Katz’s middle convolution and Yokoyama’s extending operation, preprint, arXiv:0812.1135, 2008, 18pp.
- [O8] ———, Okubo, a computer program for Katz/Yokoyama/Oshima algorithms, <ftp://akagi.ms.u-tokyo.ac.jp/pub/math/okubo/okubo.zip>, 2007-8.
- [OS] Oshima T. and N. Shimeno, Heckman-Opdam hypergeometric functions and their specializations, *RIMS Kôkyûroku Bessatsu* **B20** (2010), 129–162.
- [Ro] Roberts, D. P., Rigid Jordan Tuples, preprint, <http://cda.morris.umn.edu/~roberts/research/rjt.ps>.
- [Sc] Scott, L. L., Matrices and cohomology, *Ann. Math.* **105**(1977), 473–492.
- [Si] Simpson, C. T., Products of Matrices, Canadian Math. Soc. Conference Proceedings **12**, AMS, Providence RI (1991), 157–185.
- [SV] Strambach, K. and Völkein H., On linearly rigid tuples, *J. reine angew. Math.* **510** (1999), 57–62.
- [Sz] Szaboó S., Deformations of Fuchsian equations and logarithmic connections, arXiv:math/0703230v3, 2008, preprint.
- [SW] Slavyanov S. Yu. and Lay W., *Special Functions, A Unified Theory Based on Singularities*, Oxford Univ. Press, Oxford New York, 2000.
- [Wa] Watson, G. N., *A Treatise on Bessel Functions*, 2nd edition, Cambridge Univ. Press, London, 1948.
- [WW] Whittaker, E. T. and G. N. Watson, *A Course of Modern Analysis*, 4th edition, Cambridge University Press, London, 1955.
- [Yo] Yokoyama, T., On an irreducibility condition for hypergeometric systems, *Funkcialaj Ekvacioj* **38** (1995), 11–19.
- [Yo2] ———, Construction of systems of differential equations of Okubo normal form with rigid monodromy, *Math. Nachr.* **279** (2006), 327–348.
- [Yo3] ———, Recursive calculation of connection formulas for systems of differential equations of Okubo normal form, preprint, 2009.
- [Yos] Yoshida M., Construction of a Moduli Space of Gauss Hypergeometric Differential Equations, *Funkcial. Ekvac.* **24** (1981), 1–10.



## INDEX

$\alpha_0, \alpha_\ell, \alpha_{\mathbf{m}}$ , 71–73  
 $\Delta, \Delta_+, \Delta_-$ , 71  
 $\Delta^{re}, \Delta_+^{re}, \Delta_-^{re}, \Delta^{im}, \Delta_+^{im}, \Delta_-^{im}$ , 71  
 $\bar{\Delta}_+$ , 74  
 $\Delta(\mathbf{m}), \Delta(w)$ , 76, 77  
 $[\Delta(\mathbf{m})]$ , 79, 141, 157, 163, 168  
 $\partial, \partial_\ell, \partial_{max}$ , 55  
 $\partial^\lambda$ , 15  
 $(\gamma)_k$ , 6  
 $[\lambda]_{(k)}$ , 19  
 $|\{\lambda_{\mathbf{m}}\}|$ , 42, 74, 120  
 $\Lambda_0, \Lambda_{j,\nu}, \Lambda^0, \Lambda_{j,\nu}^0, \Lambda(\lambda)$ , 74  
 $(\mu)_\nu$ , 15  
 $\Pi, \Pi', \Pi(\mathbf{m})$ , 71, 79  
 $\varpi$ , 103  
 $\vartheta$ , 15  
Ad, Adei, 13  
AdV, AdV<sup>0</sup>, 29  
B, 71  
B<sub>r</sub>(c), 24  
 $c(\lambda_{j,\nu} \rightsquigarrow \lambda_{j',\nu'})$ , 116  
 $c_{\mathbf{m}}(\epsilon; \lambda)$ , 112  
 $\tilde{D}_4, \tilde{E}_6, \tilde{E}_7, \tilde{E}_8$ , 72, 135  
 $D_4^{(m)}, E_6^{(m)}, E_7^{(m)}, E_8^{(m)}$ , 80, 96  
 $d_\ell(\mathbf{m})$ , 54  
 $d_{max}, \ell_{max}$ , 55  
EO<sub>n</sub>, 62, 150  
f $\mathbf{m}$ , 67  
 ${}_nF_{n-1}$ , 6  
gcd, 40  
h( $\alpha$ ), 76  
H<sub>n</sub>, 62, 145  
 $\mathfrak{h}_p, \mathfrak{h}_p^\vee, \bar{\mathfrak{h}}_p$ , 74, 75  
I, I', 71  
 $I_c^\mu, \tilde{I}_c^\mu$ , 16  
idx, 41  
idx $\mathbf{m}$ , 104  
I<sub>p</sub>, 74  
L, 13  
L( $\mathbf{m}; \lambda$ ), 42  
L(w), 76  
mc<sub>μ</sub>, 16  
 $\mathbf{m}(k), \lambda(k), \mu(k), \ell(k)$ , 57  
M(n,  $\mathbb{C}$ ), M(m<sub>1</sub>, m<sub>2</sub>,  $\mathbb{C}$ ), 42  
N<sub>ν</sub>( $\mathbf{m}$ ), 57, 59, 62, 68  
 $\mathcal{O}, \hat{\mathcal{O}}, \mathcal{O}_c, \mathcal{O}_c(\mu, m)$ , 24  
ord, 13, 41  
P<sub>p+1,n</sub>, P<sub>n</sub>, 99, 141, 176  
 $\mathcal{P}, \mathcal{P}_{p+1}, \mathcal{P}^{(n)}, \mathcal{P}_{p+1}^{(n)}$ , 41  
Pidx, 41  
P<sup>∨</sup>, P\*, 46  
Q<sub>+</sub>, 71  
R, 13  
RAd, RAdL, 14  
RAdV, 29  
Ridx, 66  
R $\mathbf{m}(\epsilon, \lambda)$ , 108  
s, s $\mathbf{m}$ , 41  
s<sub>α</sub>, s<sub>i</sub>, 71  
S<sub>∞</sub>, S'<sub>∞</sub>, 41

T<sub>φ</sub><sup>\*</sup>, 13  
Top, 59  
W<sub>∞</sub>, W'<sub>∞</sub>,  $\widetilde{W}_\infty$ , 71  
w $\mathbf{m}$ , 76  
W[x; ξ], W(x; ξ), 12  
X<sub>6</sub>, 62  
Z(A), Z( $\mathbf{M}$ ), 43, 53, 91, 93  
  
accessory parameter, 45  
addition, 16  
    confluence, 29  
    around the origin, 29  
affine, 72  
Airy equation, 19  
apparent singularity, 27, 28, 40  
  
characteristic exponent, 24  
    (compatible) shift, 108  
    distinct, 40  
    distinguished, 43  
    generalized, 37  
confluence, 28  
    addition, 28  
connection coefficient, 116  
    generalized, 130, 153, 159  
convolution, 53  
coordinate transformation, 13  
    linear fractional, 55  
Coxeter system, 189  
  
Deligne-Simpson problem, 4  
differential equation/operator  
    complete model, 187  
    cyclic, 20  
    degree, 13  
    dual, 46  
    irreducible, 21, 27  
    mutually prime, 20  
    order, 13  
direct decomposition, 95  
    example, 100  
dual partition, 38  
Dynkin diagram, 72, 137  
  
Euler transformation, 16  
even family, 151  
    EO<sub>4</sub>, 113, 152  
    shift operator, 152  
    connection coefficient, 151  
    generalized, 153  
    reducibility, 151, 155  
  
fractional derivation, 16  
Fuchs relation, 27, 40, 42, 74  
Fuchsian differential equation/operator, 26  
    dual, 46  
    locally non-degenerate, 91  
    normal form, 44  
    normalized, 37  
    universal model, 66  
    fundamental, 80

- gauge transformation, 13
- Heun's equation, 28, 54, 63
- hypergeometric equation/function
  - Appell, 179
  - $F_1$ , 179
  - $F_2$ , 184
  - $F_3$ , 184
  - $F_4$ , 181
  - confluence, 181
- Gauss, 3, 17, 84, 111
  - confluence, 30
  - Euler transformation, 86
  - integral expression, 85
  - reducibility, 105
  - versal, 30
- generalized, 6, 145
  - connection coefficient, 133, 148
  - local solution, 146
  - recurrence relation, 147, 148
  - shift operator, 115
  - versal, 150
- imaginary root, 72
- indicial equation, 24
- Jordan-Pochhammer, 19, 98, 118, 141
  - exceptional parameter, 54
  - generalized, 98, 106, 176
  - versal, 30, 143
- Kac-Moody root system, 71
- Katz's rigidity, 93
- Kummer's equation, 31
- Laplace transformation, 13, 14
- linear fractional transformation, 55
- locally non-degenerate, 91
- middle convolution, 16
- minimal expression, 76
- monodromy, 27, 90
  - generator, 90
  - irreducible, 87
- odd family, 155
  - connection coefficient, 155
  - reducibility, 156
- Okubo normal form, 21
- Okubo type, 114, 179
  - polynomial solution, 115
- parabolic cylinder function, 31
- Pell equation, 99
- Pochhammer contour, 16
- polynomial solution, 115
- positive root, 72
- real root, 72
- reduced representative, 13
- reflection, 71
- regular singularity, 23
  - local solution, 24
  - normalized, 24
- Riemann scheme, 18, 32
  - generalized, 39
- Riemann-Liouville integral, 16
- Schlesinger canonical form, 21
- Scott's lemma, 92
- shift operator, 108
- simple reflection, 71
- simple root, 71
- Simpson's list, 138
- spectral type, *see also* tuple of partitions, 40
- tuple of partitions, 40
  - basic, 55, 135
    - Dynkin diagram, 137
    - index of rigidity = -2, 63
    - index of rigidity = 0, 59, 63
    - index of rigidity  $\geq -6$ , 135
  - direct decomposition, 95
  - divisible, 40, 64
  - fundamental, 67
  - index, 72
  - index of rigidity, 45
    - = 0, 135
  - indivisible, 40
  - irreducibly realizable, 44
  - isomorphic, 41
  - monotone, 40
  - order, 41
  - realizable, 44
  - rigid, 45, 138
    - (sub)maximal series, 167
    - 1111,211,22, 113, 153
    - 21,21,21,21, 54
    - 211,211,211, 157, 158
    - 211,22,31,31, 161
    - 21111,222,33, 68, 138
    - 22,22,22,31, 162
    - 221,221,221, 162
    - 831,93,93,93, 107
    - minimal series, 175, 177
    - order  $\leq 4$ , 157
    - order  $\leq 8$ , 138
    - Simpson's list, 138
    - Yokoyama's list, 179
  - rigid decomposition, 99
  - simply reducible, 67–69, 167
  - standard, 40
  - trivial, 40
- universal model, 66
- versal
  - addition, 28
  - operator, 30
- Weber's equation, 31
- Weyl algebra, 12
- Weyl group, 71
  - length, 76
  - minimal expression, 76
- Wronskian, 28, 128, 129, 153, 159

GRADUATE SCHOOL OF MATHEMATICAL SCIENCES, UNIVERSITY OF TOKYO, 7-3-1, KOMABA,  
MEGURO-KU, TOKYO 153-8914, JAPAN  
*E-mail address:* [oshima@ms.u-tokyo.ac.jp](mailto:oshima@ms.u-tokyo.ac.jp)

UTMS

- 2010–15 Nobuhiro Nakamura:  *$Pin^-(2)$ -monopole equations and intersection forms with local coefficients of 4-manifolds.*
- 2010–16 Kenji Nakahara: *Uniform estimate for distributions of the sum of i.i.d random variables with fat tail: threshold case.*
- 2010–17 Hidetaka Sakai: *Isomonodromic deformation and 4-dimensional Painlevé type equations.*
- 2010–18 Takahito Kashiwabara: *On a finite element approximation of the Stokes problem under leak or slip boundary conditions of friction type.*
- 2010–19 Yusaku Tiba: *Holomorphic curves into the product space of the Riemann spheres.*
- 2010–20 Nariya Kawazumi and Yusuke Kuno: *The Chas-Sullivan conjecture for a surface of infinite genus.*
- 2011–1 Qing Liu: *Fattening and comparison principle for level-set equation of mean curvature type.*
- 2011–2 Oleg Yu. Imanuvilov, Gunther Uhlmann, and Masahiro Yamamoto: *Global uniqueness in determining the potential for the two dimensional Schrödinger equation from cauchy data measured on disjoint subsets of the boundary.*
- 2011–3 Junjiro Noguchi: *Connections and the second main theorem for holomorphic curves.*
- 2011–4 Toshio Oshima and Nobukazu Shimeno: *Boundary value problems on Riemannian symmetric spaces of the noncompact type.*
- 2011–5 Toshio Oshima: *Fractional calculus of Weyl algebra and Fuchsian differential equations.*

The Graduate School of Mathematical Sciences was established in the University of Tokyo in April, 1992. Formerly there were two departments of mathematics in the University of Tokyo: one in the Faculty of Science and the other in the College of Arts and Sciences. All faculty members of these two departments have moved to the new graduate school, as well as several members of the Department of Pure and Applied Sciences in the College of Arts and Sciences. In January, 1993, the preprint series of the former two departments of mathematics were unified as the Preprint Series of the Graduate School of Mathematical Sciences, The University of Tokyo. For the information about the preprint series, please write to the preprint series office.

ADDRESS:

Graduate School of Mathematical Sciences, The University of Tokyo  
3–8–1 Komaba Meguro-ku, Tokyo 153-8914, JAPAN  
TEL +81-3-5465-7001 FAX +81-3-5465-7012