

UTMS 2011–24

November 15, 2011

**An optimal execution problem in
geometric Ornstein Uhlenbeck price process**

by

Takashi KATO

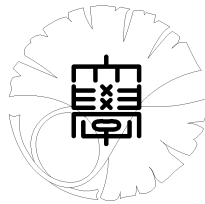

UNIVERSITY OF TOKYO

GRADUATE SCHOOL OF MATHEMATICAL SCIENCES

KOMABA, TOKYO, JAPAN

An Optimal Execution Problem in Geometric Ornstein Uhlenbeck Price Process

Takashi Kato*

Abstract

We study the optimal execution problem in the presence of market impact where the security price follows a geometric Ornstein Uhlenbeck process which has mean reverting property and show that an optimal strategy is a mixture of initial/terminal block liquidation and intermediate gradual liquidation. Mean reverting property is strongly related to the resilience of market impact, as in several papers which have studied optimal execution in a limit order book (LOB) model, such as Alfonsi et al. [1] and Obizhaeva and Wang [13]. It is interesting that despite the fact that the model in this paper is different from the LOB model, the form of our optimal strategy is quite similar to those of [1] and [13]. Our results in this paper is also placed as a representative and significant example of the (generalized) framework of Kato [11] where market impact causes gradual liquidation.

Keywords : Optimal execution, Market impact, Liquidity problems, Ornstein Uhlenbeck process, Gradual liquidation

1 Introduction

The basic framework of the optimal execution (liquidation) problem was established in Bertsimas and Lo[5] and the theory of optimal execution has been developed by Almgren and Chriss[4], He and Mamaysky[8], Huberman and Stanzl[10], Subramanian and Jarrow[16] and many others. Such a problem often shows up in trading operations, when a trader tries to execute a large amount of a security. In these cases, he/she should be careful about liquidity problems and especially should never neglect the market impact (MI) which plays an important role. MI means the effect that a trader's investment behavior affects on security prices.

To study MI for a trader's execution policy, we consider a case where a trader sells his/her shares of the security by predicting a decrease in price of the security. In a frictionless market, a (risk neutral) trader should sell all the shares as soon as possible, so his/her optimal strategy

*Graduate School of Mathematical Sciences, The University of Tokyo, 3-8-1 Komaba, Meguro, Tokyo, 153-8914 Japan. (takashi@ms.u-tokyo.ac.jp).

Mathematical Subject Classification (2010) 91G80, 93E20, 49L20
JEL Classification (2010) G33, G11

is the block liquidation at the initial time. However, in the real market a trader takes time to liquidate. So it is significant to find out what factors cause such gradual liquidation.

Convexity of MI is one of the reasons to dissuade a trader from block liquidation. As shown in examples in Kato[11], when a trader is risk neutral and the market is Black Scholes type, a quadratic MI function causes gradual liquidation whereas a block liquidation is optimal when MI is linear. However, many traders in the real market execute their sales by taking time in spite of recognizing that MI is not always convex. Risk aversion of a trader's utility function also affects a trader's execution policy motivating an incentive to take more time for trading. Schied and Schöneborn[15] consider an optimization problem in relation with a risk averse utility function and clarify the relation between the measure of risk aversion and the form of optimal strategies.

Another important motive is that due to the effect of MI, security price may recover after downward movement in price. In this paper, to consider the price recovery effect, we focus on the case where the process of a security price has the mean reverting property, especially when it follows a geometric Ornstein Uhlenbeck (OU) process. We adopt the framework of Kato[11]: we first consider discrete time models of an optimal execution problem and then derive the continuous time model as their limit. To treat the geometric OU process as a security price process, we generalize the main results of Kato[11] mathematically. We explicitly solve the optimization problem with linear MI and show that the optimal strategy is a mixture of initial/terminal block liquidation and intermediate gradual liquidation. Our example in this paper is also placed as a representative case where a gradual liquidation is necessary in the framework of Kato[11] even if there is linear MI and the trader is risk neutral.

Our result is strongly related to studies of the limit order book (LOB) model. In the LOB model, a trader's selling decreases buy limit orders, thus expanding the bid ask spread temporarily, and new buy limit orders appear, letting the bid ask spread shrinks as time passes. The minimization problem of expected execution cost in a block-shaped LOB model with exponential resilience of MI is studied in Obizhaeva and Wang[13]. A mathematical generalization of the results of Obizhaeva and Wang[13] is given in Alfonsi et al.[1] and Predoiu et al. [14]. Moreover, Makimoto and Sugihara[12] treat a model of optimal execution under stochastic liquidity. It is interesting that despite the fact that the model in this paper is different from the LOB model, the form of an optimal execution strategy in our model becomes quite similar to the results in these papers. Indeed, when our security price process has no volatility, the form of our optimal strategy coincides with those in Alfonsi et al.[1] and Obizhaeva and Wang[13]: the speed of intermediate liquidation is constant. When the volatility is larger than zero, the speed decreases as in Makimoto and Sugihara[12].

This paper is organized as follows. In Section 2, we review our model of optimization problems and list our assumptions. In Section 3, we give some generalizations of the results of Kato[11], in particular the convergence of the value functions. Section 4 is our main interest. We introduce the optimization problem in the geometric OU price process and solve it explicitly. Section 5 gives a note on the positivity of an optimal strategy and the possibility of price manipulation in our framework. Section 6 summarizes our studies. Section 7 gives the proofs of our results.

2 The Model

Our model is the same as in Kato[11] except for some technical assumptions. Let $(\Omega, \mathcal{F}, (\mathcal{F}_t)_{0 \leq t \leq 1}, P)$ be a filtered space which satisfies the usual condition (that is, $(\mathcal{F}_t)_t$ is right continuous and \mathcal{F}_0 contains all P -null sets) and let $(B_t)_{0 \leq t \leq T}$ be a standard one dimensional $(\mathcal{F}_t)_t$ -Brownian motion.

First we consider the discrete time model with time interval $1/n$. We assume that transaction times are only at $0, 1/n, \dots, (n-1)/n$ for $n \in \mathbb{N} = \{1, 2, 3, \dots\}$. We suppose that there are only two assets in the market: cash and a security. The price of cash is always equal to 1. We consider a single trader who has an endowment of $\Phi_0 > 0$ shares of the security. This trader executes the shares Φ_0 over a time interval $[0, 1]$, but his/her sales affect the price of the security. For $l = 0, \dots, n$, we denote by S_l^n the price of the security at time l/n and $X_l^n = \log S_l^n$. Let $s_0 > 0$ be the initial price (i.e., $S_0^n = s_0$) and $X_0^n = \log s_0$. If a trader sells the amount ψ_l^n at time l/n , the log price changes to $X_l^n - g_n(\psi_l^n)$, where $g_n : [0, \infty) \rightarrow [0, \infty)$ is a nondecreasing and continuously differentiable function which satisfies $g_n(0) = 0$, and he/she gets the amount of cash $\psi_l^n S_l^n \exp(-g_n(\psi_l^n))$ as the proceeds of his/her execution. After the trade at time l/n , X_{l+1}^n and S_{l+1}^n are given by

$$X_{l+1}^n = Y\left(\frac{l+1}{n}; \frac{l}{n}, X_l^n - g_n(\psi_l^n)\right), \quad S_{l+1}^n = \exp(X_{l+1}^n), \quad (2.1)$$

where $Y(t; r, x)$ is a solution of the following stochastic differential equation (SDE)

$$\begin{cases} dY(t; r, x) = \sigma(Y(t; r, x))dB_t + b(Y(t; r, x))dt, & t \geq r, \\ Y(r; r, x) = x \end{cases} \quad (2.2)$$

and $b, \sigma : \mathbb{R} \rightarrow \mathbb{R}$ are Lipschitz continuous functions. We assume that the functions b, σ, \hat{b} and $\hat{\sigma}$ are linear growth, where $\hat{\sigma}(s) = s\sigma(\log s)$, $\hat{b}(s) = s\{b(\log s) + \sigma(\log s)^2/2\}$. We notice that b and σ are assumed to be bounded in Kato[11], so the model in this paper is a slight generalization of Kato[11]. In our model, we remark that there is a unique solution of (2.2) for each $r \geq 0$ and $x \in \mathbb{R}$.

At the end of the time interval $[0, 1]$, the trader has the amount of cash W_n^n , where

$$W_{l+1}^n = W_l^n + \psi_l^n S_l^n \exp(-g_n(\psi_l^n)) \quad (2.3)$$

for $l = 0, \dots, n-1$ and $W_0^n = 0$. We define the space of a trader's execution strategies $\mathcal{A}_k^n(\varphi)$ as the set of $(\psi_l^n)_{l=0}^{k-1}$ such that ψ_l^n is $\mathcal{F}_{l/n}$ -measurable, $\psi_l^n \geq 0$ for each $l = 0, \dots, k-1$, and $\sum_{l=0}^{k-1} \psi_l^n \leq \varphi$.

The investor's problem is to choose an admissible trading strategy to maximize the expected utility $E[u(W_n^n, \varphi_n^n, S_n^n)]$, where $u \in \mathcal{C}$ is his/her utility function and \mathcal{C} is the set of nondecreasing continuous functions on $D = \mathbb{R} \times [0, \Phi_0] \times [0, \infty)$ which have polynomial growth rate.

For $k = 1, \dots, n$, $(w, \varphi, s) \in D$ and $u \in \mathcal{C}$, we define a (discrete time) value function $V_k^n(w, \varphi, s; u)$ by

$$V_k^n(w, \varphi, s; u) = \sup_{(\psi_l^n)_{l=0}^{k-1} \in \mathcal{A}_k^n(\varphi)} E[u(W_k^n, \varphi_k^n, S_k^n)]$$

subject to (2.1) and (2.3) for $l = 0, \dots, k-1$ and $(W_0^n, \varphi_0^n, S_0^n) = (w, \varphi, s)$. (For $s = 0$, we set $S_l^n \equiv 0$.) For $k = 0$, we put $V_0^n(w, \varphi, s; u) = u(w, \varphi, s)$. Then our problem is the same as $V_n^n(0, \Phi_0, s_0; u)$. We consider the limit of the value function $V_k^n(w, \varphi, s; u)$ as $n \rightarrow \infty$.

Let $h : [0, \infty) \rightarrow [0, \infty)$ be a nondecreasing continuous function. We introduce the following condition.

$$[A] \quad \lim_{n \rightarrow \infty} \sup_{\psi \in [0, \Phi_0]} \left| \frac{d}{d\psi} g_n(\psi) - h(n\psi) \right| = 0.$$

Let $g(\zeta) = \int_0^\zeta h(\zeta') d\zeta'$ for $\zeta \in [0, \infty)$. The function $g(\zeta)$ means an MI function in the continuous time model. For $t \in [0, 1]$ and $\varphi \in [0, \Phi_0]$ we denote by $\mathcal{A}_t(\varphi)$ the set of $(\mathcal{F}_r)_{0 \leq r \leq t}$ -progressively measurable process $(\zeta_r)_{0 \leq r \leq t}$ such that $\zeta_r \geq 0$ for each $r \in [0, t]$, $\int_0^t \zeta_r dr \leq \varphi$ almost surely and $\sup_{r, \omega} \zeta_r(\omega) < \infty$. For $t \in [0, 1]$, $(w, \varphi, s) \in D$ and $u \in \mathcal{C}$, we define $V_t(w, \varphi, s; u)$ by

$$V_t(w, \varphi, s; u) = \sup_{(\zeta_r)_{r \in \mathcal{A}_t(\varphi)}} \mathbb{E}[u(W_t, \varphi_t, S_t)]$$

subject to

$$dW_r = \zeta_r S_r dr, \quad d\varphi_r = -\zeta_r dr, \quad dS_r = \hat{\sigma}(S_r) dB_r + \hat{b}(S_r) dr - g(\zeta_r) S_r dr$$

and $(W_0, \varphi_0, S_0) = (w, \varphi, s)$. When $s > 0$, we obviously see that the process the log price of the security $X_r = \log S_r$ satisfies

$$dX_r = \sigma(X_r) dB_r + b(X_r) - g(\zeta_r) dr. \quad (2.4)$$

3 Derivation of Continuous Time Model

Following results are similar to the ones in Kato[11].

Theorem 1. Assume [A]. For each $(w, \varphi, s) \in D$, $t \in [0, 1]$ and $u \in \mathcal{C}$,

$$\lim_{n \rightarrow \infty} V_{[nt]}^n(w, \varphi, s; u) = V_t(w, \varphi, s; u), \quad (3.1)$$

where $[nt]$ is the greatest integer less than or equal to nt .

Here we make the further assumption

$$[B] \quad \mathbb{E}[\sup_{0 \leq t \leq 1} \exp(Y(t; 0, x))] \leq C e^x \text{ for some } C > 0.$$

Theorem 2. Assume [B]. For $u \in \mathcal{C}$, the function $V_t(w, \varphi, s; u)$ is continuous in $(t, w, \varphi, s) \in (0, 1] \times D$. Moreover, if $h(\infty) < \infty$, then $V_t(w, \varphi, s; u)$ converges to $Ju(w, \varphi, s)$ uniformly on any compact subset of D as $t \downarrow 0$, where

$$Ju(w, \varphi, s) = \begin{cases} \sup_{\psi \in [0, \varphi]} u\left(w + \frac{1 - e^{-h(\infty)\psi}}{h(\infty)} s, \varphi - \psi, s e^{-h(\infty)\psi}\right) & (h(\infty) > 0) \\ \sup_{\psi \in [0, \varphi]} u(w + \psi s, \varphi - \psi, s) & (h(\infty) = 0). \end{cases}$$

Theorem 3. Assume [B]. For each $r, t \in [0, 1]$ with $t + r \leq 1$, $(w, \varphi, s) \in D$ and $u \in \mathcal{C}$ it holds that $Q_{t+r}u(w, \varphi, s) = Q_t Q_r u(w, \varphi, s)$.

Next we consider a sell out condition, which is referred in Section 4 in Kato[11]. We define some spaces of admissible strategies with the sell out condition as

$$\begin{aligned}\mathcal{A}_k^{n, \text{SO}}(\varphi) &= \left\{ (\psi_l^n)_l \in \mathcal{A}_k^n(\varphi) ; \sum_{l=0}^{k-1} \psi_l^n = \varphi \right\}, \\ \mathcal{A}_t^{\text{SO}}(\varphi) &= \left\{ (\zeta_r)_r \in \mathcal{A}_t(\varphi) ; \int_0^t \zeta_r dr = \varphi \right\}.\end{aligned}$$

Now we define value functions with the sell out condition by

$$\begin{aligned}V_k^{n, \text{SO}}(w, \varphi, s; U) &= \sup_{(\psi_l^n)_l \in \mathcal{A}_k^{n, \text{SO}}(\varphi)} \mathbb{E}[U(W_k^n)], \\ V_t^{\text{SO}}(w, \varphi, s; U) &= \sup_{(\zeta_r)_r \in \mathcal{A}_t^{\text{SO}}(\varphi)} \mathbb{E}[U(W_t)]\end{aligned}$$

for a continuous, nondecreasing and polynomial growth function $U : \mathbb{R} \rightarrow \mathbb{R}$. By Theorem 1, 2, and similar arguments as in Kato[11], we can show the following.

Theorem 4. It follows that $V_{[nt]}^{n, \text{SO}}(w, \varphi, s; U) \rightarrow V_t^{\text{SO}}(w, \varphi, s; U) = V_t(w, \varphi, s; u)$ as $n \rightarrow \infty$, where $u(w, \varphi, s) = U(w)$.

Under the assumptions of this paper, we also obtain all the lemmas in Section 7.1 of Kato[11], except Lemma 1 and Lemma 4. Instead, we have the following lemmas.

Lemma 1. For each $m \in \mathbb{N}$ there is a constant $C > 0$ depending only on b, σ and m such that $\mathbb{E}[\hat{Z}(s)^m] \leq C(1 + s^m)$, where $\hat{Z}(s) = \sup_{0 \leq t \leq 1} Z(t; 0, s)$.

Lemma 2. Let $t \in [0, 1]$, $\varphi \geq 0$, $x \in \mathbb{R}$, $(\zeta_r)_{0 \leq r \leq t} \in \mathcal{A}_t(\varphi)$ and let $(X_r)_{0 \leq r \leq t}$ be given by (2.4) with $X_0 = x$. Then there is a constant $C > 0$ depending only on b and σ such that

$$\begin{aligned}& \mathbb{E} \left[\sup_{r \in [r_0, r_1]} \left| X_r - X_{r_0} + \int_{r_0}^r g(\zeta_v) dv \right|^4 \right] \\ & \leq C(r_1 - r_0)^2 \{1 + (r_1 - r_0)^3 \int_{r_0}^{r_1} \mathbb{E}[g(\zeta_v)^4] dv\}\end{aligned}\tag{3.2}$$

for each $0 \leq r_0 \leq r_1 \leq t$.

Unlike the case where b is bounded, the right hand side of (3.2) depends on $(\zeta_r)_r$. However, this makes no essential problem for proving similar results to Kato[11], except the continuity of the continuous time value function at $t = 0$ when $h(\infty) = \infty$. Thus we can complete the proofs of Theorems 1–3 similarly to Kato[11].

4 Example: Geometric OU Process

In this section we consider an example which is our main interest in this paper. Let $\beta, \sigma \geq 0$ and $F \in \mathbb{R}$. We set $b(x) = \beta(F - x)$ and $\sigma(x) \equiv \sigma$. In this case the solution Y of (2.2) is called an Ornstein Uhlenbeck process and we can write the explicit form of the log price $(X_r)_r$ as

$$X_r = e^{-\beta r} x + (1 - e^{-\beta r})F - e^{-\beta r} \int_0^r e^{\beta v} g(\zeta_v) dv + e^{-\beta r} \int_0^r e^{\beta v} dB_v.$$

We notice that the condition [B] is fulfilled.

Then we consider the case where MI is linear and the trader is risk neutral, that is, $g(\zeta) = \alpha\zeta$ for some $\alpha > 0$ and $u(w, \varphi, s) = u_{\text{RN}}(w, \varphi, s) = w$. For brevity we set $y = \sigma^2/(4\beta)$ and $z = \log s - F$. We assume $z > 2y (\geq 0)$ so that the security price goes down to the fundamental value e^F as time passes. Note that the trader in a fully liquid market should sell all the securities at the initial time i.e., the optimal strategy is an initial block liquidation. In fact, if φ is small enough, the trader's optimal policy is almost the same.

Theorem 5. *If $\varphi \leq (z - 2y)/\alpha$, then it holds that*

$$V_t(w, \varphi, s; u_{\text{RN}}) = w + \frac{1 - e^{-\alpha\varphi}}{\alpha} s. \quad (4.1)$$

The form of (4.1) is the same as in Theorem 8 of Kato[11]. The trader's (nearly) optimal strategy is given by $\hat{\zeta}_r^{I, \delta} = \varphi 1_{[0, \delta]}(r)/\delta$ with $\delta \rightarrow 0$. We call such a strategy an ‘‘almost block liquidation’’ at the initial time.

When φ is not so small, the assertion of the above theorem is not always true. The trader's selling accelerates the speed of decrease of the security price, and a quick liquidation is not always appropriate when we consider the effect of MI. Moreover, if the trader's execution makes the price go under e^F transitorily, the price will recover to e^F by delaying the sale. This gives a trader an incentive to liquidate gradually. Our purpose in the rest of this section is to derive a (nearly) optimal execution strategy explicitly.

Let $P(x) = e^{-\alpha x}(1 - \alpha x)$. Since the function P is strictly decreasing on $(-\infty, 2/\alpha]$, we can define its inverse function $P^{-1} : [-e^{-2}, \infty) \rightarrow (-\infty, 2/\alpha]$. Moreover we define the function $H(\lambda) = H_{t, \varphi}(\lambda)$ on $[0, \infty)$ by

$$H(\lambda) = \alpha \exp \left(\alpha \beta \int_0^t P^{-1}(\exp(-e^{-2\beta r} y) \lambda / \alpha) dr - \alpha \varphi + z - y \right) - \lambda,$$

We assume the following condition

$$\varphi > \frac{\max\{z, 1 + \beta\}}{\alpha}. \quad (4.2)$$

This condition means that the amount of the trader's security holdings is large enough. We see that H is nonincreasing on $[0, \infty)$ and (4.2) implies

$$H(\alpha e^{-y}) < 0 < H(0).$$

Then the equation $H(\lambda) = 0$ has the unique solution $\lambda^* = \lambda^*(t, \varphi) \in (0, \alpha e^{-y})$. The next theorem is the main result in this section.

Theorem 6. Let $t \in (0, 1]$, $(w, \varphi, s) \in D$ and assume (4.2). Then

$$\begin{aligned} V_t(w, \varphi, s; u_{\text{RN}}) &= w + \frac{s}{\alpha} \left(1 - \exp \left(-\alpha\varphi + \alpha\beta \int_0^t \xi_r^* dr \right) \right) \\ &\quad + \beta \int_0^t \xi_r^* \exp \left(F - \alpha\xi_r^* + (1 + e^{-2\beta r})y \right) dr, \end{aligned} \quad (4.3)$$

where $\xi_r^* = P^{-1}(\exp(-e^{-2\beta r}y)\lambda^*/\alpha)$.

We can construct a nearly optimal strategy as follows (with $\delta \downarrow 0$):

$$\hat{\zeta}_r^\delta = \frac{p^*}{\delta} 1_{[0, \delta]}(r) + \zeta_r^* + \frac{q^*}{\delta} 1_{[t-\delta, t]}(r), \quad (4.4)$$

where $p^* = \xi_0^* + (z - 2y)/\alpha$ and

$$\begin{aligned} \zeta_r^* &= \beta\xi_r^* + \frac{2\beta\lambda^*e^{-2\beta r}y \exp(\alpha\xi_r^* - e^{-2\beta r}y)}{\alpha^2(\alpha\xi_r^* - 2)} + \frac{2\beta y}{\alpha} e^{-2\beta r} \\ &= \beta\xi_r^* + \frac{2\beta ye^{-2\beta r}}{\alpha(2 - \alpha\xi_r^*)}, \\ q^* &= \varphi - \beta \int_0^t \xi_r^* dr - \xi_t^* - \frac{z}{\alpha} + \frac{y}{\alpha}(1 + e^{-2\beta t}). \end{aligned}$$

Here the second equality of the definition of ζ_r^* comes from $P(\xi_r^*) = \exp(-e^{-2\beta r}y) \times \lambda^*/\alpha$. By the inequalities (4.2), $z \geq 2y$, and $0 \leq \xi_r^* \leq \xi_0^* \leq 1/\alpha$, we see that p^* , ζ_r^* and q^* are all positive.

The strategy $(\hat{\zeta}_r^\delta)_r$ consists of three terms. The first term in the right hand side of (4.4) corresponds to ‘‘initial (almost) block liquidation.’’ The trader should sell p^* shares of a security at the initial time by dividing infinitely to avoid a decrease in the proceeds. The second term means ‘‘gradual liquidation.’’ The trader executes the selling gradually until the time horizon. The speed of his/her execution becomes slower as time passes. Then the trader completes liquidation by selling the rest of the shares by ‘‘terminal (almost) block liquidation’’ as the final third term. So the nearly optimal strategy is a mixture of both block liquidation and gradual liquidation, and especially we point out that the gradual liquidation is necessary in this case. Figure 1 expresses the image of an optimal strategy of the trader. Using these notations, we can rewrite the value function (4.3) as the sum of an initial cash amount and proceeds of initial/intermediate/terminal liquidation:

$$\begin{aligned} &V_t(w, \varphi, s; u_{\text{RN}}) \\ &= w + \frac{1 - e^{-\alpha p^*}}{\alpha} s + s \int_0^t e^{-\alpha\eta_r^*} (d\eta_r^* + \beta\xi_r^* dr) + \frac{1 - e^{-\alpha q^*}}{\alpha} s e^{-\alpha\eta_t^*}, \end{aligned} \quad (4.5)$$

where $\eta_t^* = \xi_t^* - (1 + e^{-2\beta t})y/\alpha + z/\alpha$.

Here we consider the special case of $\sigma = 0$ for a while. In this case the form of the value function and its nearly optimal strategy becomes simple and we can weaken the assumption (4.2) to $\varphi > z/\alpha$. We define the function $C(p) = C_{t, \varphi}(p)$, $x \in \mathbb{R}$, by

$$\begin{aligned} C_{t, \varphi}(p) &= e^{\alpha p - z} H_{t, \varphi}(\alpha P(xp - z/\alpha))/\alpha \\ &= \exp(\alpha(t\beta + 1)p - \alpha\varphi - t\beta z) + \alpha p - z - 1. \end{aligned}$$

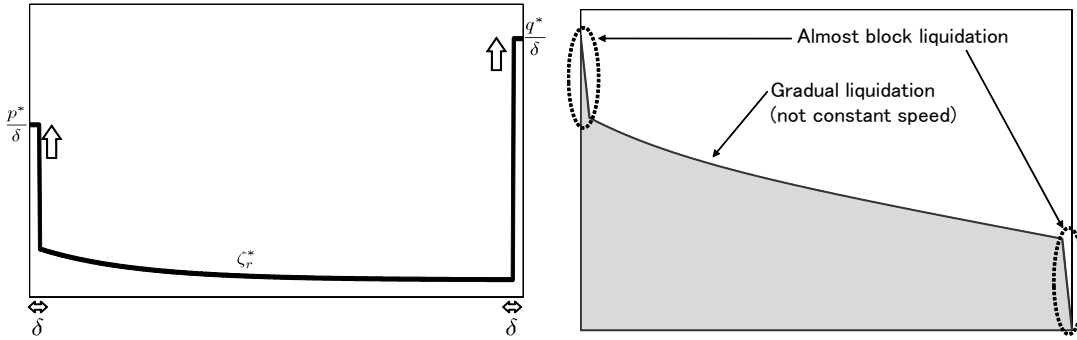

Figure 1: The form of a nearly optimal strategy $(\zeta_r^\delta)_r$ (the upper graph) and the corresponding process of the amount of the security holdings (the lower graph) when $\sigma > 0$. Horizontal axis is the time r .

Since $C(p)$ is strictly increasing and $C(z/\alpha) < 0 < C((\varphi - z/\alpha)/(1 + \beta t))$, the equation $C(p) = 0$ has a unique solution $p^* = p^*(t, \varphi) \in (\varphi - z/\alpha, (\varphi - z/\alpha)/(1 + \beta t))$. We have the following.

Corollary 1. *Let $t \in (0, 1]$, $(w, \varphi, s) \in D$ and assume $\varphi > z/\alpha$. Then it holds that*

$$V_t(w, \varphi, s; u_{RN}) = w + \frac{1 - e^{-\alpha(p^* + q^*)}}{\alpha} s + t s e^{-\alpha p^*} \zeta^*, \quad (4.6)$$

where $\zeta^* = \zeta^*(t, \varphi)$ and $q^* = q^*(t, \varphi)$ are given by

$$\zeta^* = \beta(p^* - z/\alpha), \quad q^* = \varphi - p^* - t\zeta^*.$$

We see easily that $p^*, \zeta^*, q^* > 0$. A nearly optimal strategy is

$$\zeta_r^\delta = \frac{p^*}{\delta} 1_{[0, \delta]}(r) + t\zeta^* + \frac{q^*}{\delta} 1_{[t-\delta, t]}(r).$$

In this case we also decompose a nearly optimal strategy into three parts: initial (almost) block liquidation, gradual liquidation, and terminal (almost) block liquidation. Moreover the speed of the gradual liquidation ζ^* is constant. The image of their form is in Figure 2. In fact, the security price is equal to $se^{-\alpha p^*}$ and is also constant on $(\delta, 1 - \delta)$.

This result is quite similar to Alfonsi et al.[1] and Obizhaeva and Wang[13], despite the fact that there is a little difference between their models and ours. We consider the geometric OU process for a security price. On the other hand Alfonsi et al.[1] and Obizhaeva and Wang[13] assumed that the process of a security price follows arithmetic Brownian motion (or a martingale) and there is exponential (or some more general shape of) resilience for MI in LOB model. The relation between the mean reverting property of an OU process and the resilience of MI causes the similarity of results.

5 A Note on Price Manipulation

In a viable execution model, the absence of price manipulation should be guaranteed and an optimal strategy should always be nonnegative (i.e., a selling strategy should not include

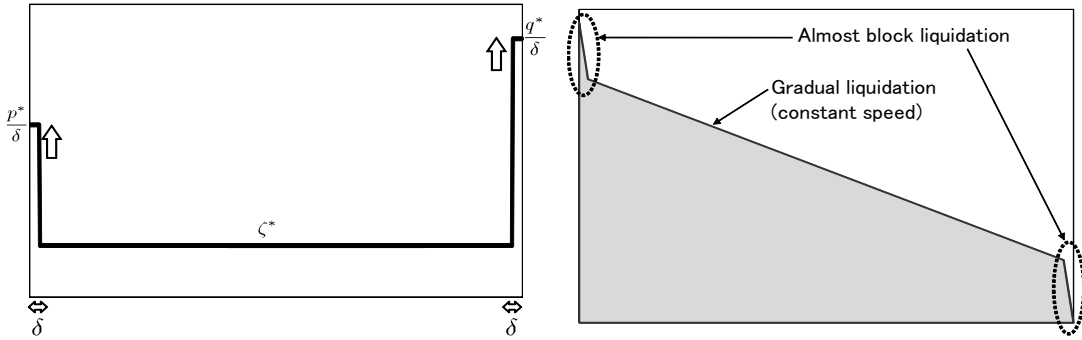

Figure 2: The forms of a nearly optimal strategy $(\zeta_r^\delta)_r$ (the upper graph) and the corresponding process of the amount of the security holdings (the lower graph) when $\sigma = 0$. Horizontal axis is the time r .

purchasing.) The conditions for viability in a LOB model are studied in Alfonsi and Schied[2], Alfonsi et al.[3], Gatheral[6], Gatheral et al.[7], Huberman and Stanzl[9] and others.

In this section we extend the definition of admissible strategies of our model to permit purchasing and consider the possibility of a price manipulation strategy. We consider the following optimization problem

$$V_t^{\text{ex}}(w, \varphi, s; u_{\text{RN}}) = \sup_{(\zeta_r)_r \in \mathcal{A}_t^{\text{ex}}(\varphi)} \mathbb{E}[W_t], \quad (5.1)$$

where $\mathcal{A}_t^{\text{ex}}(\varphi)$ is the set of “real valued” progressively measurable processes $(\zeta_r)_r$ such that $\int_0^t \zeta_r dr \leq \varphi$. We note that this extended value function is not always derived from corresponding discrete time value functions, since our convergence theorem (Theorem 1) is based on the assumption that an execution strategy takes nonnegative values.

In fact, the assumption (4.2) is needed only to guarantee $p^*, \zeta_r^*, q^* > 0$ and the proof of Theorem 6 itself also works without (4.2). Let $(\hat{\zeta}_r^\delta)_r$ be given by (4.4) and let $(\hat{W}_r^\delta)_r$ be the corresponding process of the cash amount. The proof of Theorem 6 in Section 7.2 implies that

$$V_t^{\text{ex}}(w, \varphi, s; u_{\text{RN}}) \geq \lim_{\delta \rightarrow 0} \mathbb{E}[\hat{W}_t^\delta] = \limsup_{n \rightarrow \infty} V_{[nt]}^{n, \text{ex}}(w, \varphi, s; u_{\text{RN}}),$$

where $V_{[nt]}^{n, \text{ex}}(w, \varphi, s; u_{\text{RN}})$ is defined similarly to $V_t^{\text{ex}}(w, \varphi, s; u_{\text{RN}})$. Then we have the following.

Theorem 7. *Assume $z \geq 2y$. Then for each $\varphi \in \mathbb{R}$ the function $V_t^{\text{ex}}(w, \varphi, s; u_{\text{RN}})$ is not less than the right hand side of (4.5).*

We remark that the equation $H(\lambda) = 0$ has the unique solution

$$\lambda^* \in \left(0, \alpha e^{-y} P \left(\frac{\alpha \varphi - z}{\alpha(1 + \beta t)} \right) \right) \quad (5.2)$$

even if $\varphi \leq z/\alpha$. In this case p^*, ζ_r^* and q^* are not always positive.

As a special case of (5.1), we consider the value function $V_t^{\text{ex}}(0, 0, s; u_{\text{RN}})$. Following Huberman and Stanzl[9], we call an admissible strategy $(\zeta_r)_r \in \mathcal{A}_t^{\text{ex}}(0)$ a round trip and we define

a price manipulation strategy as a round trip such that the corresponding expected profit at the time horizon is positive. The following theorem indicates that we can construct a price manipulation strategy when the initial security price s is much larger than the fundamental value e^F .

Theorem 8. *For large enough z there is a price manipulation strategy.*

Proof. The equation $H(\lambda^*) = 0$ implies

$$\exp\left(\alpha\beta \int_0^t \xi_r^* dr\right) = e^{y-z}\lambda^*/\alpha.$$

Then, using Theorem 7 and the relations (5.2) and $\xi_r^* \leq 1/\alpha$, we get

$$\begin{aligned} V_t^{\text{ex}}(0, 0, s; u_{\text{RN}}) &\geq \lim_{\delta \rightarrow 0} \mathbb{E}[\hat{W}_t^\delta] \\ &= \frac{s}{\alpha} \left\{ 1 - (1 + \beta t)e^{y-z}\lambda^*/\alpha + \beta e^{y-z} \int_0^t \exp(e^{-2\beta r}y - \alpha\xi_r^*)dr \right\} > \frac{s}{\alpha}L(z), \end{aligned} \quad (5.3)$$

where

$$L(z) = 1 - (1 + \beta t + z) \exp\left(-\frac{\beta tz}{1 + \beta t}\right) + \beta te^{-z-1}.$$

Since $\lim_{z \rightarrow \infty} L(z) = 1$, the right hand side of (5.3) is not less than zero. Then we see that $(\hat{\zeta}_r^\delta)_r$ is a price manipulation strategy for small enough δ . \blacksquare

In a LOB model, the possibility of price manipulation is varied by small difference among the frameworks of the models. In Alfonsi and Schied[2], there is no price manipulation strategy in both linear and nonlinear MI and exponential resilience, but the result of Gatheral[6] asserts that price manipulation is possible under exponential resilience unless the MI function is linear. Theorem 8 implies the possibility of price manipulation in our framework, although the function (5.1) is only a formal generalization of our continuous time value function.

6 Concluding Remarks

In this paper we gave a tiny generalization of the results of Kato[11] and we solved the optimal execution problem in the case where a security price follows a geometric Ornstein Uhlenbeck process. This case is important in the sense that a security price has a mean reverting property. We showed that a (nearly) optimal strategy is the mixture of initial/terminal block liquidation and intermediate gradual liquidation when the initial amount of the security holdings is large. When the volatility is equal to zero, our result has the same form as the ones in Alfonsi et al.[1] and Obizhaeva and Wang[13]. In this case a trader should sell at the same speed until the time horizon. When the volatility is positive, the speed of gradual liquidation is not constant and the form of our optimal strategy is similar to the one in Makimoto and Sugihara[12].

Our example gives us a case where MI causes gradual liquidation. In the real market a trader sells his/her shares of a security gradually to avoid an MI cost because he/she expects

a recovery of the price. As noted in Section 1, examples in Kato[11] also suggest that strictly convex MI causes a gradual liquidation. Convexity (or nonlinearity) and a price recovery effect are both important factors in the construction of an MI model.

In Section 5, we considered the optimization problem when the trader is permitted to buy the security and we showed the possibility of price manipulation. It is important to construct a viable market model of execution, and it is intended, in future work, to find out conditions for the nonexistence of price manipulation. To make the arguments in Section 5 strict, we need to derive the corresponding convergence theorem such as Theorem 1 and this is another remaining task.

7 Appendix

7.1 Proof of Theorem 5

It is easy to see that $V_t(w, \varphi, s; u_{RN}) = w + e^{F+y}f(t)$ holds, where

$$\begin{aligned} f(t) &= \sup_{(\zeta_r)_r \in \mathcal{A}_t^{\det}(\varphi)} \tilde{f}((\zeta_r)_r), \\ \tilde{f}((\zeta_r)_r) &= \int_0^t \zeta_r \exp\left(e^{-\beta r} z - e^{-2\beta r} y - \alpha e^{-\beta r} \int_0^r e^{\beta v} \zeta_v dv\right) dr. \end{aligned} \quad (7.1)$$

So it suffices to consider the maximization problem (7.1).

By a straightforward calculation, we get

$$f(t) \geq \lim_{\delta \rightarrow 0} \tilde{f}((\hat{\zeta}_r^{I,\delta})_r) = \frac{1 - e^{-\alpha\varphi}}{\alpha} e^{z-y}.$$

Moreover, for any $(\zeta_r)_r \in \mathcal{A}_t^{\det}(\varphi)$ we have

$$\tilde{f}((\zeta_r)_r) \leq \int_0^t \zeta_r \exp\left(e^{-\beta r} z - e^{-2\beta r} y - \alpha e^{-\beta r} \eta_r\right) dr,$$

where $\eta_r = \int_0^r \zeta_v dv$. From the relation $z - 2y \geq \alpha\varphi \geq \alpha\eta_r$, we have

$$\begin{aligned} &\{z - y - \alpha\eta_r\} - \{e^{-\beta r} z - e^{-2\beta r} y - \alpha e^{-\beta r} \eta_r\} \\ &= (1 - e^{-\beta r})(z - (1 + e^{-\beta r})y - \alpha\eta_r) \geq 0. \end{aligned}$$

Thus

$$\tilde{f}((\zeta_r)_r) \leq \int_0^t \exp(z - y - \alpha\eta_r) d\eta_r \leq \frac{1 - e^{-\alpha\varphi}}{\alpha} e^{z-y}.$$

Then $f(t) \leq (1 - e^{-\alpha\varphi})e^{z-y}/\alpha$ and this completes the proof of Theorem 5.

7.2 Proof of Theorem 6

In this section we present the proof of Theorem 6. It follows the outline of Alfonsi et al. [1].

We fix w, φ, s for a while. For brevity we assume $t = 1$ until the end of this section. We define a function $f^n(n)$ by

$$f^n(n) = \frac{1}{\alpha} \sup_{(\psi_k^n)_k \in \mathcal{A}_n^{n, \text{det}}(\varphi)} \tilde{f}^n(\psi_0^n, \dots, \psi_{n-1}^n), \quad (7.2)$$

where $\mathcal{A}_k^{n, \text{det}}(\varphi)$ is the set of admissible strategies in $\mathcal{A}_k^n(\varphi)$ which are deterministic (we also define $\mathcal{A}_k^{n, \text{det}, \text{SO}}(\varphi)$ similarly),

$$\begin{aligned} & \tilde{f}^n(x) \\ &= \alpha \sum_{k=0}^{n-1} \exp \left(c_n^k z - c_n^{2k} y - \alpha \sum_{l=0}^{k-1} c_n^{k-l} x_l \right) \int_{k/n}^{(k+1)/n} n x_k \exp(-\alpha(nr - k)x_k) dr \\ &= \sum_{k=0}^{n-1} \exp \left(c_n^k z - c_n^{2k} y - \alpha \sum_{l=0}^{k-1} c_n^{k-l} x_l \right) (1 - e^{-\alpha x_k}), \quad x = (x_0, \dots, x_{n-1}) \in \mathbb{R}^n \end{aligned}$$

and $c_n = e^{-\beta/n}$. Since the function $\tilde{f}^n(x_0, \dots, x_{n-1})$ is nondecreasing in x_{n-1} , we can replace $\mathcal{A}_k^{n, \text{det}}(\varphi)$ in (7.2) with $\mathcal{A}_k^{n, \text{det}, \text{SO}}(\varphi)$. We have the following proposition.

Proposition 1. *It holds that $w + e^{F+y} f^n(n) \rightarrow V_1(w, \varphi, s; u)$ with $n \rightarrow \infty$.*

Proof. Let $\hat{f}^n(n) = e^{-F-y}(V_n^n(w, \varphi, s; u) - w)$. We easily have $\hat{f}^n(n) \leq f^n(n)$ and Theorem 1 implies $V_1(w, \varphi, s; u) \leq w + e^{F+y} \liminf_{n \rightarrow \infty} f^n(n)$. On the other hand, by the same arguments as in the proof of Proposition 2 of Kato[11], we can show the inequality $w + e^{F+y} \limsup_{n \rightarrow \infty} f^n(n) \leq V_1(w, \varphi, s; u)$. Then we have the assertion. \blacksquare

By the above proposition, we may solve the optimization problem $f^n(n)$ (and taking $n \rightarrow \infty$) instead of calculating $V_t(w, \varphi, s; u_{\text{RN}})$ (or $f(t)$) itself.

Let $\Xi^n(\varphi) = \{(x_0, \dots, x_{n-1}) \in \mathbb{R}^n; x_0 + \dots + x_{n-1} = \varphi\}$. We remark that $\mathcal{A}_k^{n, \text{det}, \text{SO}}(\varphi) \subset \Xi^n(\varphi)$. We set $\tilde{Q}_k^n(x) = \sum_{m=0}^l c_n^{l-m} x_m$ and $Q_l^n(x) = -z c_n^l + y c_n^{2l} + \alpha \tilde{Q}_k^n(x)$.

Lemma 3. *It holds that $\min_{k=0, \dots, n-1} Q_k^n(x) \rightarrow -\infty$ as $|x| \rightarrow \infty$ on $\Xi^n(\varphi)$.*

Proof. It suffices to show that $\min_{k=0, \dots, n-1} \tilde{Q}_k^n(x) \rightarrow -\infty$. Take any $M > 0$. Let $x \in \Xi^n(\varphi)$ be such that $\min_{k=0, \dots, n-1} \tilde{Q}_k^n(x) \geq -M$. Then we have

$$x_k + c_n x_{k-1} + \dots + c_n^k x_0 \geq -M, \quad k = 0, \dots, n-1. \quad (7.3)$$

Substituting the equality $x_{n-1} + \dots + x_0 = \varphi$ from (7.3) with $k = n-1$ and dividing by $1 - c_n$, we have

$$\sum_{k=0}^{n-2} \left(\sum_{l=0}^{n-2-k} c_n^l \right) x_k \leq \frac{M + \varphi}{1 - c_n}. \quad (7.4)$$

By (7.4) and (7.3) with $k = n - 2$, we have

$$\sum_{k=0}^{n-3} \left(\sum_{l=0}^{n-3-k} c_n^l \right) x_k \leq \left(\frac{1}{1-c_n} + 1 \right) (M + \varphi).$$

Calculating inductively, we get

$$\sum_{k=0}^{k'} \left(\sum_{l=0}^{k'-k} c_n^l \right) x_k \leq \left(\frac{1}{1-c_n} + n - 2 - k' \right) (M + \varphi) \leq a_n (M + \varphi) \quad (7.5)$$

for $k = 0, \dots, n - 2$, where $a_n = \{(1 - c_n)^{-1} + n\}$.

By (7.3) and (7.5) with $k = 0$, we have $-M \leq x_0 \leq a_n M$. Similarly, by (7.3) and (7.5) with $k = 1$, we have $-(1 + c_n C_{0,n})M \leq x_1 \leq (a_n + 1 + c_n)M$. By an inductive calculation we have $|x_k| \leq C_n(M + \varphi)$, $k = 0, \dots, n - 2$ and moreover the relation $x \in \Xi^n(\varphi)$ implies $|x_{n-1}| \leq C_n(M + \varphi)$ for some positive constant C_n .

The above arguments tell us that “if a sequence $(x^{(N)})_N \subset \Xi^n(\varphi)$ satisfies $\lim_{N \rightarrow \infty} \min_k \tilde{Q}_k^n(x^{(N)}) \neq -\infty$, then $(x^{(N)})_N$ is bounded,” which is the contrapositive of our assertion. ■

Lemma 4. *It holds that $\tilde{f}^n(x_0, \dots, x_{n-1}) \rightarrow -\infty$ as $|x| \rightarrow \infty$ on $\Xi^n(\varphi)$.*

Proof. Let $A_n(p) = e^{-c_n p + y} - e^{-p}$, $p \in \mathbb{R}$. Then we have

$$\begin{aligned} \tilde{f}^n(x) &= \sum_{k=0}^{n-1} (e^{-c_n Q_{k-1}^n(x) + y c_n^{2k-1}(1-c_n)} - e^{-Q_k^n(x)}) \\ &\leq e^{z-y} - e^{-Q_{n-1}^n(x)} + \sum_{k=0}^{n-2} A_n(Q_k^n(x)) \end{aligned}$$

for any $x = (x_0, \dots, x_{n-1}) \in \mathbb{R}^n$. We easily see that the function A_n has an upper bound $C_{A,n}$. Thus

$$\tilde{f}^n(x) \leq \begin{cases} e^{z-y} - \exp(-\min_k Q_k^n(x)) + C_{A,n} n, & \text{if } Q_{n-1}^n(x) = \min_k Q_k^n(x), \\ e^{z-y} + A_n(\min_k Q_k^n(x)) + C_{A,n}(n-1), & \text{otherwise.} \end{cases}$$

Since $\lim_{p \rightarrow -\infty} A_n(p) = -\infty$, we have the assertion by Lemma 3. ■

Lemma 5. *For each $k = 0, \dots, n - 2$, it holds that*

$$\begin{aligned} &\frac{\partial}{\partial x_k} \tilde{f}^n(x_0, \dots, x_{n-1}) \\ &= c_n \frac{\partial}{\partial x_{k+1}} \tilde{f}^n(x_0, \dots, x_{n-1}) + \alpha(1 - c_n) \exp(-c_n^{2k} y) F_k^n \left(\sum_{l=0}^k c_n^{k-l} x_l - c_n^k z / \alpha \right), \end{aligned}$$

where

$$F_k^n(x) = \frac{\exp(-\alpha x) - c_n \exp(-\alpha c_n x - c_n^{2k}(c_n^2 - 1)y)}{1 - c_n}.$$

Proof. For brevity, set $d_n^{(k)} = c_n^k z - c_n^{2k} y$. A straightforward calculation gives

$$\begin{aligned} \frac{\partial}{\partial x_k} \tilde{f}^n(x_0, \dots, x_{n-1}) &= \alpha \exp \left(d_n^{(k)} - \alpha \sum_{l=0}^k c_n^{k-l} x_l \right) \\ &\quad - \alpha \sum_{k'=k+1}^{n-1} c_n^{k'-k} \exp \left(d_n^{(k')} - \alpha \sum_{l=0}^{k'-1} c_n^{k'-l} x_l \right) (1 - e^{-\alpha x_{k'}}). \end{aligned} \quad (7.6)$$

Replacing k with $k+1$, we get

$$\begin{aligned} \frac{\partial}{\partial x_{k+1}} \tilde{f}^n(x_0, \dots, x_{n-1}) &= \alpha \exp \left(d_n^{(k+1)} - \alpha \sum_{l=0}^{k+1} c_n^{k+1-l} x_l \right) \\ &\quad - \alpha \sum_{k'=k+2}^{n-1} c_n^{k'-k-1} \exp \left(d_n^{(k')} - \alpha \sum_{l=0}^{k'-1} c_n^{k'-l} x_l \right) (1 - e^{-\alpha x_{k'}}) \\ &= -\frac{1}{c_n} \alpha \sum_{k'=k+1}^{n-1} c_n^{k'-k} \exp \left(d_n^{(k')} - \alpha \sum_{l=0}^{k'-1} c_n^{k'-l} x_l \right) (1 - e^{-\alpha x_{k'}}) \\ &\quad + \alpha \exp \left(d_n^{(k+1)} - \alpha \sum_{l=0}^k c_n^{k+1-l} x_l \right). \end{aligned} \quad (7.7)$$

By (7.6) and (7.7), we get the assertion. ■

We notice that F_k^n is nonincreasing on E_k^n and we can define the (nonincreasing) inverse function $F_k^{n,-1}$ on $[0, \infty)$, where

$$E_k^n = \left(-\infty, -\frac{1}{\alpha} \left(c_n^{2k} (c_n + 1) y + \frac{\log c_n}{1 - c_n} \right) \right].$$

Now we define the function $H_n(\lambda)$ by

$$H_n(\lambda) = \alpha \exp \left(\alpha (1 - c_n) \sum_{k=0}^{n-2} F_k^{n,-1}(\exp(c_n^{2k} y) \lambda / \alpha) - \alpha \varphi + z - c_n^{2(n-1)} y \right) - \lambda.$$

We consider the convergence of H_n . Let $\gamma_k^n(x)$, $R_k^n(x)$ and $G_k^n(x)$ be

$$\begin{aligned} \gamma_k^n(x) &= \alpha x + (1 + c_n) c_n^{2k} y, \\ R_k^n(x) &= \int_0^1 \exp(v(1 - c_n) \gamma_k^n(x)) (1 - v) dv (\gamma_k^n(x))^2, \\ G_k^n(x) &= \beta e^{-\alpha x} (\alpha x + (2 + c_n) c_n^{2k} y - c_n R_k^n(x)). \end{aligned}$$

Moreover we define

$$I(q) = \frac{d}{dq} P^{-1}(q) = \frac{\exp(\alpha P^{-1}(q))}{\alpha(\alpha P^{-1}(q) - 2)}$$

and $J_k^n(q) = -\exp(-2c_n^{2k} y) I(\exp(-2c_n^{2k} y) q) G_k^n(F_k^{n,-1}(q))$. Then we have the following.

Lemma 6. *It holds that*

$$\max_{k=0,\dots,n-1} \sup_{x \in E_k^n \cap K} |n(F_k^n(x) - P(x) + 2e^{-\alpha x} c_n^{2k} y) - G_k^n(x)| \longrightarrow 0, \quad n \rightarrow \infty$$

for each compact set $K \subset \mathbb{R}$.

Proof. For brevity we denote $\tilde{c}_n = 1 - c_n$. Using Taylor's theorem, we get

$$\begin{aligned} F_k^n(x) &= e^{-\alpha x} \left\{ 1 + \frac{c_n}{\tilde{c}_n} (1 - e^{\tilde{c}_n \gamma_k^n(x)}) \right\} \\ &= e^{-\alpha x} \{1 - c_n(\gamma_k^n(x) - \tilde{c}_n R_k^n(x))\} \\ &= P(x) - 2e^{-\alpha x} c_n^{2k} y + \tilde{c}_n G_k^n(x) / \beta. \end{aligned}$$

Thus it holds that

$$|n(F_k^n(x) - P(x) + 2e^{-\alpha x} c_n^{2k} y) - G_k^n(x)| \leq |n\tilde{c}_n/\beta - 1| \cdot |G_k^n(x)|.$$

Since we have $n\tilde{c}_n \longrightarrow \beta$ as $n \rightarrow \infty$ and

$$|G_k^n(x)| \leq 2\beta e^{2\alpha|x|+2y} (\alpha|x| + \alpha^2|x|^2 + 3y + 4y^2), \quad (7.8)$$

we obtain the assertion. ■

$$\text{Let } \varepsilon_k^n(q) = F_k^{n,-1}(q) - P^{-1}(\exp(-2c_n^{2k}y)q) + 2c_n^{2k}y/\alpha.$$

Lemma 7. *It holds that*

- (i) $\max_{k=0,\dots,n-1} \sup_{0 \leq q \leq M} |\varepsilon_k^n(q)| \longrightarrow 0,$
 - (ii) $\max_{k=0,\dots,n-1} \sup_{0 \leq q \leq M} |n\varepsilon_k^n(q) - J_k^n(q)| \longrightarrow 0$
- as $n \rightarrow \infty$ for each $M > 0$.

Proof. The assertion (i) is a direct consequence of the assertion (ii), so we will prove only (ii). Take any $q \in [0, M]$ and let $x_k^n = F_k^{n,-1}(q)$. Since $F_k^n(x)$ is nondecreasing with respect to n and k for each fixed x , we get $x_k^n \in K_M$ for any n and k , where

$$K_M = \left[F_0^{1,-1}(M), \frac{\beta}{\alpha(1 - e^{-\beta})} \right].$$

Let $\tilde{R}_k^n(x) = F_k^n(x) - P(x) + 2e^{-\alpha x} c_n^{2k} y$. By the relation

$$P(x_k^n) - 2e^{-\alpha x_k^n} c_n^{2k} y + \tilde{R}_k^n(x_k^n) = q,$$

we get

$$P(x_k^n + 2c_n^{2k}y/\alpha) = \exp(-2c_n^{2k}y)(q - \tilde{R}_k^n(x_k^n)).$$

Since Lemma 6 implies

$$\max_{k=0,\dots,n-1} \sup_{x \in K_M \cap E_k^n} |\tilde{R}_k^n(x)| \longrightarrow 0, \quad n \rightarrow \infty, \quad (7.9)$$

we see that $\exp(-2c_n^{2k}y)(q - \tilde{R}_k^n(x_k^n)) > -e^{-3/2}/2 > -e^{-2}$ for large enough n and $k = 0, \dots, n-1$, and we get

$$\begin{aligned} & x_k^n - P^{-1}(\exp(-2c_n^{2k}y)q) + 2c_n^{2k}y/\alpha \\ &= P^{-1}(\exp(-2c_n^{2k}y)q) - P^{-1}(\exp(-2c_n^{2k}y)(q - \tilde{R}_k^n(x_k^n))). \end{aligned}$$

Since it follows that

$$-2e^{3/2}/\alpha \leq I(q) < 0 < \frac{d}{dq}I(q) \leq 12e^3/\alpha$$

for each $x \geq -e^{-3/2}/2$, we have

$$\begin{aligned} & |n(x_k^n - P^{-1}(\exp(-2c_n^{2k}y)q) + 2c_n^{2k}y/\alpha) - J_k^n(q)| \\ &\leq \left| \int_0^1 I(\exp(-2c_n^{2k}y/\alpha)(q - v\tilde{R}_k^n(x_k^n)))dv n\tilde{R}_k^n(x_k^n) - I(\exp(-2c_n^{2k}y)q)G_k^n(x_k^n) \right| \\ &\leq \frac{2e^{3/2}}{\alpha} |n\tilde{R}_k^n(x_k^n) - G_k^n(x_k^n)| + \frac{12e^3}{\alpha} |\tilde{R}_k^n(x_k^n)| \cdot |G_k^n(x_k^n)|. \end{aligned}$$

By Lemma 6, (7.8), and (7.9), we obtain the assertion (ii). ■

By Lemma 7, we get the following proposition.

Proposition 2. H_n converges to H uniformly on any compact set in \mathbb{R} .

By Proposition 2 and the fact that H_n is strictly decreasing on $[0, \infty)$, we can take n large enough so that there is a unique solution $\hat{\lambda}^n$ of $H_n(\lambda) = 0$ on $(0, 2\lambda^*)$. Moreover it follows that $\hat{\lambda}^n$ converges to λ^* as $n \rightarrow \infty$.

We set $\hat{\psi}_k^n = \mathcal{T}_k(\hat{\lambda}^n)$, $k = 0, \dots, n-1$, where

$$\begin{aligned} \mathcal{T}_0(\lambda) &= F_0^{n,-1}(\exp(y)\lambda/\alpha) + z/\alpha, \\ \mathcal{T}_k(\lambda) &= F_k^{n,-1}(\exp(c_n^{2k}y)\lambda/\alpha) - c_n F_{k-1}^{n,-1}(\exp(c_n^{2(k-1)}y)\lambda/\alpha), \quad k = 1, \dots, n-2, \\ \mathcal{T}_{n-1}(\lambda) &= \varphi - (1 - c_n) \sum_{k=0}^{n-3} F_k^{n,-1}(\exp(c_n^{2k}y)\lambda/\alpha) \\ &\quad - F_{n-2}^{n,-1}(\exp(c_n^{2(n-2)}y)\lambda/\alpha) - z/\alpha. \end{aligned}$$

Lemma 8. It holds that $|\hat{\psi}_0^n - p^*| + \max_{k=1, \dots, n-2} |n\hat{\psi}_k^n - \zeta_{k/n}^*| + |\hat{\psi}_{n-1}^n - q^*| \rightarrow 0$ as $n \rightarrow \infty$.

Proof. By Lemma 7, we have

$$\begin{aligned} & |\hat{\psi}_0^n - p^*| + \max_{k=1, \dots, n-2} |n\hat{\psi}_k^n - \zeta_{k/n}^*| + |\hat{\psi}_{n-1}^n - q^*| \\ &\leq C \left\{ |n(1 - c_n) - \beta| + \varepsilon_n + \tilde{\varepsilon}_n \right. \\ &\quad \left. + \max_{k=0, \dots, n-1} \left| J\left(\frac{k}{n}, \exp(c_n^{2k}y)\hat{\lambda}^n/\alpha\right) - J\left(\frac{k-1}{n}, \exp(c_n^{2(k-1)}y)\hat{\lambda}^n/\alpha\right) \right| \right\} \end{aligned}$$

for some positive constant C depending only on α, β, y , and z , where

$$\begin{aligned} J(r, q) &= \exp(-2e^{-\beta r}y)I(\exp(-2e^{-\beta r}y)q)G(r, \tilde{F}(r, q)), \\ G(r, x) &= \beta e^{-\alpha x}(\alpha x + 3e^{-2\beta r}y - (\alpha x + 2e^{-2\beta r}y)^2/2), \\ \tilde{F}(r, q) &= P^{-1}(\exp(-e^{-2\beta r}y)q) - 2e^{-2\beta r}y/\alpha \end{aligned}$$

and ε_n (respectively, $\tilde{\varepsilon}_n$) is the left hand side of Lemma 7(i) (respectively, (ii).) Since J is continuous on $[0, 1] \times [0, \infty)$, we get the assertion. \blacksquare

Lemma 8 and the relations $p^*, \zeta_r^*, q^* > 0$ imply the following lemma.

Lemma 9. *It holds that $\hat{\psi}_k^n > 0$, $k = 0, \dots, n-1$ for large enough n .*

Now we define an $(n+1)$ -variable function $\mathcal{L}_n(x_0, \dots, x_{n-1}, \lambda)$ by

$$\mathcal{L}_n(x_0, \dots, x_{n-1}, \lambda) = \tilde{f}^n(x_0, \dots, x_{n-1}) + \lambda(\varphi - x_0 - \dots - x_{n-1}).$$

Then we have the following.

Lemma 10. *When n is large enough, the vector $(\hat{\psi}_0^n, \dots, \hat{\psi}_{n-1}^n, \hat{\lambda}^n)$ is the unique solution of*

$$\frac{\partial}{\partial x_0} \mathcal{L}_n = \dots = \frac{\partial}{\partial x_{n-1}} \mathcal{L}_n = \frac{\partial}{\partial \lambda} \mathcal{L}_n = 0. \quad (7.10)$$

Proof. Suppose that a vector $(\tilde{x}_0, \dots, \tilde{x}_{n-1}, \tilde{\lambda})$ is a solution of (7.10). Then we have $\tilde{x}_0 + \dots + \tilde{x}_{n-1} = \varphi$ and Lemma 5 implies

$$\tilde{\lambda} = c_n \tilde{\lambda} + \alpha(1 - c_n) \exp(-c_n^{2k}y) F_k^n \left(\sum_{l=0}^k c_n^{k-l} \tilde{x}_l - c_n^k z / \alpha \right),$$

thus

$$\sum_{l=0}^k c_n^{k-l} \tilde{x}_l = F_k^{n,-1}(\exp(c_n^{2k}y) \tilde{\lambda} / \alpha) + c_n^k z / \alpha, \quad k = 0, \dots, n-2. \quad (7.11)$$

Then we see that $\tilde{x}_k = \mathcal{T}_k(\tilde{\lambda})$, $k = 0, \dots, n-1$. Then we have

$$\begin{aligned} 0 &= \frac{\partial}{\partial x_{n-1}} \mathcal{L}_n(\tilde{x}_0, \dots, \tilde{x}_n, \tilde{\lambda}) \\ &= \alpha \exp \left(c_n^{n-1} z - c_n^{2(n-1)} y - \alpha \sum_{l=0}^{n-1} c_n^{n-1-l} \tilde{x}_l \right) - \tilde{\lambda} = H_n(\tilde{\lambda}). \end{aligned}$$

Since $\hat{\lambda}^n$ is the unique solution of $H_n(\lambda) = 0$, we have $\tilde{\lambda} = \hat{\lambda}^n$. This equality also implies $\tilde{x}_k = \mathcal{T}_k(\hat{\lambda}^n) = \hat{\psi}_k^n$, $k = 0, \dots, n-1$. Thus the solution of (7.10) is unique. The above arguments also tell us that $(\hat{\psi}_0^n, \dots, \hat{\psi}_{n-1}^n, \hat{\lambda}^n)$ satisfies (7.10). \blacksquare

Now we have the following proposition.

Proposition 3. *It holds that $f^n(n) = \tilde{f}^n(\hat{\psi}_0^n, \dots, \hat{\psi}_{n-1}^n)/\alpha$ for enough large n .*

Proof. By Lemma 4, we can find $M > 0$ large enough so that $\tilde{f}^n(x) < 0$ holds for $x \in \Xi^n(\varphi)$ with $|x| \geq M$. Then \tilde{f}^n has at least one local maximum point on $(-M, M)^n$ ($\tilde{x} = (\tilde{x}_0, \dots, \tilde{x}_{n-1})$, say.) By the Lagrange multiplier method, we see that there is some $\tilde{\lambda} \in \mathbb{R}$ such that (7.10) holds at $(\tilde{x}, \tilde{\lambda})$. Then Lemma 10 implies $\tilde{x}_k = \hat{\psi}_k^n$ for $k = 0, \dots, n-1$. This means that $(\hat{\psi}_1, \dots, \hat{\psi}_{n-1})$ is the unique local maximum, which is inevitably the global maximum of \tilde{f}^n on $\Xi^n(\varphi)$. \blacksquare

Now we prove Theorem 6. We divide $\tilde{f}^n(\hat{\psi}_0^n, \dots, \hat{\psi}_{n-1}^n)$ into the following three parts:

$$\begin{aligned} \tilde{f}^n(\hat{\psi}_0^n, \dots, \hat{\psi}_{n-1}^n) &= e^{z-y}(1 - e^{-\alpha\hat{\psi}_0^n}) \\ &\quad + \sum_{k=1}^{n-2} \exp\left(c_n^k z - c_n^{2k} y - \alpha \sum_{l=0}^{k-1} c_n^{k-l} \hat{\psi}_l^n\right) (1 - e^{-\alpha\hat{\psi}_k^n}) \\ &\quad + \exp\left(c_n^{n-1} z - c_n^{2(n-1)} y - \alpha \sum_{k=0}^{n-2} c_n^{n-1-k} \hat{\psi}_k^n\right) (1 - e^{-\alpha\hat{\psi}_{n-1}^n}) \\ &= \tilde{A}_n + \tilde{B}_n + \tilde{C}_n. \end{aligned}$$

By Lemma 8, we easily get

$$\tilde{A}_n \longrightarrow e^{z-y}(1 - e^{-\alpha p^*}), \quad n \rightarrow \infty. \quad (7.12)$$

Using the relation (7.11) and Lemmas 7–8, we have

$$\begin{aligned} \tilde{C}_n &= \exp\left((c_n^{n-1} - c_n^{n-2})z - c_n^{2(n-1)}y - \alpha F_{n-2}^{n,-1}(\exp(c_n^{2(n-1)}y)\hat{\lambda}^n/\alpha)\right) \\ &\quad \times (1 - e^{-\alpha\hat{\psi}_{n-1}^n}) \\ &\longrightarrow \exp\left(e^{-2\beta}y - \alpha P^{-1}(\exp(e^{-2\beta}y)\lambda^*/\alpha)\right) (1 - e^{-\alpha q^*}) \\ &= e^{z-y} e^{-\alpha \eta_1^*} (1 - e^{-\alpha q^*}). \end{aligned} \quad (7.13)$$

To calculate the limit of \tilde{B}_n we set

$$\hat{B}_n = \frac{\alpha}{n} \sum_{k=1}^{n-2} \exp(c_n^{2k} y - \alpha \zeta_{k/n}^*) \zeta_{k/n}^*.$$

Then we have

$$\begin{aligned} |\tilde{B}_n - \hat{B}_n| &\leq e^z \left\{ \sum_{k=1}^{n-2} \left| e^{-\alpha\hat{\psi}_k^n} - e^{-\alpha\zeta_{k/n}^*} \right| + \sum_{k=1}^{n-2} \left| 1 - e^{-\alpha\zeta_{k/n}^*} - \frac{\alpha\zeta_{k/n}^*}{n} \right| \right\} \\ &\quad + \frac{\alpha}{n} \sum_{k=1}^{n-2} \left| \exp(-c_n^{2k} y - \alpha F_k^{n,-1}(\exp(c_n^{2k} y)\hat{\lambda}^n/\alpha)) - \exp(c_n^{2k} y - \alpha \zeta_{k/n}^*) \right| \zeta_{k/n}^* \\ &\longrightarrow 0, \quad n \rightarrow \infty \end{aligned} \quad (7.14)$$

by virtue of (7.11) and Lemmas 7–8. Moreover we have

$$\begin{aligned}\lim_{n \rightarrow \infty} \hat{B}_n &= \alpha \int_0^1 \exp(e^{-2\beta r} y - \alpha \xi_r^*) \zeta_r^* dr = \alpha e^{z-y} \int_0^1 e^{-\alpha \eta_r^*} \left(\beta \xi_r^* + \frac{d}{dr} \eta_r^* \right) dr \\ &= \alpha \beta e^{z-y} \int_0^1 e^{-\alpha \eta_r^*} \xi_r^* dr + e^{z-y} (e^{-\alpha p^*} - e^{-\alpha \eta_1^*}).\end{aligned}\tag{7.15}$$

By (7.12)–(7.15), we see that $w + e^{F+y}(\tilde{A}_n + \tilde{B}_n + \tilde{C}_n)$ converges to the right hand side of (4.5). Then we obtain the assertion by Proposition 1.

References

- [1] A. ALFONSI, A. FRUTH AND A. SCHIED, *Optimal execution strategies in limit order books with general shape functions*, Quant. Finance, 10(2010), pp. 143–157.
- [2] A. ALFONSI AND A. SCHIED, *Optimal trade execution and absence of price manipulations in limit order book models*, SSRN Paper http://papers.ssrn.com/sol3/papers.cfm?abstract_id=1499209, 2010.
- [3] A. ALFONSI, A. SCHIED AND A. SLYNKO, *Order book resilience, price manipulation, and the positive portfolio problem*, SSRN Paper http://papers.ssrn.com/sol3/papers.cfm?abstract_id=1498514, 2011
- [4] R. ALMGREN AND N. CHRISS, *Optimal execution of portfolio transactions*, J. Risk, 3(2000), pp. 5–39.
- [5] BERTSIMAS, D. AND A.W. LO, *Optimal control of execution costs*, J. Fin. Markets, 1(1998), pp. 1–50.
- [6] J. GATHERAL, *No-dynamic-arbitrage and market impact*, Quant. Finance, 10(2010), pp. 749–759.
- [7] J. GATHERAL, A. SCHIED AND A. SLYNKO, *Exponential resilience and decay of market impact*, In: Abergel, F., Chakrabarti, B.K., Chakraborti, A., Mitra, M., (eds.): *Econophysics of Order-driven Markets*, Proceedings of Econophys-Kolkata V., pp. 225–236. Springer, Berlin, 2011.
- [8] H. HE AND H. MAMAYSKY, *Dynamic trading policies with price impact*, J. Econ. Dynamics and Control, 29(2005), pp. 891–930.
- [9] G. HUBERMAN AND W. STANZL, *Price manipulation and quasi-arbitrage*, Econometrica, 74-4(2004), pp. 1247–1276.
- [10] G. HUBERMAN AND W. STANZL, *Optimal liquidity trading*, Review of Finance, 9-2(2005), pp. 165–200.
- [11] T. KATO, *Optimal execution problem with market impact*, arXiv Preprint <http://arxiv.org/pdf/0907.3282>, 2009.

- [12] N. MAKIMOTO AND Y. SUGIHARA, *Optimal execution of multiasset block orders under stochastic liquidity*, IMES Discussion Paper Series <http://www.imes.boj.or.jp/research/papers/english/10-E-25.pdf>, 2010.
- [13] A. OBIZHAEVA AND J. WANG, *Optimal trading strategy and supply/demand dynamics*, EFA 2005 Moscow Meetings Paper.
- [14] S. PREDOIU, G. SHAIKHET AND S. SHREVE, *Optimal execution in a general one-sided limit-order book*, SIAM J. Financial Math., 2(2011), pp. 183–212.
- [15] A. SCHIED AND T. SCHÖNEBORN, *Risk aversion and the dynamics of optimal liquidation strategies in illiquid markets*, Finance Stoch., 13-2(2008), pp. 181–204.
- [16] A. SUBRAMANIAN AND R. JARROW, *The liquidity discount*, Math. Finance, 11(2001), pp. 447–474.

UTMS

- 2011–13 Shigeo Kusuoka and Takenobu Nakashima: *A remark on credit risk models and copula.*
- 2011–14 Tomohiko Ishida and Nariya Kawazumi: *The Lie algebra of rooted planar trees.*
- 2011–15 Yusaku Tiba: *Kobayashi hyperbolic imbeddings into toric varieties.*
- 2011–16 Yuko Hatano, Junichi Nakagawa, Shengzhang Wang and Masahiro Yamamoto: *Determination of order in fractional diffusion equation.*
- 2011–17 Takashi Tsuboi: *Homeomorphism groups of commutator width one.*
- 2011–18 J. Noguchi: *Another direct proof of Oka's theorem (Oka IX).*
- 2011–19 M. Abe, S. Hamano and J. Noguchi: *On Oka's extra-zero problem.*
- 2011–20 Oleg Yu. Imanuvilov and Masahiro Yamamoto : *On reconstruction of Lamé coefficients from partial Cauchy data.*
- 2011–21 Pen-Yuan Hsu, Yasunori Maekawa: *On nonexistence for stationary solutions to the Navier-Stokes equations with a linear strain.*
- 2011–22 Hitoshi Kitada: *Timeless system, superluminal phenomena, dark matter and Big Bang.*
- 2011–23 Takashi Kato: *An optimal execution problem with market impact.*
- 2011–24 Takashi Kato: *An optimal execution problem in geometric Ornstein Uhlenbeck price process.*

The Graduate School of Mathematical Sciences was established in the University of Tokyo in April, 1992. Formerly there were two departments of mathematics in the University of Tokyo: one in the Faculty of Science and the other in the College of Arts and Sciences. All faculty members of these two departments have moved to the new graduate school, as well as several members of the Department of Pure and Applied Sciences in the College of Arts and Sciences. In January, 1993, the preprint series of the former two departments of mathematics were unified as the Preprint Series of the Graduate School of Mathematical Sciences, The University of Tokyo. For the information about the preprint series, please write to the preprint series office.

ADDRESS:

Graduate School of Mathematical Sciences, The University of Tokyo
3–8–1 Komaba Meguro-ku, Tokyo 153-8914, JAPAN
TEL +81-3-5465-7001 FAX +81-3-5465-7012